



Grundfos Innovation

Lab test evaluation of a dynamic sewer control solution

Testing dynamic sewer control on a scaled-down wastewater network

To validate our dynamic sewer control solution, we constructed a scaled-down wastewater network. This setup allowed us to replicate identical rain events under varying configurations and conditions, providing robust, side-by-side performance insights and evaluations of our solution. In this paper, we outline its core technology and present key results from our controlled tests.

Dynamic Sewer Control

Copyright © Grundfos Holding A/S 2025

Authors and contributors:

Chengzi Chew (Project Lead) | MSc Hydroinformatics and Water Management

Rebekka Høy Biegel | MSc Information Studies

Rachel Sandrina Rissa | MSc Product Development and Innovation

Carsten Skovmose Kallesøe | PhD, MSc Control & Automation Engineering

Ørjan Heggdal | MSc Water and Environmental Engineering

Krisztian Mark Balla | Industrial PhD, MSc Control & Automation Engineering

Mads Veje Knudsen

Kristian Lydersen Rindom

RTC4Water

Alex Cornelissen | PhD in Analytical and Environmental Chemistry, MSc Chemistry

Georges Schutz | PhD in Informatics, Dipl. -Ing. Mechanics

Table of Contents

Executive Summary	3
Introduction	4
Dynamic Control of Wastewater Networks	5
Glossary	5
Control approaches: static and dynamic control	5
Operation of dynamic control	6
Achieving Efficient Infrastructure Utilization	8
Dynamic Control in Operational Practice	9
Technology enabling dynamic control	9
Robustness and Resilience in Dynamic Control	11
Standardized communication through OPC-UA	11
Connectivity and control communication	11
Control hierarchy and control modes	11
Hydraulic and Operational Performance Tests	16
Introduction	16
Hydraulic performance	17
Operational performance	17
Test setup	17
Hydraulic performance of dynamic control	18
Scenario 1 Baseline scenario with three consecutive rain events	19
Scenario 2 Increased travel time between tanks 2 and 3	22
Scenario 3 Changed catchment properties with better control opportunities	25
Scenario 4 Differentiated sensitivity in receiving water bodies	28
Conclusion	29
Operational performance of software integration	30
Network disconnection (short)	31
Network disconnection (long)	34
Sensor failure (flow sensor malfunction)	37
Conclusion	40

Executive Summary

Wastewater utilities face growing challenges from aging infrastructure, made worse by population growth, urbanization and the effects of climate change. Many sewage networks cannot keep pace with the additional volume and load, leading to overflow events polluting receiving water bodies. Effectively operating and maintaining these sewage systems has become difficult with limited operational flexibility and storage capacity. Traditionally, utilities have relied on building additional storage or separating sewers to address these issues, but such upgrades are costly and time-consuming.

This Grundfos innovation offers a smarter option. Rather than solely relying on expanding physical infrastructure, our control approach reduces operational complexity through real-time system monitoring, flow forecasts and autonomous adjustments to assets like pumps, valves and storage tanks. This approach is known as **dynamic control**. By optimizing the performance of existing assets and increasing operational flexibility, sewer capacity can be used efficiently, minimizing overflows and protect receiving waters—all while maintaining operational safety and resilience

To verify the effectiveness of this technology, we have rigorously tested the solution in laboratory conditions using a scaled-down wastewater network with three Combined Sewer Overflow (CSO) tanks. The objective was to verify whether dynamic, real-time control could deliver measurable benefits under realistic conditions and operational challenges. The testing included verifying for optimized hydraulic performance, as well as operational performance to ensure solution resilience.

Key benefits demonstrated include:

- Real-time rain response, freeing up capacity between rain events,
- Autonomous network management, reducing manual intervention and improving resilience,
- Compatibility with existing systems through SCADA/PLC integration with OPC-UA,

- Built-in fallback strategies, ensuring safe and predictable operation during communication or sensor failures,
- Hands-off operation that monitors and controls without operator input.

Hydraulic Performance:

- Scenario 1: Baseline performance comparison
35% overflow reduction
- Scenario 2: Increased travel time between pumping stations
28% overflow reduction
- Scenario 3: Changed catchment properties with better control opportunities
69% overflow reduction
- Scenario 4: Differentiated sensitivity in receiving water bodies
Ability to prioritize overflow reduction at sensitive locations

Operational Performance:

- Operations with short IT-network disconnection
Maintains effective storage management
- Operations with long IT-network disconnection
Demonstrates robust fallback mechanisms
- Sensor failure test
System remains stable and recovers seamlessly

In conclusion, the tests confirm that dynamic, real-time control through Grundfos' control solution can significantly reduce overflows and enhance operational robustness. While performance depends on factors such as available capacity and network structure and flexibility, these results demonstrate that utilities can achieve substantial improvements without major infrastructure investments.

Throughout this document, Grundfos' control solution is referred to as **Dynamic Sewer Control (DSC)**.

Introduction

Wastewater utilities face growing pressure from urbanization and changing rainfall patterns. Many sewer networks—originally engineered for a different climate, sewage and rain loads—now experience frequent Combined Sewer Overflow (CSO) events and quality impacts in receiving water bodies. Traditional remediation focuses on civil upgrades, like bigger pipes and tanks, which are capital-intensive and slow to implement.

Grundfos offers another option: a dynamic, data-driven approach to optimize existing assets (pumps, valves, storage) so networks make better use of the capacity they already have. Again, we'll refer to it hereafter as our **Dynamic Sewer Control (DSC) solution**.

At Grundfos, we have tested this solution rigorously. This paper demonstrates DSC's ability to optimize utilization of existing capacity, as well as its resilience in suboptimal operating conditions.

We evaluated whether the DSC can:

1. **Perform dynamic control** that actively optimizes available storage across a network during rain events,
2. **Forecast and utilize travel times** between assets to anticipate peaks and shift volumes,
3. **Remain robust in suboptimal operational conditions** e.g. network/SCADA interruptions, maintenance states and sensor failures,
4. **Provide effective fallbacks** in conditions where communication is degraded or local measurements fail, ensuring that structures continue operating in safe, predictable modes and maintain network stability.

In the following section, we introduce the technology involved in the DSC, as well as provide context on the control strategy utilized to achieve efficient and resilient management of wastewater infrastructure.



Dynamic Control of Wastewater Networks

Glossary

System: The entire sewer network, including pumping stations, storage tanks, pressure and gravity pipes and the wastewater treatment plant (WWTP) inlet, along with the automation infrastructure (Sensors, Programmable Logic Controllers (PLCs) and Supervisory Control and Data Acquisition (SCADA) Systems).

Asset or Component: Any controllable or measurable element within the system, such as storage units (tanks or big pipes), pumps, valves, sensors or local controllers.

Static Control: A control strategy where each component operates based on fixed, predefined setpoints without considering the overall system state.

Dynamic Control: A real-time, adaptive strategy that uses system-wide data and predictive algorithms to optimize performance across multiple assets.

Control Mode: The operational state of a component or station, such as manual, auto-local, controllable or controlled.

Fallback: A predefined, safe operating behavior that ensures stability when communication or sensor data is lost.

Control approaches: static and dynamic control

Static control is the traditional approach in sewer networks and remains most frequently found in sewer networks today. Each pumping station operates independently based on local measurements, typically using simple on/off logic or fixed level setpoints. While practical to implement, the static control approach cannot easily adapt to changing conditions across the network. For example, a pump may start when its wet-well reaches a certain level, regardless of whether downstream capacity is available.

Dynamic control uses measurements from multiple points in the network to co-ordinate actions across

assets and operate as a collective. The system anticipates inflows, travel times and downstream availability, adjusting pump speeds or valve positions to minimize overflows and optimize storage utilization. This approach transforms the network from a collection of isolated units into an integrated, adaptive system.

The two control approaches can be compared as follows: the dynamic control approach operates the system as a co-operative collection of assets, while the static control approach can be likened to a collection of individually acting assets. It is important to mention that the implementation of a static control approach can be optimal for the network it was configured for. However, wastewater infrastructures are rarely revised or upgraded to match the continuously evolving area it serves. The static control approach has no way to adapt without manual intervention, whereas dynamic control adapts to any change the system experiences.

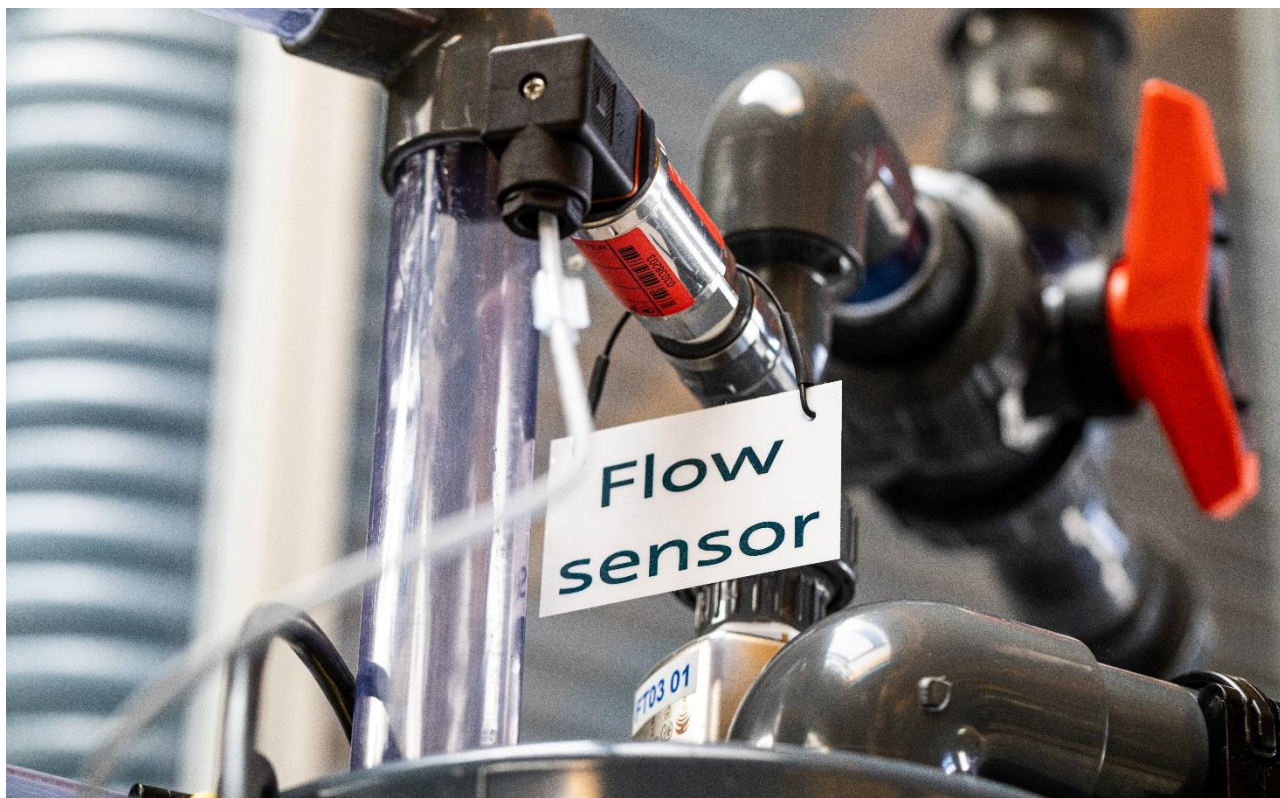

Operation of dynamic control

Dynamic control of a system operates through the following control approach:

Real-time monitoring: Co-operation of the assets is possible through sensors that continuously collect measurements of key parameters such as water levels, flows and sometimes rainfall data. These measurements are traditionally just sent to a SCADA to be visualized, but in dynamic control they are analyzed by a **controller**—our DSC solution in this case—for optimization.

Optimization and predictive forecasting: The controller uses the measured real-time data, past data, as well as a hydraulic model to forecast future states (e.g. tank filling levels, overflow risks). Thereafter, it computes optimal setpoints for pumps and valves to obtain the most advantageous future state.

Execution: The DSC sends instructions to the relevant local PLCs, which are then implemented by adjusting the pumps and valves.

Communication between local controllers/SCADA and the DSC is standardized through ISO-standard OPC Unified Architecture (OPC-UA). This ensures that variables are efficiently managed.

This communication setup between devices allows a hierarchical structure, enabling system-wide optimization while also ensuring that changes are applied securely and that local safety interlocks and protocols remain active. Communication of assets and operational security are detailed in a further section.

Static systems - How the hardware is connected

1

Measurements like volume and pump status is retrieved by the PLC.

2

Information from the PLC is sent to the central SCADA system for visualization.

3

The information becomes available to the user through their SCADA software, providing limited overview about their system.

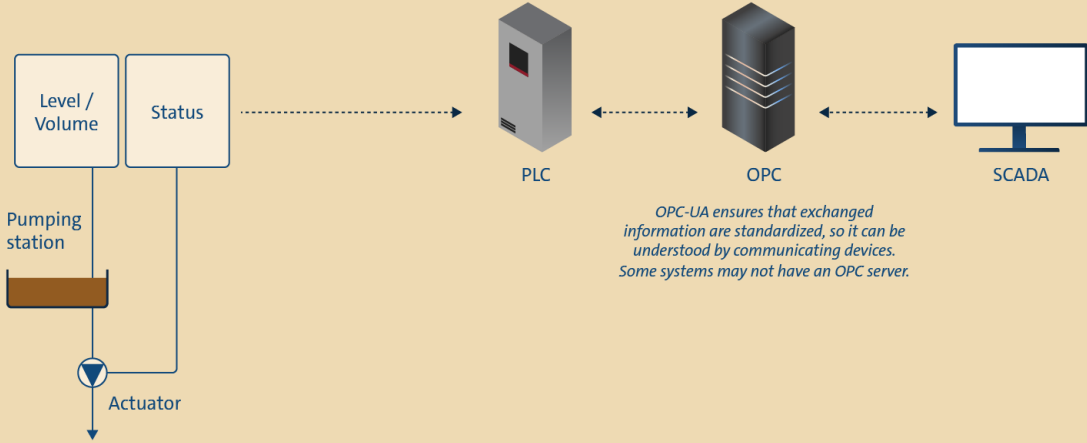

Dynamic systems - How the hardware is connected

1

Measurements like volume, pump status and flow is retrieved by the PLC.

2

Information from the PLC is sent to the central SCADA system for visualization.

3

The DSC provides comprehensive information of the system, and if needed, enables remote setting of flow setpoints.

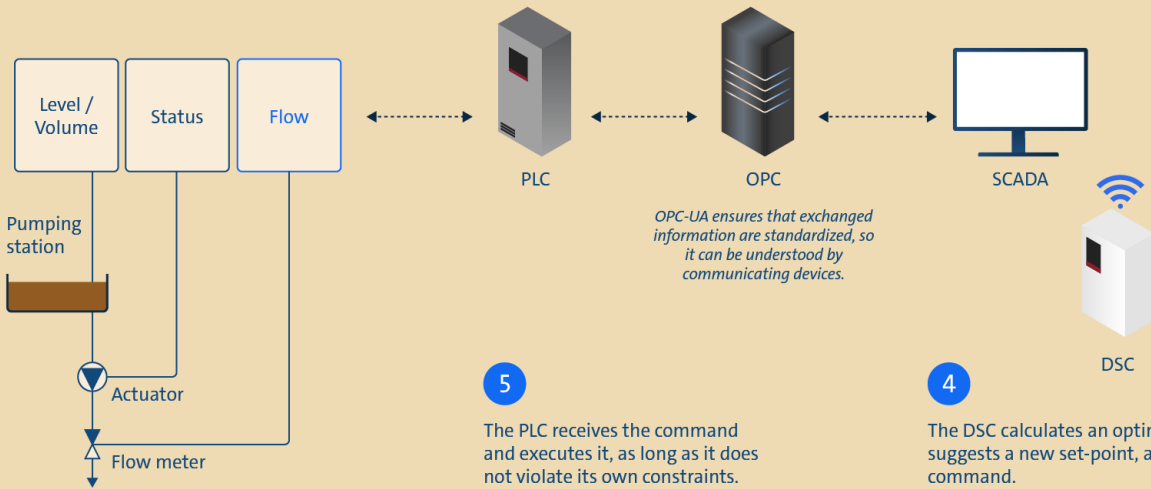

Achieving Efficient Infrastructure Utilization

How can overflow minimization be achieved through a dynamic control strategy, without physical expansion of the infrastructure to contain more volume? The answer lies in how dynamic control homogeneously distributes volume throughout the sewer infrastructure in proportion to the local capacities. The nature of static or rule-based operation of assets means that volume will be moved to the treatment plant when local conditions allow. Consequently, wastewater is moved even if there is no downstream capacity or when there is still potential to further utilize local remaining storage.

Dynamic control makes efficient use of the infrastructure by utilizing capacity that is otherwise unused with static control. Additionally, it considers not only individual pumping stations but every capacity it is connected to. This is possible due to the way assets are controlled. In dynamic control, the control of assets is automatically adjusted in conjunction with other assets. This means that assets

can, for example, move water pre-emptively if capacity downstream allows for it, slow down outflow if a station ahead is experiencing large inflow from heavy rain, etc.

This co-operation means that wastewater can be efficiently distributed throughout the system. In other words, the dynamic controller strives for **proportional homogeneity** of storage capacity. Doing so minimizes overflow in places where static control would have otherwise caused an imbalance in distributed water.

With the DSC, it is also possible to prioritize certain pumping stations to avoid overflows. This is particularly useful in areas with sensitive ecosystems or to avoid nuisances.

Finally, with efficient utilization of existing infrastructure, it becomes possible to clearly identify where infrastructure upgrades are most needed, resulting in much more informed investment decisions. Example scenarios are provided in this paper, which can be found in later sections.



Utilizing the entire system's potential

The DSC utilizes the system by considering capacity potential of storage components that goes unused with static control, whether it's a CSO tank, basin, pipes, or any other part of the infrastructure that can hold water.

The optimization potential is directly related to the total potential storage capacity available within the system.

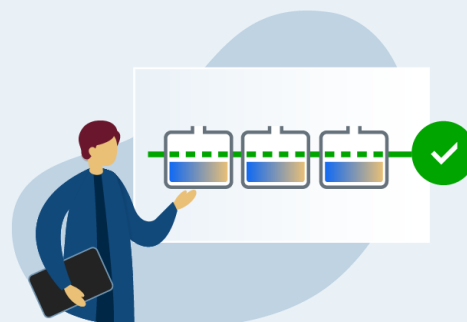

Towards homogeneity

Striving to approach homogeneity ensures that the system's storage is evenly distributed.

The DSC dynamically optimizes capacity use by retaining water where there is unused space, thereby freeing up capacity for places where it is needed more. This approach maximizes utility of storage capacity.

Dynamic Control in Operational Practice

Technology enabling dynamic control

As discussed previously, dynamic control is achievable through real-time monitoring, predictive modelling and standardized communication between assets. Implementation requires that the sewer system is technologically ready for dynamic control. With the DSC, this is typically achieved by only upgrading the assets that are needed for control, after an assessment of the wastewater infrastructure and discussions with the system operational staff and management.

Grundfos will assist with the preparation and installation of any additional required assets, if it is needed.

The following is an example of how Grundfos prepares a sewer network to be technologically ready for dynamic control. In the following illustration, a simple sewer infrastructure possesses commonly found assets and employs static control.

The following is a list of requirements a sewer network needs to fulfil, to implement a dynamic control solution like a DSC.

1. **Level sensors** in tanks and wet wells and **flow measurement** (or reliable estimation) at strategic points,
2. **A SCADA system** for real-time data exchange among field devices and the supervisory controller,
3. **Controllable assets** like on/off pumps, pumps with variable frequency drives (VFDs) or valves capable of modulating flow,
4. **PLCs** that can accept remote setpoints and enforce safety protocols, connected to the SCADA. These are also used to implement fallback strategies if a communication loss occurs.

In addition, the infrastructure must already possess means of **storage (e.g. tanks or large pipes where sewage can be stored)**.

If and when the sewer network possesses all the described elements, then the following can be implemented:

5. **The DSC (supervisory control)** installed on a local computer, responsible for real-time predictive forecasting, optimization and coordination across multiple assets,
6. **Fallback strategies**, which are predefined "safe modes" to ensure stability during failures. Fallback strategies are explained further after this section.
7. **Operator training and procedures**: Clear guidelines for switching between control modes and handling exceptions.

Dynamic control can be introduced gradually, starting with a few controllable assets and expanding as experience and infrastructure maturity grow. In other words, the DSC will only implement according to agreed objectives of the wastewater network.

How Grundfos prepares a sewer network to be technologically ready for dynamic control

Below is a simple sewer infrastructure with commonly found assets for employing static control:

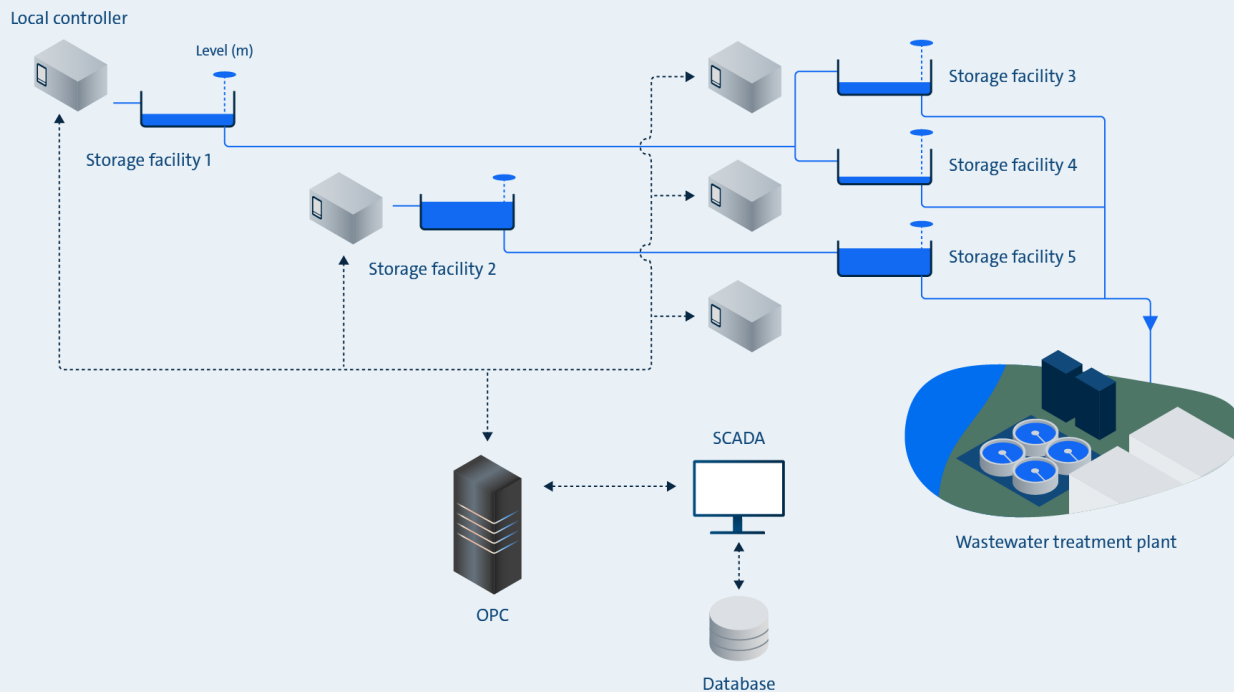

Here is the same set-up now with dynamic control implemented:

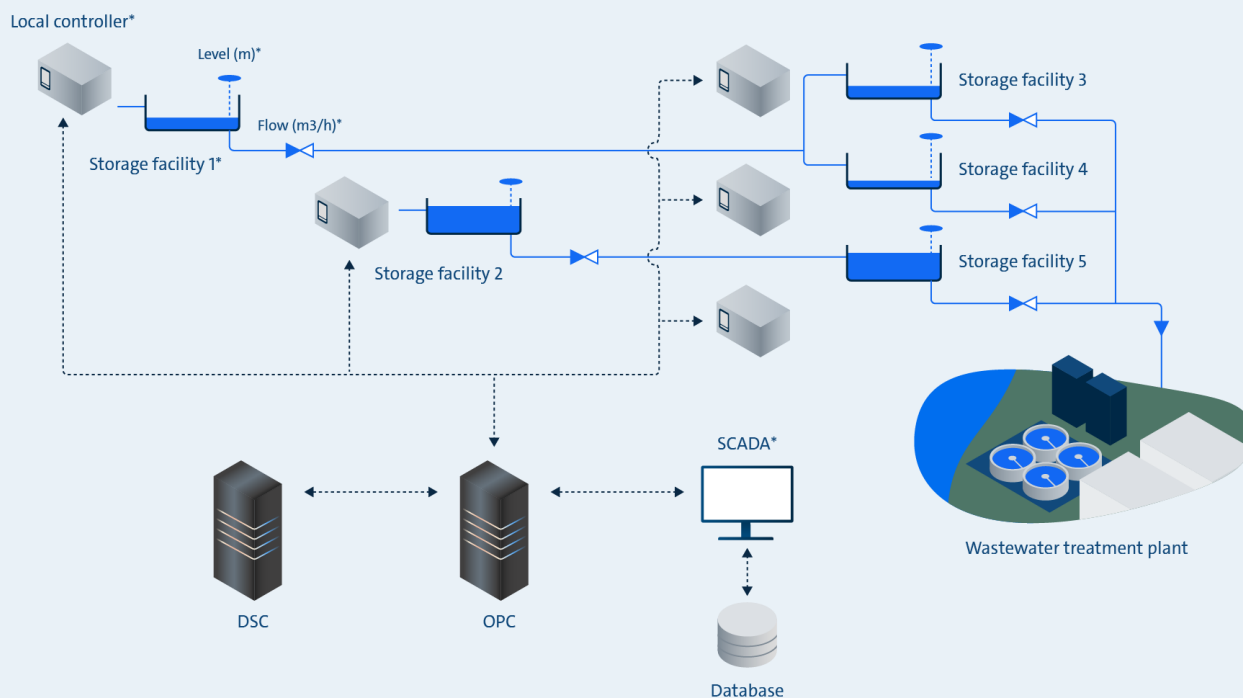

*Must be installed or connected as a prerequisite to DSC

Robustness and Resilience in Dynamic Control

The DSC solution is designed to not only optimize wastewater operations but also do so without compromising the sewer system. The solution is designed and tested for operational realities like communication loss, asset malfunction like sensor failure, adjustment of parameters such as the maximum inflow to the WWTP, as well as providing the operator with the power to enable or disable the DSC from regulating the system.

Tests for such operational conditions can be found in later sections of this paper. This section serves to illustrate the setup of assets connected to the DSC, how assets co-operate and how this setup ensures a robust and resilient network.

To understand how the DSC solution can optimize a network with suboptimal operating conditions in static control, it is important to explain how connected devices communicate and co-operate with each other.

Standardized communication through OPC-UA

Communication between local controllers and the DSC is standardized through ISO-standard OPC-UA. This ensures that variables are efficiently managed and ensures that any information relayed to the supervisory controller is conveyed in a consistent, predictable format and vice versa.

This consistency means that...

1. There is less complexity in documenting and managing multiple instances of variables by standardizing the information format.
2. Changes to variables like setpoints—whether made by the operator manually or the DSC—only need to happen in one place, not in multiple places.
3. Every part of the network sends an expected data format and retrieves only information in the format that it expects to receive. This ensures that the system is a closed loop and any other information is therefore ignored/cannot affect the system.

While the OPC-UA is the preferred mode of communication, it is possible to develop an interface based on another standard communication protocol or to change the order of communication. This could be DSC-PLC with the SCADA as observer, or DSC-SCADA-PLC with a proprietary protocol between SCADA and PLC.

Connectivity and control communication

Every station controllable by the DSC maintains two variables that serve as life counters. One variable is incremented by the station, and the other is incremented by the DSC. The life counters inform the asset that the other party is still alive and that communication between them is functional.

One can think of this as performing a greeting—if both parties wave at each other, communication is functional. If only one or none of the parties wave, then communication is nonfunctional. The station additionally manages a third variable, the “Control Mode”, which informs the DSC and the operator of its current mode of operation or “state”.

When there is a communication failure, the PLC recognizes this via the life counter and changes the state of the station to a fallback state. In software terms, we say that the DSC has a finite state machine.

Control hierarchy and control modes

1. The operator is informed if the DSC is connected to any given station, and the station’s operation status is known.
2. The operator can disable the DSC at any time for any given station.
3. The operator can manually control the station setpoints remotely.
4. The stations do not depend on the DSC to operate.
5. Stations can autonomously “override” the DSC, under certain conditions to prioritize its local programming. A simple example would be to refuse turning on a pump when the wet well is empty.

Essentially, the DSC must be “permitted” by the operator and the local station to optimize the network and stations can continue to operate with or without input from the DSC.

To ensure robustness and continuity of operation, the DSC sends, simultaneously with the instructions, information to be used by the station in case of communication loss. This ensures consistent behavior, even in degraded communication situations and gives the DSC the ability to know, predict and optimize network performance also in such degraded situations.



The DSC and every controllable station keep a “life counter” to confirm functional communication - think of it like performing a mutual greeting.

Functional communication

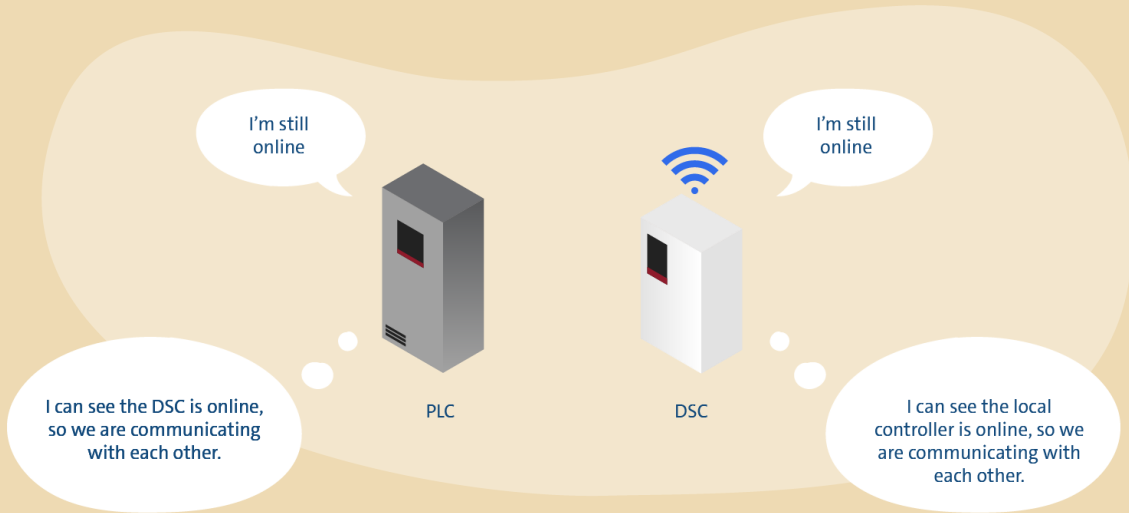

Degraded communication

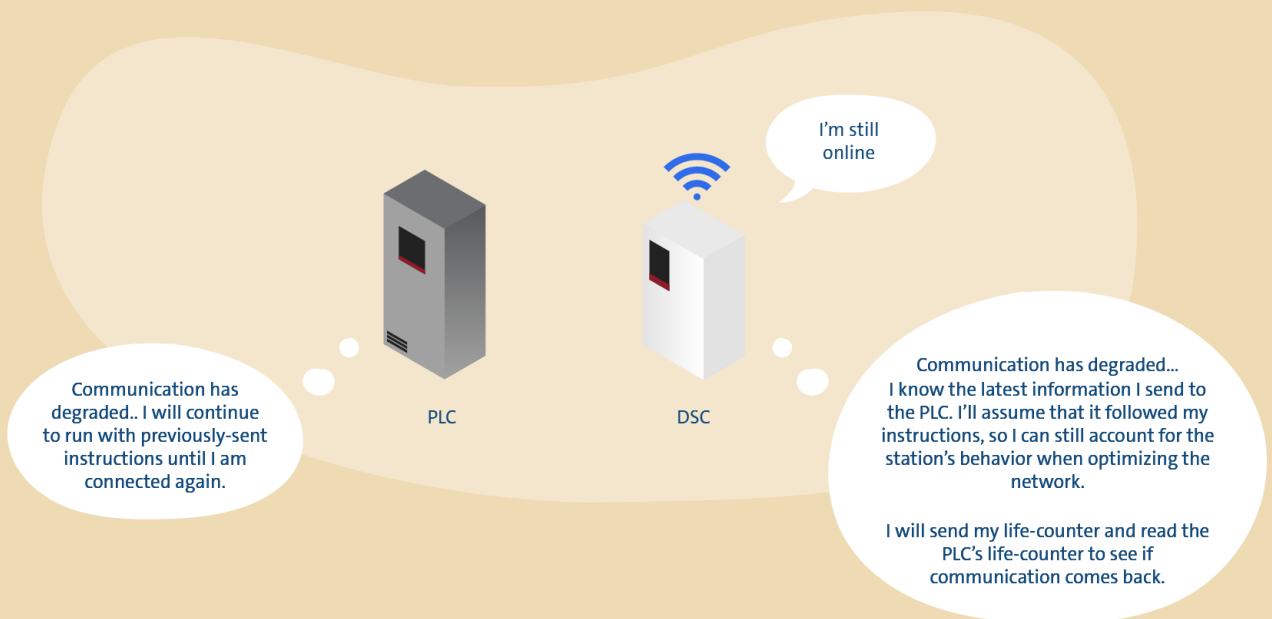

DSC-controllable stations manage a variable for its state, which offers insight on how the station is being run

Local control

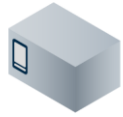

Offline (0)

The station is offline and therefore cannot be controlled. The DSC does not consider any data from this structure.

Local control



Maintenance (1)

The station is in a Maintenance state, which can represent that an operator is onsite and has taken over the operation of the station.

For the DSC, this means that this station cannot be controlled at this time. Since the station is operated manually, its behavior cannot be predicted, but it can consider historical data in the optimization.

Local control



Auto-local (2)

The station is in an Auto-local state, and running with its own local setpoints.

The DSC cannot control the structure in this state. However, unlike the Maintenance state, there is a clearly defined behavior with available parameters, which gives DSC the ability to consider its behavior into the overall network, as well as predict its behavior.

Local control



Fallback_II (3)

Fallback_I (4)

The station is in Fallback control mode. A station may switch into these control modes if communication loss occurs.

Fallback_I and Fallback_II are both agreed fallback functions, with different setpoints. Fallback_II is implemented when communication loss continues for a longer period of time.

These states ensure that the station will still operate, despite communication loss. When communication is re-established, the station automatically returns to state Controllable.

Local control



Controllable (5)

Controlled (6)

The station is controllable by the DSC, or is already controlled.

The operator can, at anytime, enable the DSC by putting a station from Auto-Local to Controllable.

Vice-versa, the operator may take a station in Controllable into Auto-Local or Maintenance.



The Test Setup

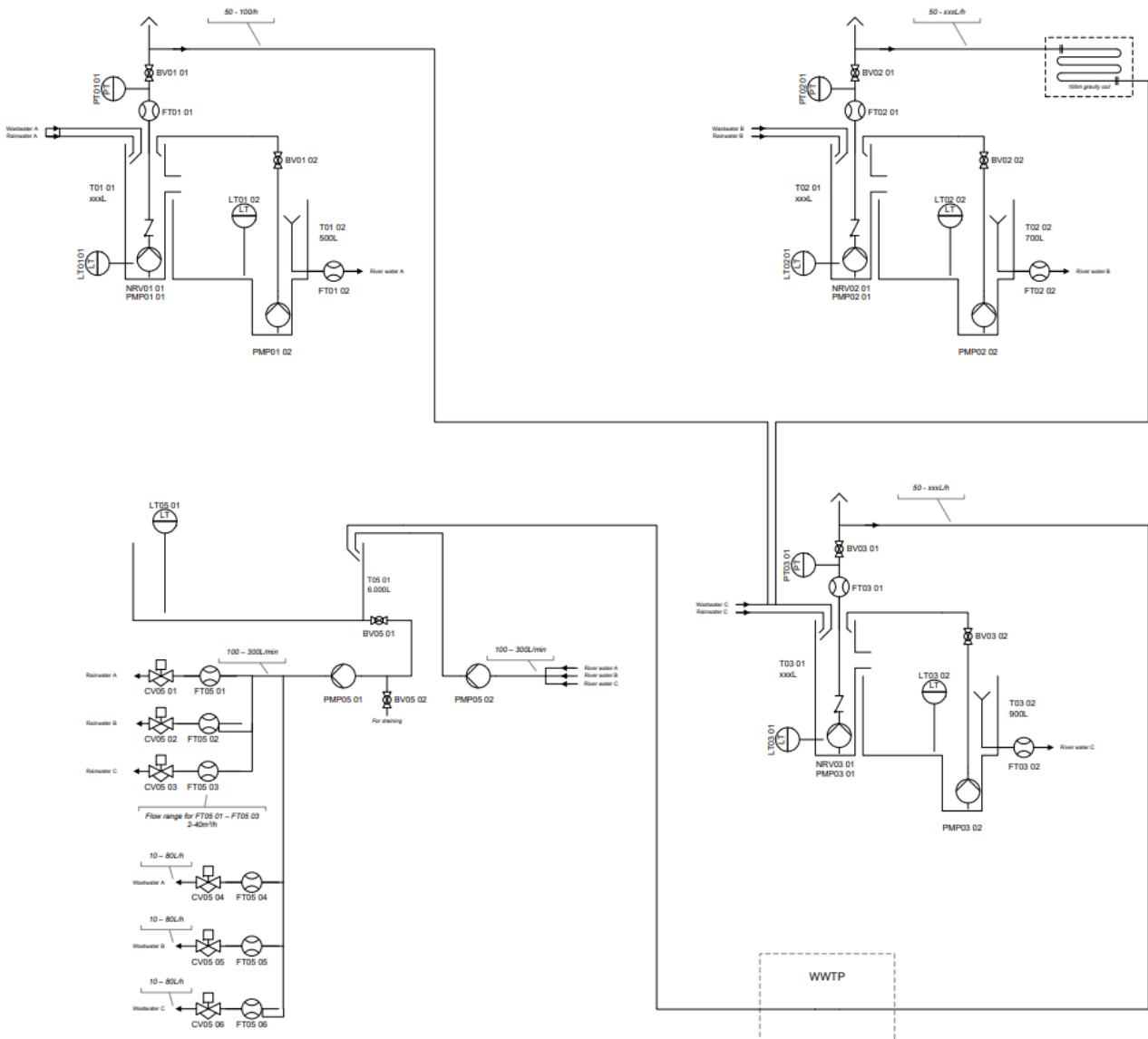

Figure 1: Piping and Instrumentation Diagram (P&ID) of the DSC Test Setup.

Hydraulic and Operational Performance Tests

Introduction

To evaluate the DSC for both its hydraulic and operational performance, a scaled-down wastewater network is constructed in the Grundfos prototype lab. We evaluate whether the DSC can:

1. **Perform dynamic control** that actively optimizes available storage across a network during rain events.

2. **Forecast and utilize travel time** between assets to anticipate peaks and shift volumes.
3. **Remain robust in suboptimal operational conditions** e.g. network/SCADA interruptions, maintenance states, sensor failures.
4. **Provide effective fallbacks** in conditions where communications degrade or local measurements fail, ensuring that stations continue operating in safe, predictable modes and maintain network stability.

We evaluated the following scenarios and tested for the network's performance. For hydraulic performance, we compared the network without vs. with the DSC. For operational performance, we tested the network's behavior in operational downtimes.

Hydraulic Performance:

- Baseline performance comparison, i.e. performance with and without the DSC implemented,
- Ability to adapt to a simulated infrastructural change through increased travel time between pumping stations,
- Changed catchment properties with better control opportunities,
- Ability to "prioritize" where there is differentiated sensitivity in receiving water bodies.

Operational Performance:

- Operations with short IT-network disconnection,

- Operations with long IT-network disconnection,
- Sensor failure test.

Test setup

The scaled-down wastewater network consists of three water catchments, which act as CSO tanks. We may refer to the catchments as *Pumping Stations* or *Stations*, i.e. Station 1, Station 2, and Station 3. Station 1 and Station 2 are connected to Station 3, with Station 3 connecting to the inflow to the WWTP.

All 3 tanks are connected to a source water tank, which replicates a supply of waste and rainwater flow to the tanks to simulate both dry and wet weather operations of a wastewater network. For this laboratory setting, water is used in lieu of actual waste/rainwater.

Water level and flow sensors are installed in each tank and all pumps in the system are connected to a local



Figure 2: Overview of the DSC test setup

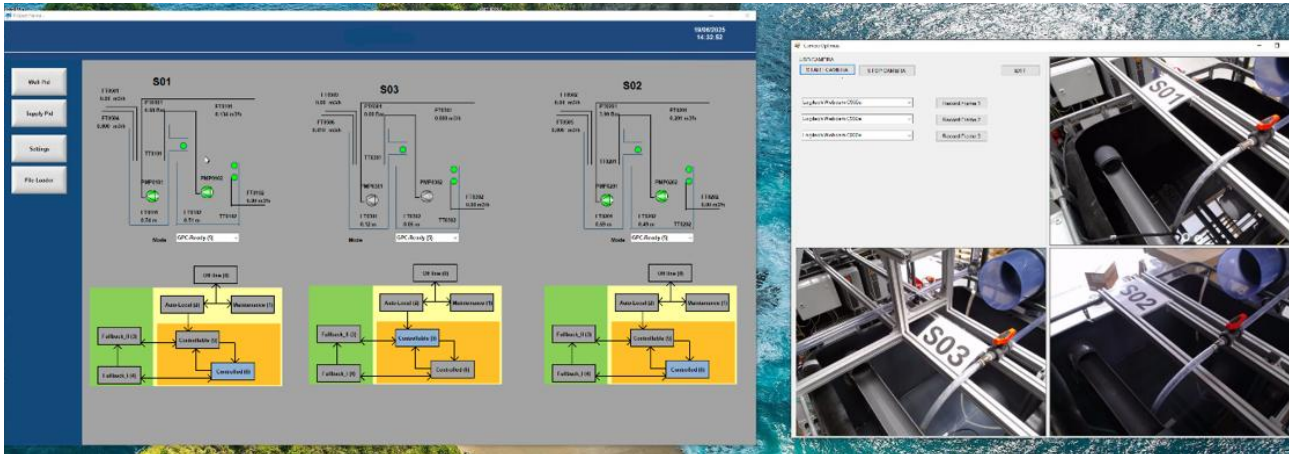

Figure 3: Screen capture of the SCADA system and cameras setup for the DSC for remote control. The SCADA system also displays the “Control mode” of the DSC, which an operator can select for a particular pumping station: DSC mode, offline, maintenance mode and local static control mode.

PLC and controlled by a SCADA system. The PLC is also specifically programmed to adapt to the DSC requirements. It is important to note that the fallback strategy of the PLC is only partially implemented in this setup.

The DSC solution is then connected to the SCADA system via an OPC-UA server.

Hydraulic performance of dynamic control

This evaluation focuses on the hydraulic performance of the DSC algorithm, conducted in a controlled laboratory setting that simulates four different scenarios. Each scenario features varying rainfall-runoff patterns and distinct physical setups, including different transport times within the system and varying pump capacities.

The four scenarios are as follows:

Baseline scenario with three consecutive rain events

- Objective: Evaluate benchmark performances of the initial network setup with a simulated rain event, with the DSC and without.
- Scenario: Three consecutive rain events over each catchment with decreasing lag times between rain events to simulate an actual rain event.

Increased travel time between tanks 2 and 3

- Objective: Demonstrate the DSC’s ability to adapt to a modified network as well as its ability to utilize travel time between tanks.
- Scenario: Increased travel time between Station 2 and Station 3.

Changed catchment properties with better control opportunities

- Objective: Demonstrate how the DSC is influenced by the "freedom to control" within the system.
- Scenario: Changed catchment properties with an increased inflow to Tank 1 and decreased inflow at Tank 2.

Differentiated sensitivity in receiving water bodies

- Objective: Demonstrate the DSC’s ability to prioritize certain water bodies and effects of prioritization.
- Scenario: Station 1 is prioritized to have less overflows, compared to Station 2 and Station 3.

Each scenario is tested with and without the DSC software, where in the latter case, the pumps are controlled by basic static level control, representing a traditional control method. This comparison evaluates the improvements offered by the DSC algorithm over conventional static control.

Scenario 1

Baseline scenario with three consecutive rain events

Objective

Evaluate benchmark performances of the initial network setup with a simulated rain event, with the DSC and without. This setup demonstrates how rainfall dynamics, including spatial distribution and rain front movement over a city, impact the system. It also shows how dynamic control leverages these patterns and how incompletely emptied tanks between events affect the system.

Scenario

- Rain travels over three different catchments sequentially: first Station 1, then Station 2, and finally Station 3.
- There is a lag time between when the catchments receive rain. For the first rain event, there is 60 minutes before the rain moves from Station 1 to Station 2, and 60 minutes from Station 2 to Station 3, and then 60 minutes before it returns to Station 1.
- The network experiences two more rain events. For the second and third rain event, the lag times are 40 and 20 minutes respectively.
- The rain intensity and depth remain consistent between the events.

This rain runoff is then measured from each individual catchment, measured at the tank inlet. Each

measurement is taken as an average of over 15 minutes. A model used to estimate the runoff additionally accounts for hydrological factors such as ponding and soil saturation, as water has been used in lieu of actual rainwater.

The resulting rainfall runoff from the rain event is visualized in Figure 4. This runoff shows how much rainfall each catchment receives. This is also to show, that the lag times have been decreased between each rain event to lead to more equal rainfall distribution.

With and without the Dynamic Sewer Control

We now evaluate for the overflow that occurs. The network undergoes the rain scenario in two separate instances, once without and once with the DSC. Overflow from each catchment is aggregated into a total, then compared against each other to assess the DSC's performance.

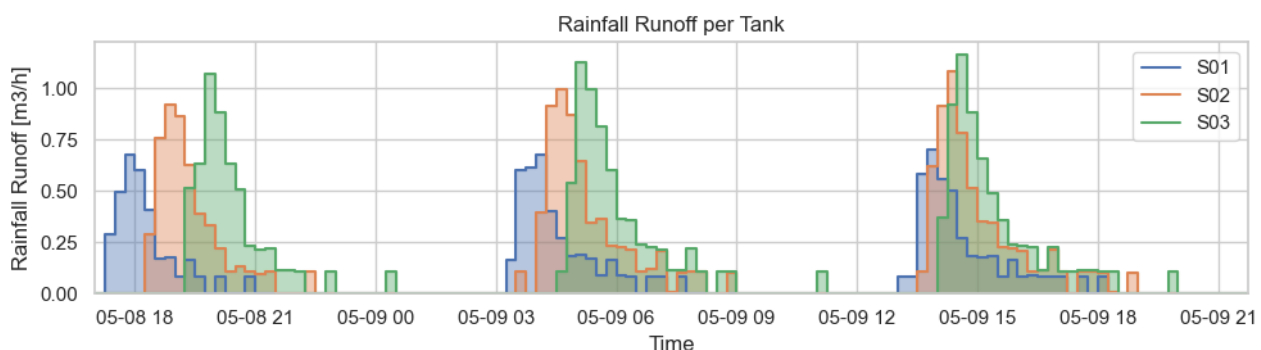

Figure 4: Rainfall runoff from each individual catchment measured at the tank inlet. The visualized values are 15-minute averages.

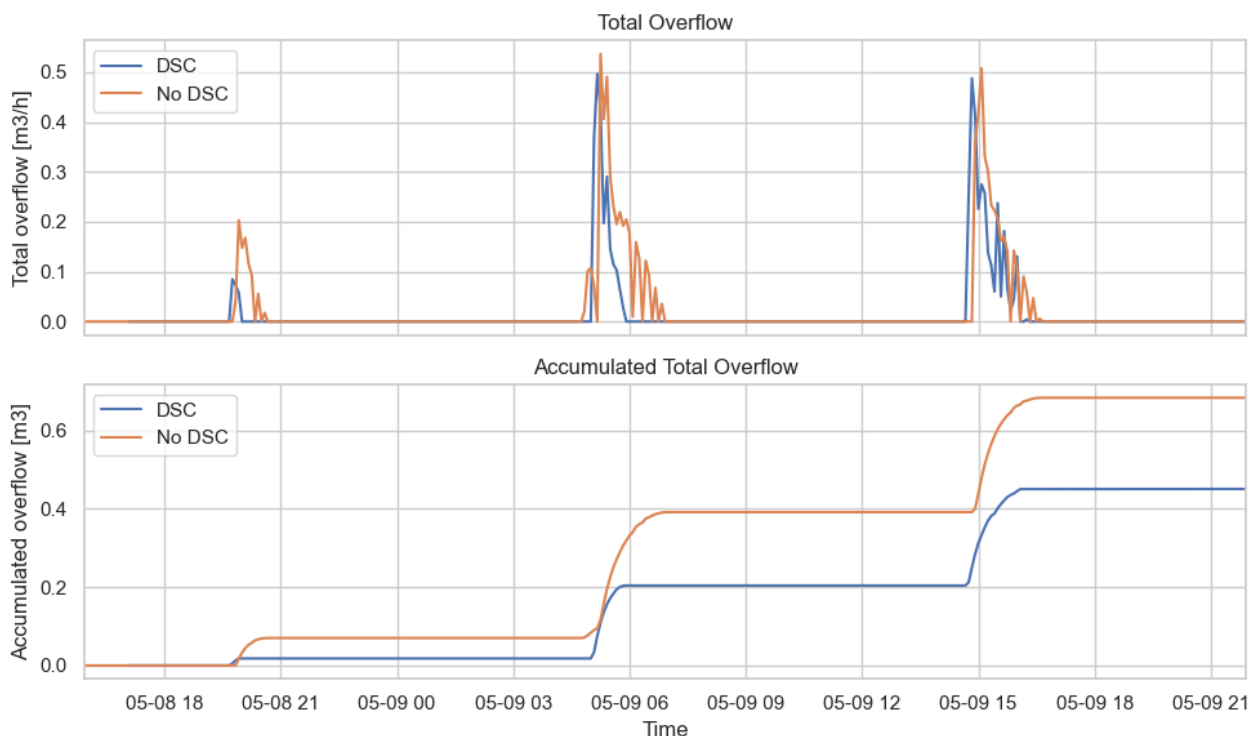

Figure 5: Total overflow and accumulated total overflow from the three tanks during the three consecutive rain events with and without DSC. The visualized values are 5-minute averages.

Figure 5 shows the total overflow and accumulated total overflow during the three consecutive rain events. The results show that total overflow is reduced with the DSC, from 0.73 m^3 without to 0.48 m^3 with. This corresponds to a 35% reduction.

To understand how the total overflow is decreased, the filling degree of the three tanks during the test is evaluated. This is shown on Figure 6. The figure shows that during all three rain events, the volume in Station 2 is evacuated faster with the DSC than without. This happens as there is free capacity downstream in Station 3. This shows that the DSC software can equalize the load on the tanks, as far as the rest of the infrastructure (pumps and pipe network) allows for it.

Even though Station 2 is evacuated faster with the DSC than with traditional control, the capacity of Station 3 is clearly not fully utilized. This is due to other limitations in the system, in this case the capacity of the pump at Station 1 and 2 and hence the tanks are over-dimensioned. When considering dynamic control in the design phase of a system, it is possible to reduce

the sizes of tanks required to manage overflow effectively. This approach could potentially eliminate the need for oversized tanks. Instead, installing a pump with a higher capacity, provided the network infrastructure supports it, can further optimize the system's performance and minimize overflow.

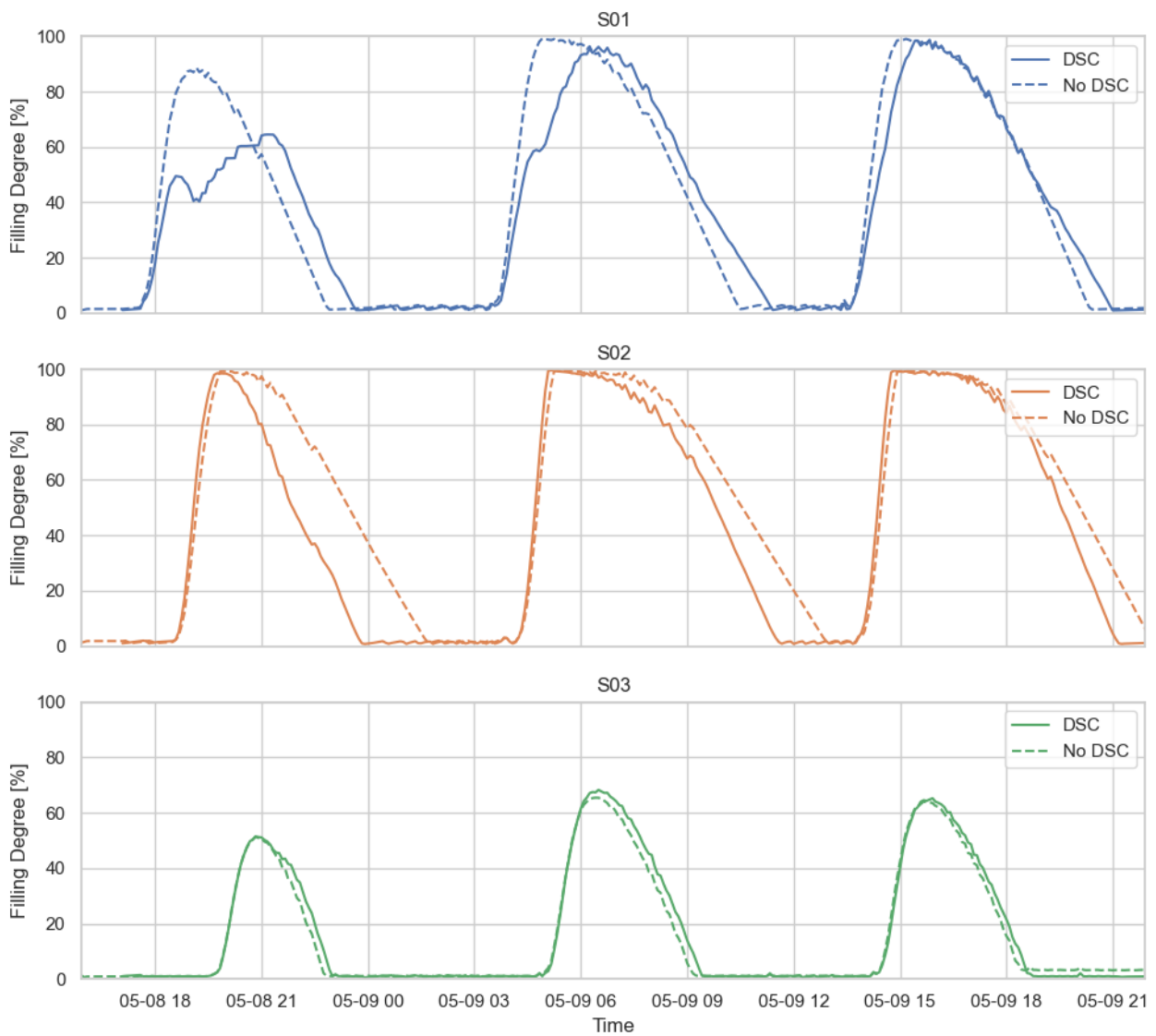

Figure 6: Calculated filling degree for the three tanks during the three consecutive rain events. The visualized values are 5-minute averages.

Scenario 2

Increased travel time between tanks 2 and 3

Objective

Evaluate the network's hydraulic performance, with and without the DSC. This time, the network has been modified to include a longer travel time between Station 2 and Station 3, to demonstrate the DSC's ability to adapt to a modified network as well as its ability to utilize travel time between tanks.

Scenario

- For this scenario, rain travels over the three catchments sequentially: first Station 1, then Station 3, and finally Station 2.
- There is a lag time between when the catchments receive rain. For the first rain event, there is 60 minutes before the rain moves from Station 1 to Station 3, and 60 minutes from Station 3 to Station 2, and then 60 minutes before it returns to Station 1.
- The network experiences two more rain events. For the second and third rain event, the lag times are 40 and 20 minutes respectively.
- The rain intensity and depth remain consistent between the events.

- Travel time between Station 2 and Station 3 has been increased by installing a coil representing a longer gravity system between the two tanks.
- Furthermore, the pumping capacity at Station 2 has been decreased to the maximum that the coil allows (from 323 L/h to 200 L/h).

This scenario results in a different runoff pattern than the first scenario. Compared to the runoff in the first scenario, the volume in Tank 3 increase earlier and hence leaves less capacity for the DSC to utilize to evacuate the volume in Tank 1 and 2. The rainfall runoff is showed in Figure 7.

With and without Dynamic Sewer Control

We evaluate for the overflow that occurs. The network undergoes the rain scenario in two separate instances, once without and once with the DSC. Overflow from each catchment is aggregated into a total, then compared against each other to assess the DSC's performance.

The test results show a total overflow volume of 0.67 m³ without and 0.48 m³ with the DSC, resulting in a total overflow reduction of 28%. This is visualized in Figure 8.

It is also demonstrated that the overflow during the first of the three consecutive rain events is almost

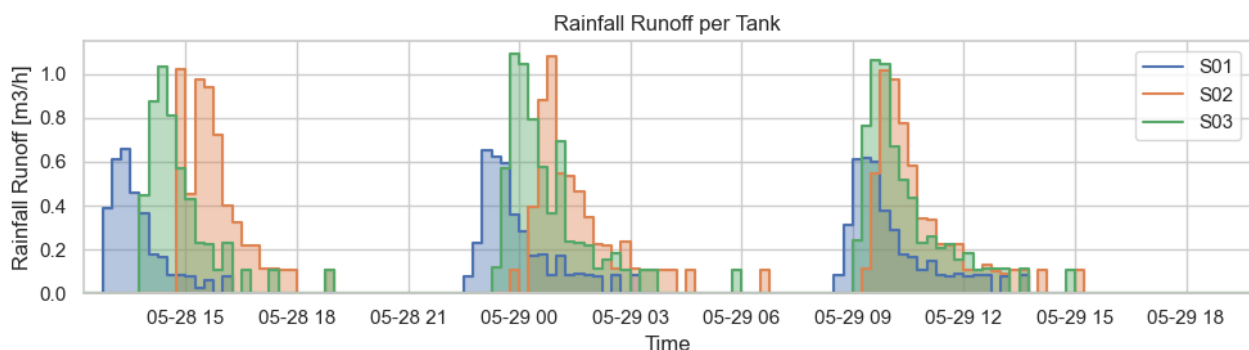

Figure 7: Rainfall runoff from each individual catchment measured at the tank inlet. The visualized values are 15-minute averages. Note the difference from the previous scenario, that the runoff starts at Tank 3 before Tank 2.

eliminated. This is because the volume starts to fill later in Station 2. As the travel time between Tank 2 and 3 is increased, the DSC can then evacuate Station 1 before the volume is increased in Station 2, and then it can empty Station 2 afterwards. This appears on Figure 9, which shows the filling degree of the three tanks during the scenario.

Compared to Scenario 1, this scenario shows the impact of the time delays in the system and how the DSC can utilize the time to sink between tanks, to optimize the storage capacity. We also show that the DSC has readily adapted to this change, and reduces overflows regardless of network setup.

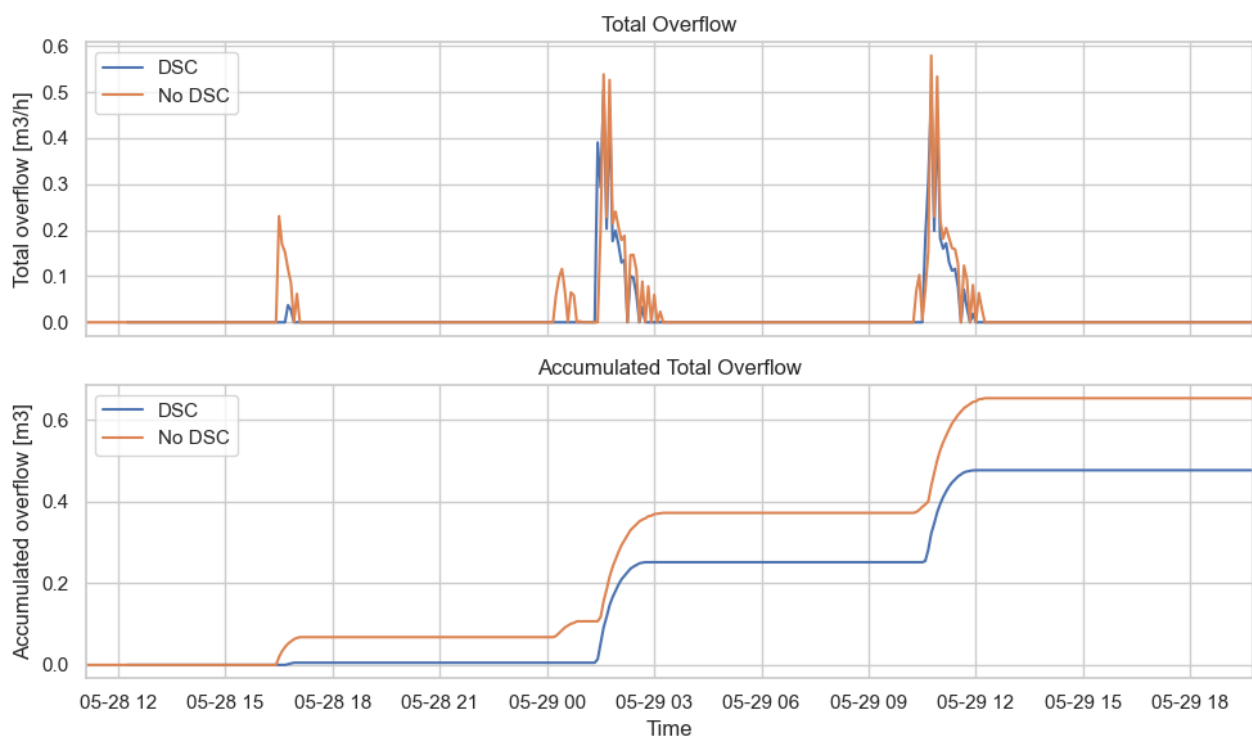

Figure 8: Total overflow and accumulated total overflow from the three tanks during the three consecutive rain events with and without DSC. The visualized values are 5-minute averages.

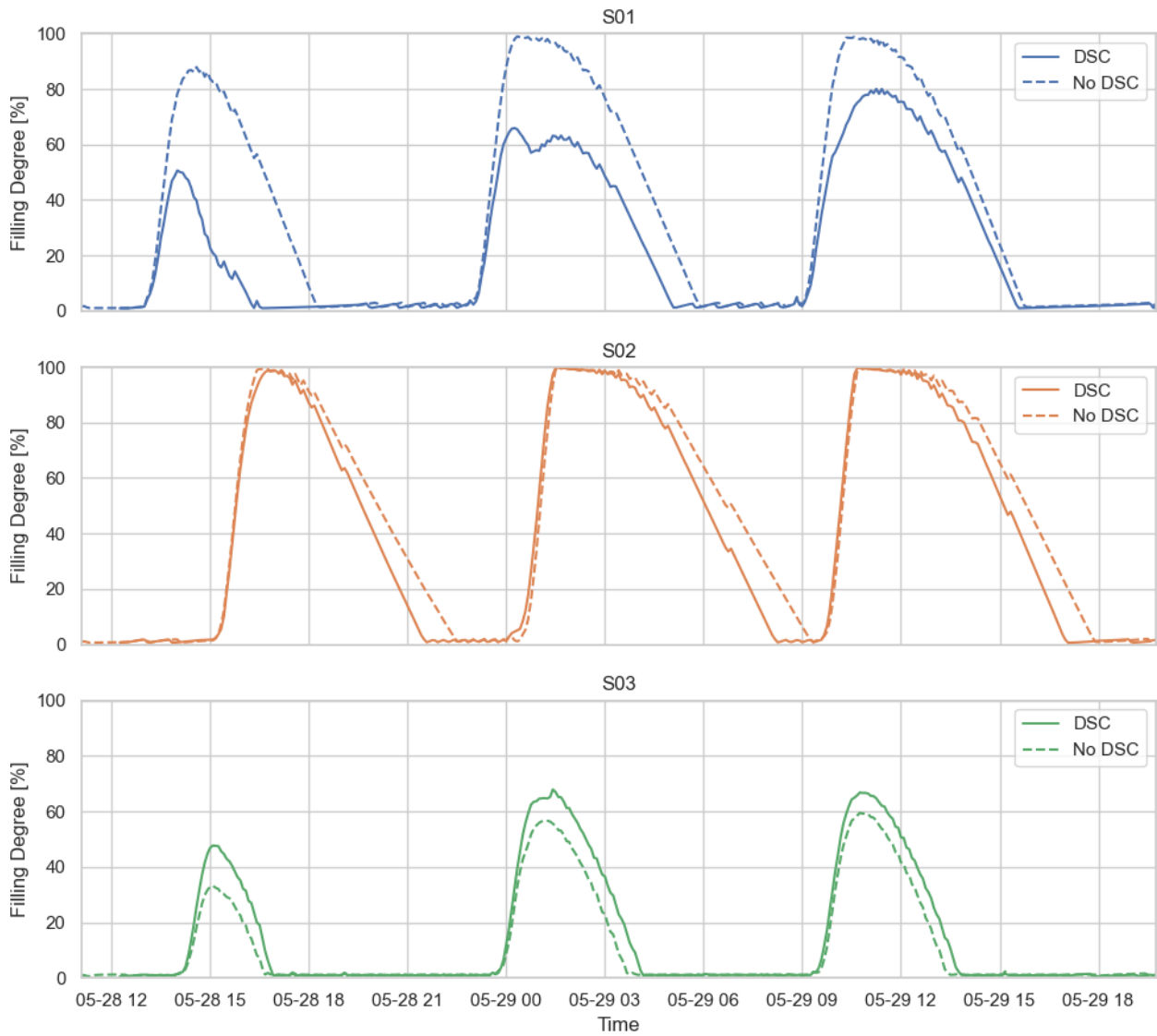

Figure 9: Calculated filling degree for the three tanks during the three consecutive rain events. The visualized values are 5-minute averages.

Scenario 3

Changed catchment properties with better control opportunities

Objective

This scenario is designed to demonstrate how the DSC is influenced by the "freedom to control" within the system. In this case, Station 1 is less restricted compared to Station 2 in terms of its ability to increase outlet flow, highlighting the system's varying control capabilities. This scenario mirrors the precipitation pattern of Scenario 2, with the total runoff from all catchments remaining unchanged.

Scenario

- Rain travels over the three catchments sequentially: first Station 1, then Station 3, and finally Station 2.
- There is a lag time between when the catchments receive rain. For the first rain event, there is 60 minutes before the rain moves from Station 1 to Station 3, and 60 minutes from Station 3 to Station 2, and then 60 minutes before it returns to Station 1.
- The network experiences two more rain events. For the second and third rain event, the lag times are 40 and 20 minutes respectively.
- The rain intensity and depth remain consistent between the events.

- Travel time between Station 2 and Station 3 has been increased by installing a coil representing a longer gravity system between the two tanks.
 - Furthermore, the pumping capacity at Station 2 has been decreased to the maximum that the coil allows (from 323 L/h to 200 L/h).
- Tank 1's catchment receives more water, while Tank 2 receives less.

The rainfall runoff is showed on Figure 10.

Table 1 shows the total inflow to each tank during the previous scenario (Scenario 2) and the current scenario (Scenario 3). This is to demonstrate how the changed catchment properties, despite the identical runoff scenario, resulted in an increased inflow to tank 1 and decreased inflow at Tank 2 respectively in Scenario 3.

With and without Dynamic Sewer Control

We evaluate for the overflow that occurs. The network undergoes the rain scenario in two separate instances, once without and once with the DSC. Overflow from each catchment is aggregated into a total, then compared against each other to assess the DSC's performance.

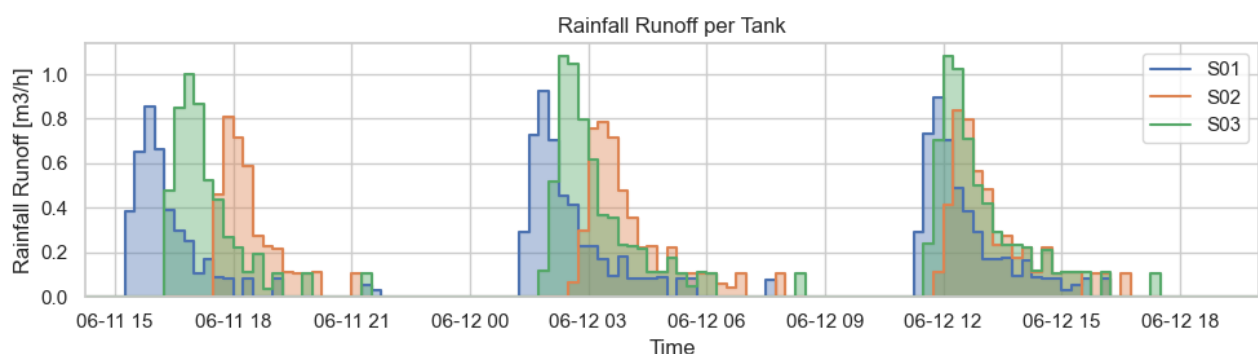

Figure 10: Rainfall runoff from each individual catchment measured at the tank inlet. The visualized values are 15-minute averages.

Scenario	Tank 1	Tank 2	Tank 3	Total
Scenario 2	11.3 m ³	18.0 m ³	18.7 m ³	48.0 m ³
Scenario 3	14.2 m ³	13.9 m ³	18.4 m ³	46.5 m ³

Table 1: Total inflow to the tanks. The data is derived from inflow measurements to the tanks, which results in slight variations in the total volume due to measurement uncertainties and deviations in inflow control during the runs.

The test results show a total overflow volume of 0.61 m³ without and 0.19 m³ with the DSC, resulting in a total overflow reduction of 69%. Figure 11 and Figure 12 shows that the total overflow during the first rain event is completely removed.

dependent on having actual physical possibilities to optimize—in this case, the presence of water in specific locations and controllable assets that can move the water to places with free capacity.

In this scenario, Tank 3 is significantly better utilized, since it is possible to evacuate Tank 1. This contrasts with Scenario 2, where there was not enough water to evacuate from Tank 1 to fill Tank 3. This scenario demonstrates how the system’s performance is highly

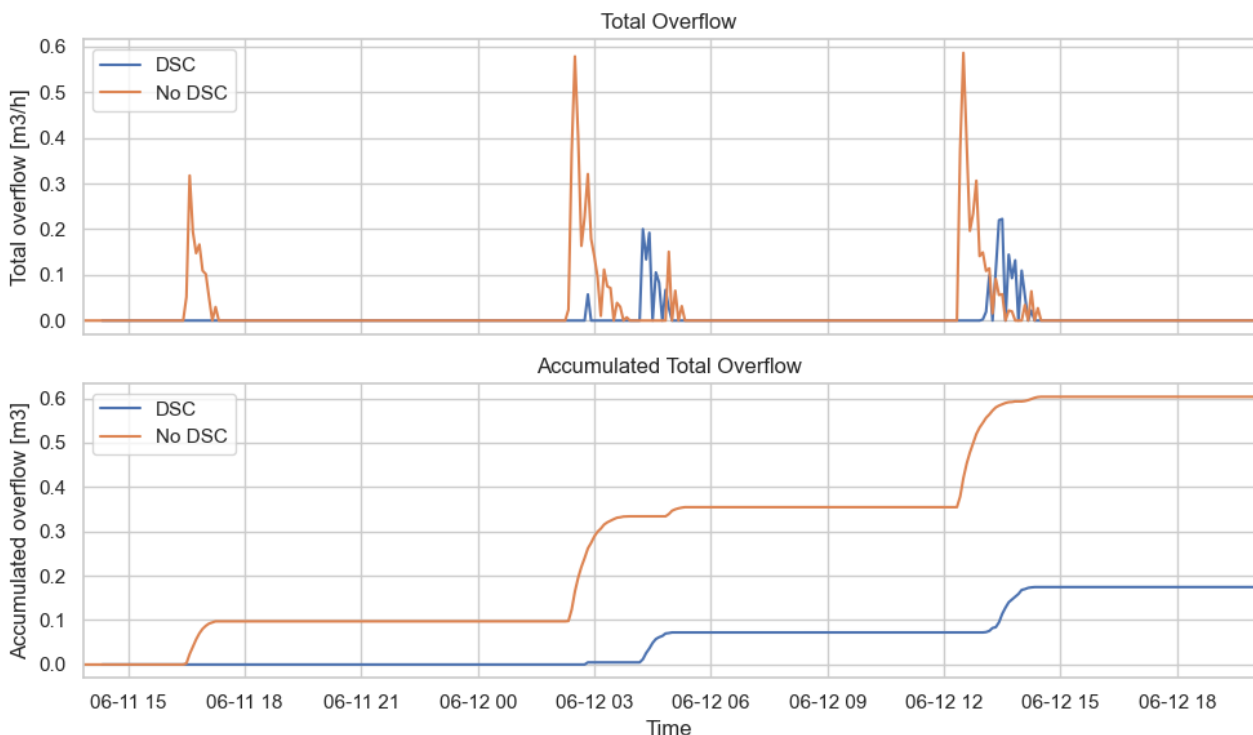

Figure 11: Total overflow and accumulated total overflow from the three tanks during the three consecutive rain events with and without DSC. The visualized values are 5-minute averages

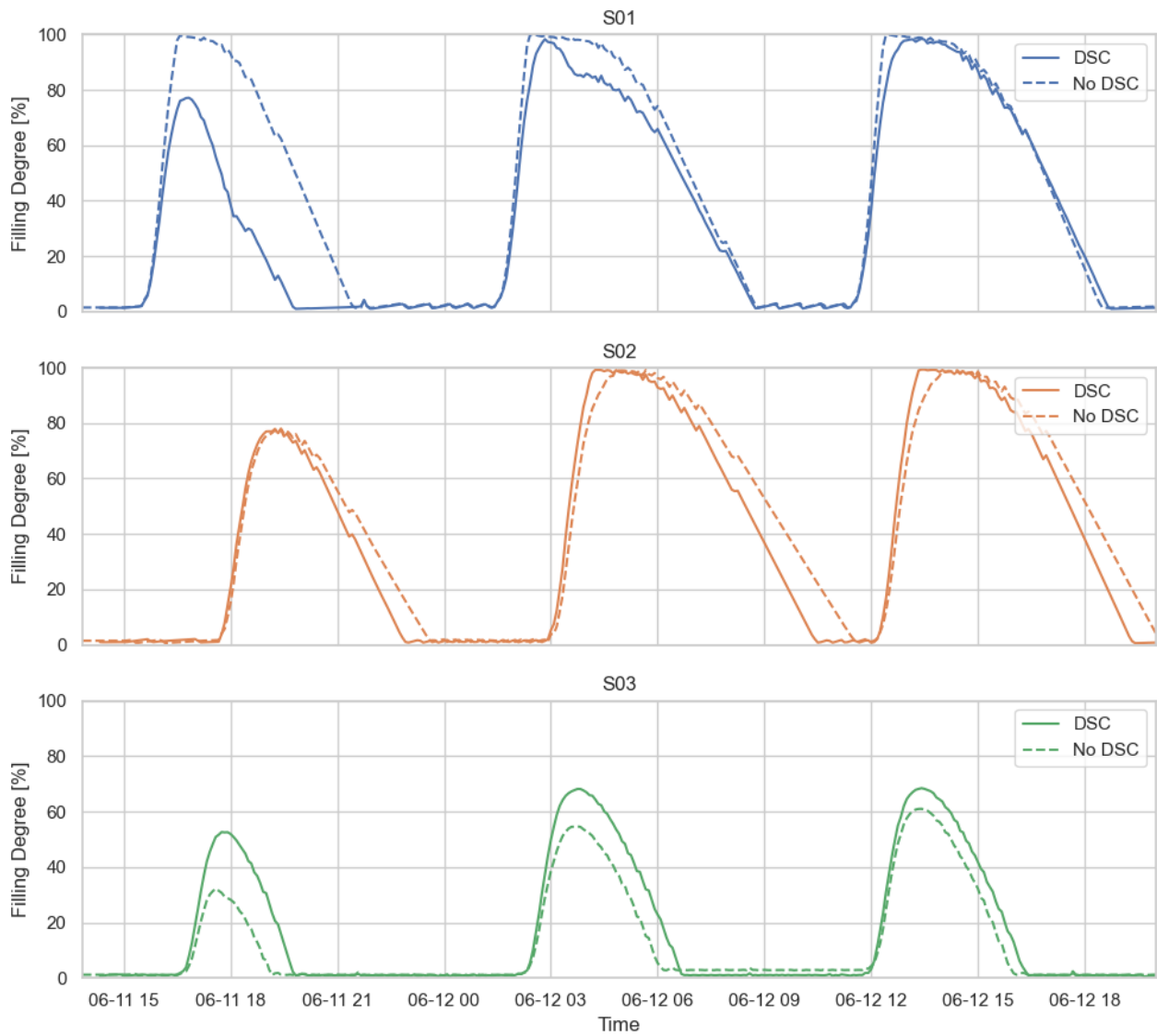

Figure 12: Calculated filling degree for the three tanks during the three consecutive rain events. The visualized values are 5-minute averages.

Scenario 4

Differentiated sensitivity in receiving water bodies

Objective

One of the notable features of the DSC is its ability to prioritize overflow reduction at specific locations. This functionality is particularly beneficial in areas where the receiving waterbody is highly sensitive to wastewater overflows, such as ecologically fragile zones or areas with stricter regulatory requirements.

By leveraging this feature, the DSC ensures that overflow is minimized at these critical locations, protecting the environment and adhering to sustainable management practices. This is achieved through a dynamic redistribution of inflows, ensuring that storage and evacuation capacities are optimized across the system.

Scenario

- Rain travels over the three catchments sequentially: first Station 1, then Station 3, and finally Station 2.
- There is a lag time between when the catchments receive rain. For the first rain event, there is 60 minutes before the rain moves from Station 1 to Station 3, and 60 minutes from Station 3 to Station 2, and then 60 minutes before it returns to Station 1.
- The network experiences two more rain events. For the second and third rain event, the lag times are 40 and 20 minutes respectively.
- The rain intensity and depth remain consistent between the events.

- Travel time between Station 2 and Station 3 has been increased by installing a coil representing a longer gravity system between the two tanks.
 - Furthermore, the pumping capacity at Station 2 has been decreased to the maximum that the coil allows (from 323 L/h to 200 L/h).
- Tank 1 is prioritized to have an overflow reduction.
 - The sensitivity of the receiving water body at Tank 1 is twice as high as for Tank 2 and 3.

In contrast to previous scenarios, this scenario is not compared to a traditional static control approach. but to a DSC test with equal sensitivity across the three tanks.

With and without prioritization

We evaluate for the overflow that occurs. The network undergoes the rain scenario in two separate instances, once without and once with prioritization at Tank 1. Overflow from each catchment is aggregated into a total, then compared against each other to assess how prioritization affects overflows within a network.

Figure 13 shows that by introducing differentiated sensitivity, there has been a slight decrease in overflow from Tank 1, while there has been an increase in the overflow from Tank 2. A summary of the overflow volumes is presented in Table 2. From the table, it shows that the DSC has obtained a 5% reduction in overflow from Tank 1, which is expected due to the sensitivity setup during the run. It also shows that the cost of prioritizing overflow reduction from Tank 1 is 12% increase in overflow from Tank 2. The total overflow from all tanks has been increased by 11% by prioritizing overflow reduction at Tank 1.

Accumulated overflow	Tank 1	Tank 2	Tank 3	Total
Equal sensitivity	0.019 m ³	0.16 m ³	0.00 m ³	0.18 m ³
Differentiated sensitivity	0.018 m ³	0.18 m ³	0.00 m ³	0.20 m ³
Relative difference	5.3%	-12.5%	0%	-11.1%

Table 2: Accumulated overflow from the three tanks with and without differentiated sensitivity.

This test demonstrates that prioritization overflow reduction at specific locations is possible. However, it does not guarantee a globally optimal solution. Consequently, this may lead to increased overflow at other locations within the system. However, for this test, we'd like to demonstrate that the DSC is able to prioritize certain stations.

Conclusion

The results demonstrate that the DSC system functions can effectively reduce total overflow in various scenarios. In Table 3 a summary of the results from Scenarios 1-3 shows a total overflow reduction in the range of 28-69%, validating the functionality of the optimization system used in the DSC. The tests have shown that the DSC is also able to prioritize reduction

at specific sites. However, this is a matter more related to the management of a wastewater system rather than algorithm capabilities, as the operator must define the optimization objective.

Despite the DSC showing impressive performance in the laboratory tests conducted in this study, it is important to note that the performance of the software is limited to the system's inherent potential for reduction. This potential is significantly influenced by factors such as unutilized capacity, operational flexibility and the specific hydrological events that it is set to handle. In essence, while the DSC can optimize the management of overflow, its efficacy is inherently tied to the limitations of the system.

Accumulated overflow	Total overflow without	Total overflow with DSC	Relative reduction
Scenario 1	0.73 m3	0.48 m3	35%
Scenario 2	0.67 m3	0.48 m3	28%
Scenario 3	0.61 m3	0.19 m3	69%

Table 3: Overview of overflow reduction in scenarios 1-3 with the use of DSC.

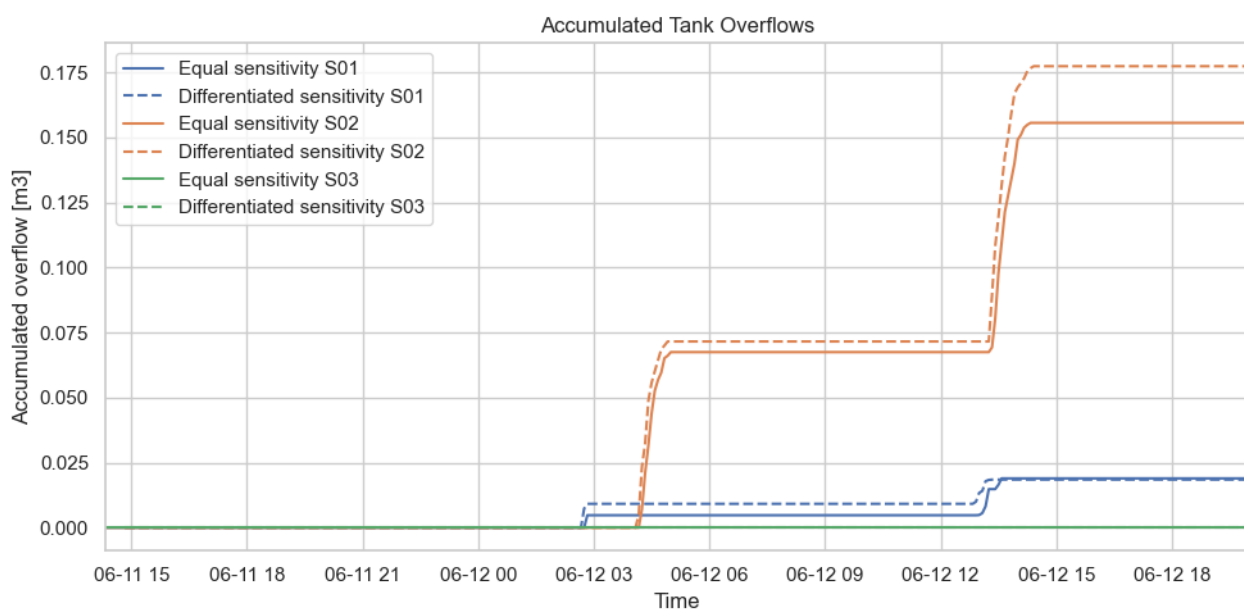

Figure 13: Accumulated overflow from the three tanks with and without differentiated sensitivity.

Operational performance of software integration

This evaluation focuses on assessing the operational robustness of the DSC algorithm within a controlled laboratory environment, specifically simulating various realistic operational failure scenarios. Note that “network” here is used to mean an IT network. The operational failure scenarios tested include:

Network Disconnection (short)

- Objective: Evaluate the local PLC’s ability to manage control independently and the system’s resilience upon reestablishing communication. Compare hydraulic conditions to a failure-free scenario.
- Scenario: The DSC is disconnected from local pumping stations’ PLCs for a duration of 30 minutes due to network failure.

Network Disconnection (long)

- Objective: Evaluate the local PLC’s ability to manage control independently and the system’s resilience upon reestablishing communication. Compare hydraulic conditions to a failure-free scenario.
- Scenario: The DSC is disconnected from local pumping stations’ PLC for a duration of 120 minutes due to network failure.

Sensor Failure (flow sensor malfunction)

- Objective: Evaluate the DSC’s ability to detect anomalies, switch to fallback operational logic (Auto-Local) and maintain system stability.
- Scenario: De-calibrated, inaccurate readings or malfunctioning flow sensor.

To ensure consistency and reproducibility, each test scenario uses identical rainfall-runoff patterns. The rainfall-runoff from Scenario 3’s first wave was selected for these operational failure tests, as shown in Figure 14.

Figure 14 illustrates the rainfall runoff pattern from Scenario 3 and highlights the intervals when operational failures are introduced. These failures are strategically timed to coincide with the initial rainfall event impacting Station 1, ensuring that all scenarios consistently evaluate disruptions affecting this critical point in the network.

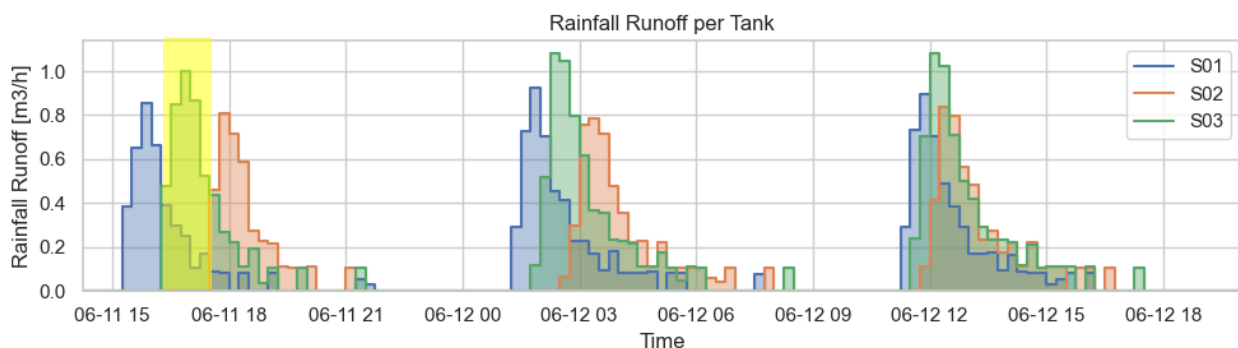

Figure 14: Rain runoffs used from Scenario 3 to evaluate the operational test. Failure indicated with the yellow area.

Network disconnection (short)

Objective

Evaluate the local PLC’s ability to manage control independently and the system’s resilience upon reestablishing communication. Compare hydraulic conditions to a failure-free scenario.

Scenario

In this scenario, we introduce a network disconnection by isolating Station 1 from the DSC. As a result, Station 1 is no longer part of the optimization process performed by the DSC. Essentially, the DSC treats the system as if it were a two-station network, with Station 1 operating offline, unable to communicate with or receive any instructions from the global controller.

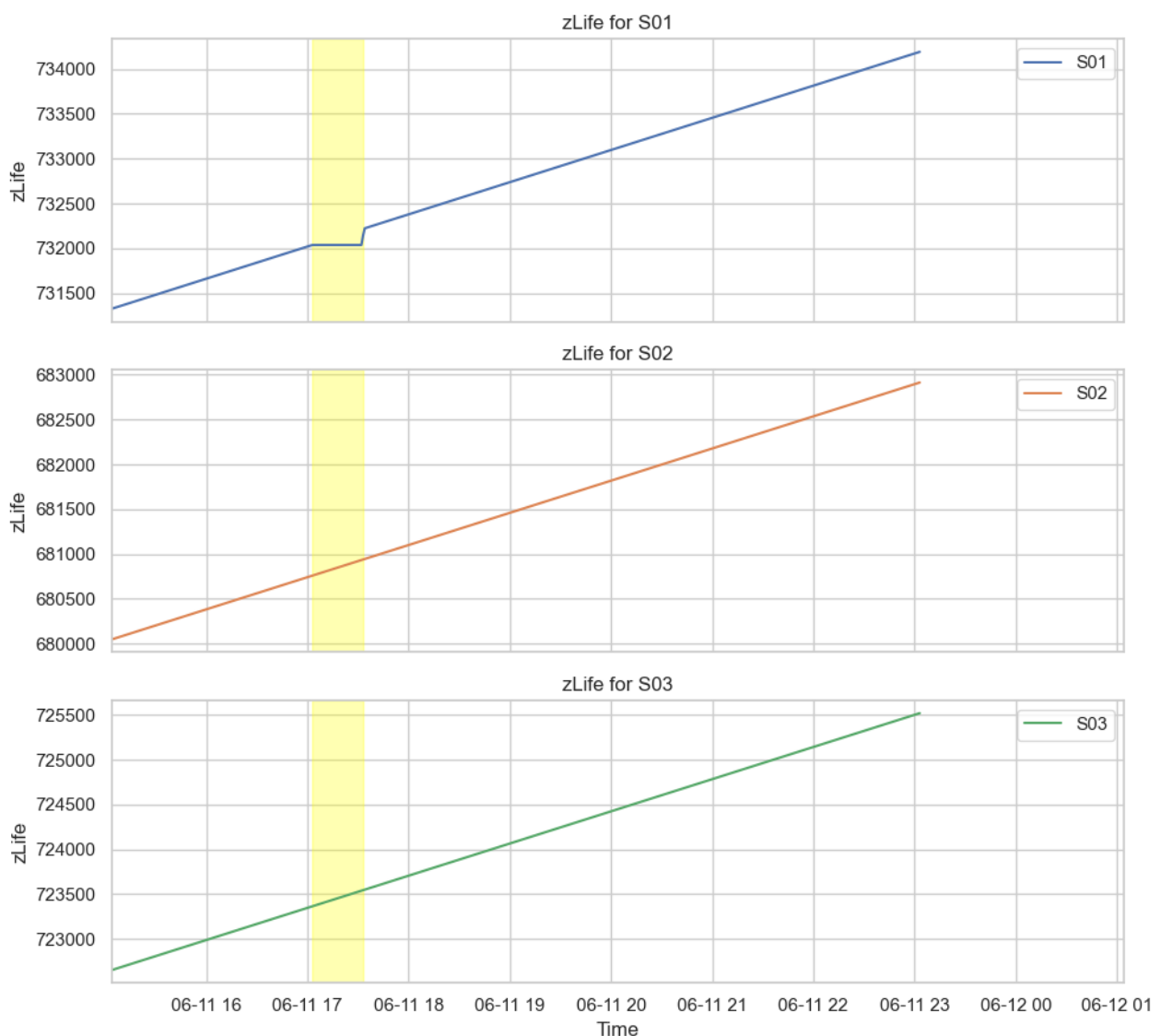

Figure 15: Sequencing number timeout showing network disruption on Station 1, marked with yellow.

- We intentionally disconnected Station 1 from the network for 30 minutes. During this time, Station 1 continued to operate independently.
- Each local station’s PLC sends a heartbeat signal to the DSC and a disruption in communication causes a break in the sequence number. This disruption is illustrated in Figure 15.

performed under the same hydraulic conditions (Scenario 3), which allows for a direct comparison of how volumes evolved at the three stations and how the DSC managed storage utilization.

In a real-world situation, when a station is disconnected, no information is transmitted from the local measurement units. To replicate this in our test, we applied the same principle: when a station is offline, no data is received until it reconnects to the system.

The experiment was conducted with and without network disruption, referred to as “Disconnected” and “Connected” scenarios, respectively. Both tests were

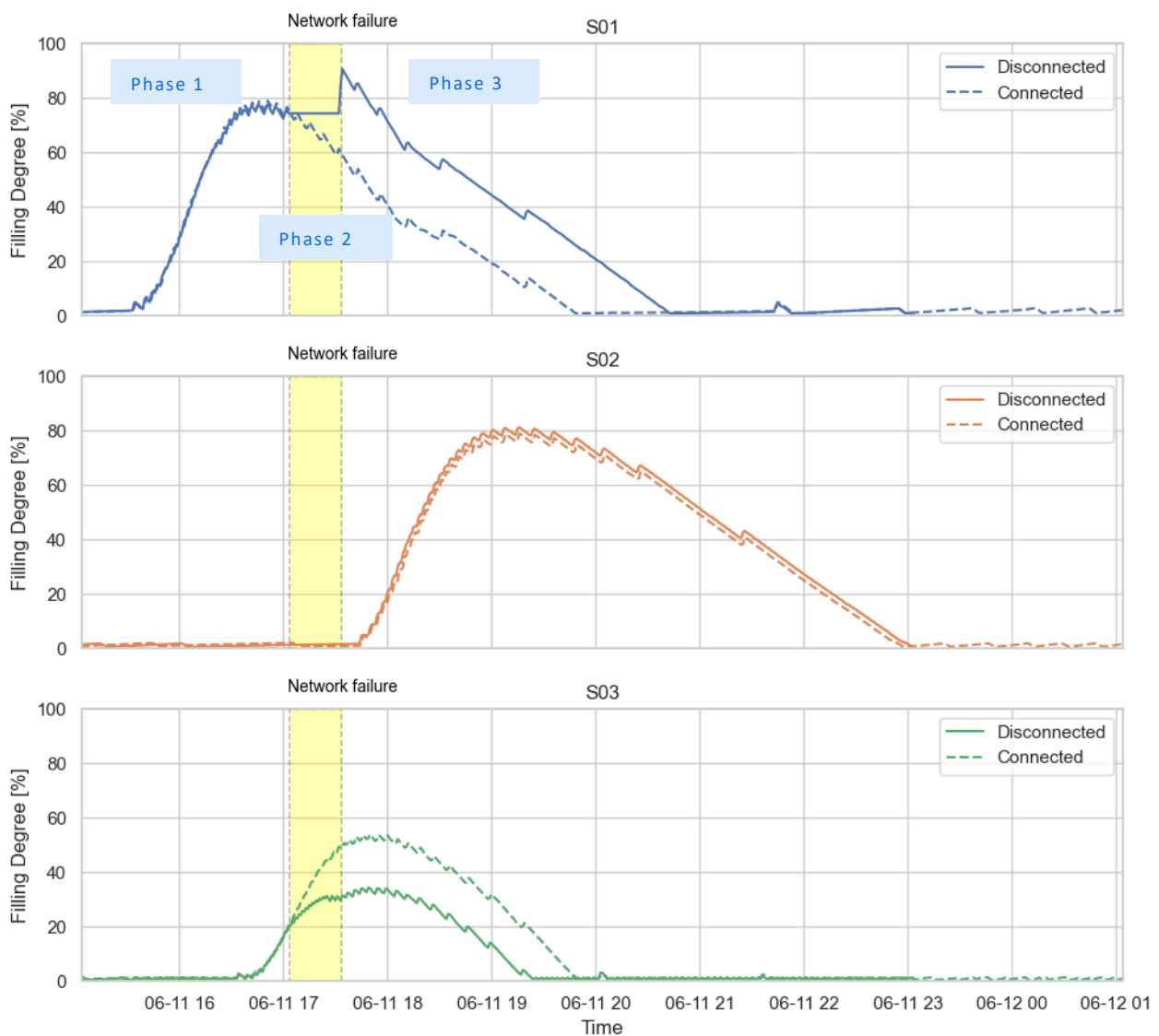

Figure 16: Filling degree evolution before, during and after failure scenario for a connected and disconnected scenario.

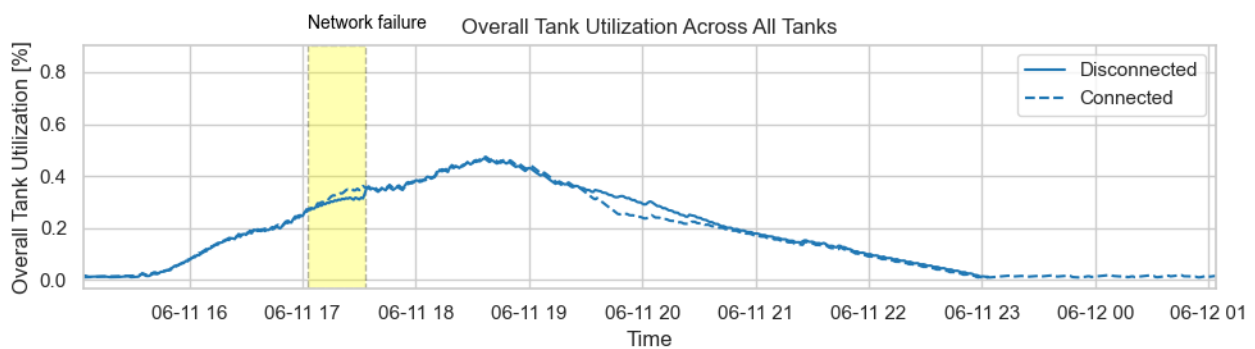

Figure 17: Overall tank utilization for a connected and disconnected test scenario.

Test results and conclusions

To evaluate the impact of the network disruption, we divide the test into three distinct phases:

- Phase 1: Before the failure event – This phase represents normal operation, where all stations are online and data is flowing as expected.
- Phase 2: During the failure event – This phase occurs when Station 1 is disconnected, and no data is transmitted from it to the DSC.
- Phase 3: After the failure event – This phase represents the recovery period when Station 1 comes back online, and the system begins to normalize.

The filling degree of the stations during the short network disruption is illustrated in Figure 16, which shows how the storage levels evolved through these phases. It shows the following results for each phase:

Phase 1: Both the connected and disconnected scenarios are identical, with the DSC operating normally and handling the rainfall event uniformly.

Phase 2: When Station 1 is disconnected, its telemetry signals become unavailable, causing the filling degree data for this station to flatten out due to the lack of new measurements. Despite this disconnection, Station 2 (upstream) and Station 3 (downstream) remain connected to the DSC. Station 2 continues to operate as it would normally, unaffected by the disruption at Station 1. However, Station 3 downstream experiences a decrease in inflow, as Station 1, now offline, is not sending water downstream. Consequently, Station 3 displays a lower filling degree during this phase compared to the fully connected scenario.

Phase 3: When Station 1 reconnects, the filling degree sharply rises, reflecting the accumulation of water at Station 1 due to the disconnection period. The lower filling degree observed at Station 3 in the downstream position indicates that less water was transmitted downstream during the disconnection period. During this recovery phase, Station 1 begins releasing the accumulated volume downstream at a higher rate than under normal connected conditions, as it manages the stored water backlog.

The overall network utilization, depicted in Figure 17 supports these observations. Upon reconnection, the filling degree at Station 1 peaks notably, especially as the rainfall event subsequently impacts Station 2. This behavior underscores that during the disconnection, Station 1 accumulated water volume, reducing downstream flow temporarily. When reconnected, Station 1 temporarily experiences higher filling degrees compared to the continuously connected scenario, due to the additional stored water being released downstream.

Figure 17 clearly illustrates the differences in overall tank utilization between connected and disconnected scenarios, highlighting the impact of temporary disconnection on network performance and station filling degrees.

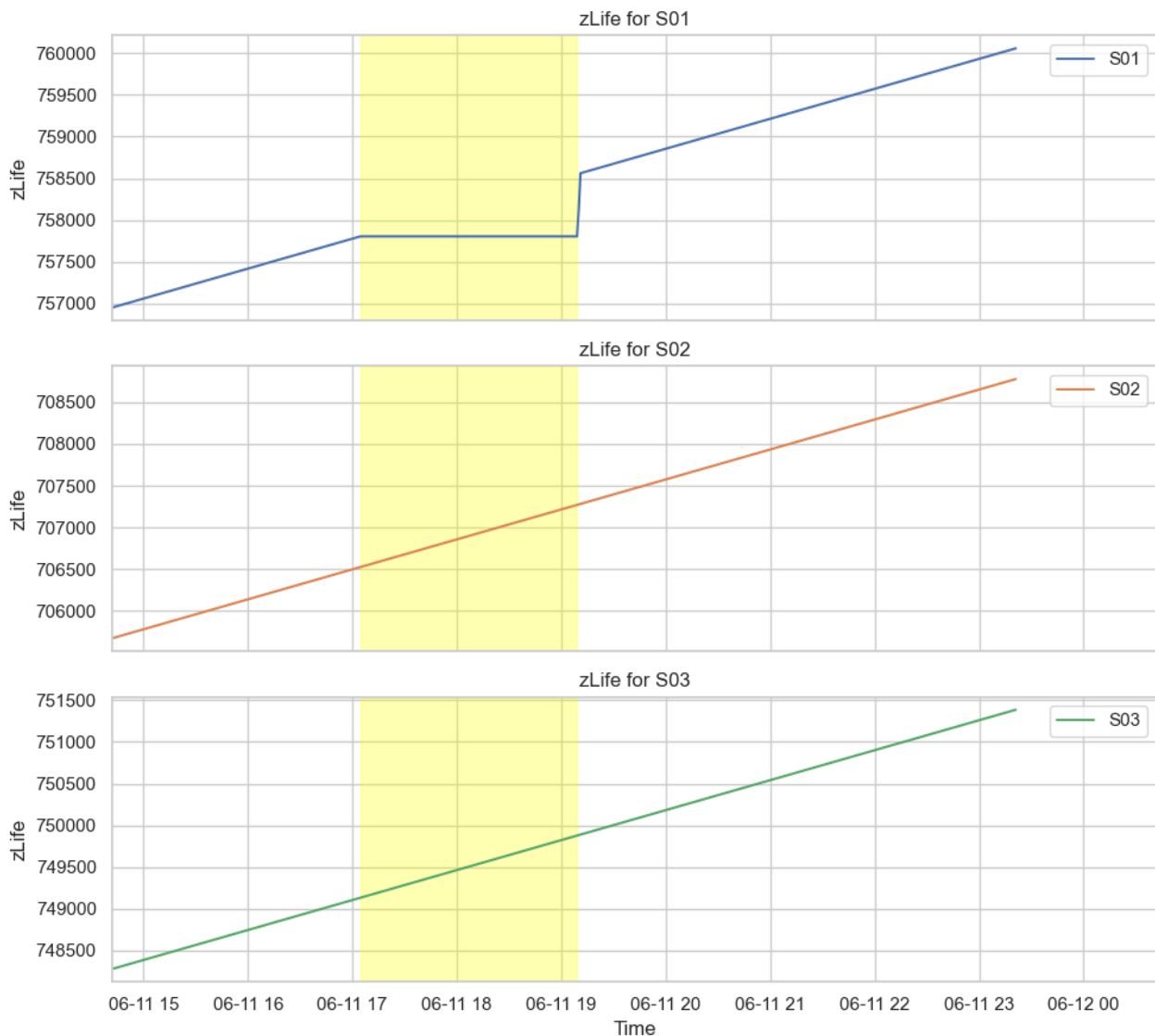

Figure 18: Sequencing number timeout showing network disruption on Station 1, marked with yellow.

Network disconnection (long)

Objective

Evaluate the local PLC’s ability to manage control independently and the system’s resilience upon reestablishing communication. Compare hydraulic conditions to a failure-free scenario.

Scenario

Like the previous short-duration test, we intentionally disconnected Station 1 from the network at the same

rainfall-runoff point, but this time the disconnection lasted for 2 hours. During this period, Station 1 operated independently in a fallback mode, unable to send or receive data from the DSC. This disruption is evident in the sequencing number shown in Figure 18.

Test results and conclusions

We evaluate the effects of this prolonged disconnection by examining how volumes evolved within the stations and how the DSC handled the operational disruption. As with the short-duration

scenario, no telemetry data was available from Station 1 during the disconnection period.

The evolution of the filling degree in each station before, during and after the network disruption is illustrated in Figure 19 below.

The conclusions from this test are the following:

Phase 1: During this initial phase, the system functions normally. The connected and disconnected scenarios

are identical, with the DSC managing the rainfall-runoff in the same manner.

Phase 2: Once Station 1 becomes disconnected, it enters an independent fallback operational mode, significantly restricting its outflow. Consequently, the outflow from Station 1 is minimal, causing its tank to accumulate water continuously, eventually reaching a filling degree of 100% by the time connectivity is restored.

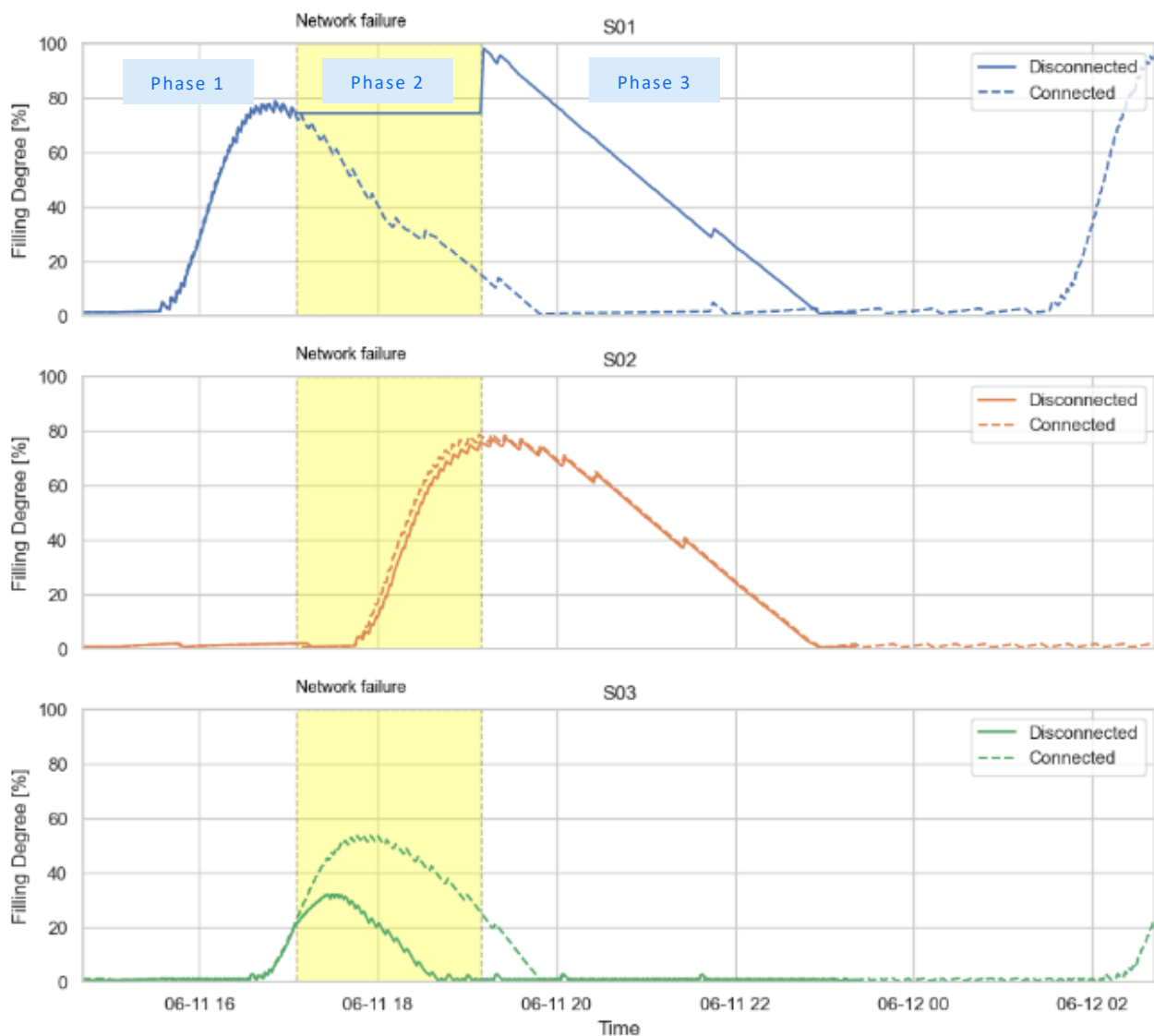

Figure 19: Filling degree evolution before, during and after failure scenario for a connected and disconnected scenario

Due to Station 1's restricted outflow, Station 3 (downstream) receives considerably less water than usual during this period. This results in Station 3 exhibiting lower filling levels and a faster rate of emptying compared to the fully connected scenario.

Station 2 (upstream), aware that Station 1 is in fallback mode, automatically adjusts its outflow to a lower maintenance level. This adjustment ensures the network constraints are respected, preventing any unintended overflow downstream. Thus, Station 2 also accumulates water, though to a lesser extent compared to Station 1.

Phase 3: When Station 1 reconnects, the system experiences an immediate shift. The stored water from Station 1 begins flowing downstream again at a significantly increased rate, as the tank attempts to empty the accumulated volume as quickly as possible, in coordination with Station 2.

Since the combined maintenance outflows of Stations 1 and 2 remain lower than the maximum outflow capacity of Station 3, Station 3 comfortably manages the increased inflow without additional filling. Furthermore, since the rainfall event has already passed by this point, Station 3 has ample capacity to manage and evacuate incoming volumes without risk of overflow, even keeping the filling degree at an almost-empty level.

The overall network utilization, depicted in Figure 20, supports these observations.

While the filling degree data during the disconnected period does not reflect the actual volumes due to the flattening out of Station 1's telemetry signals, it is clearly observable that once communication is restored, there is a distinct shift in volume distribution. Specifically, the accumulated water stored during the disconnection is released downstream after the rain events have passed, resulting in an increased filling degree approximately 10-15% higher than observed under normal connected conditions. This demonstrates that temporary disconnections lead to delayed volume release and subsequent higher utilization levels post-event.

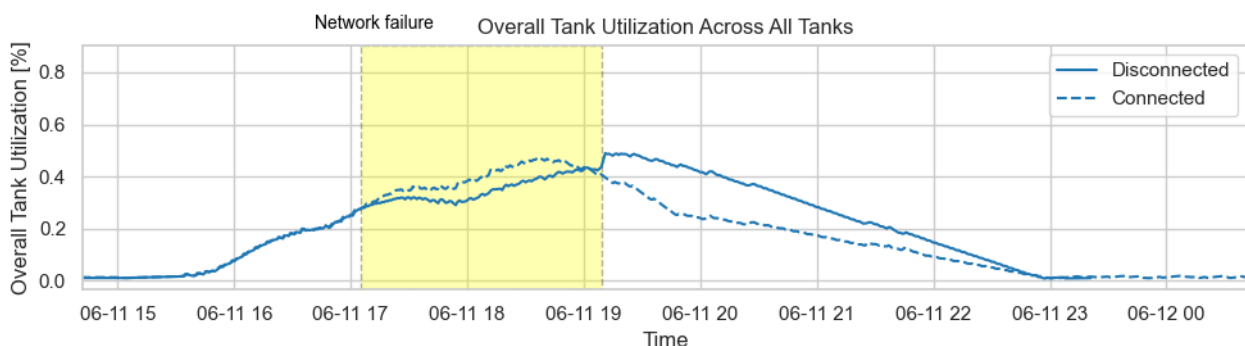

Figure 20: Overall tank utilization for a connected and disconnected test scenario.

Sensor failure (flow sensor malfunction)

Objective

Evaluate the DSC’s ability to detect anomalies, switch to fallback operational logic (Auto-Local) and maintain system stability.

Scenario

In this test, we introduce a flow sensor failure scenario by mimicking a disconnection of the flow sensor at Station 1 for 2 hours. The test begins after the first

rain event has concluded, allowing us to then introduce a fallback behavior by switching the station to "Maintenance" mode. This mimics a real-world situation where a local controller, upon detecting a sensor failure, would enter maintenance mode and trigger an alert. In this mode, an operator would be required to manually set the pump speed, as flow control becomes impossible without the sensor’s data.

This behavior is clearly illustrated in Figure 21, where the DSC state variable shows the status of the local PLCs. State 6 indicates that the system is under the

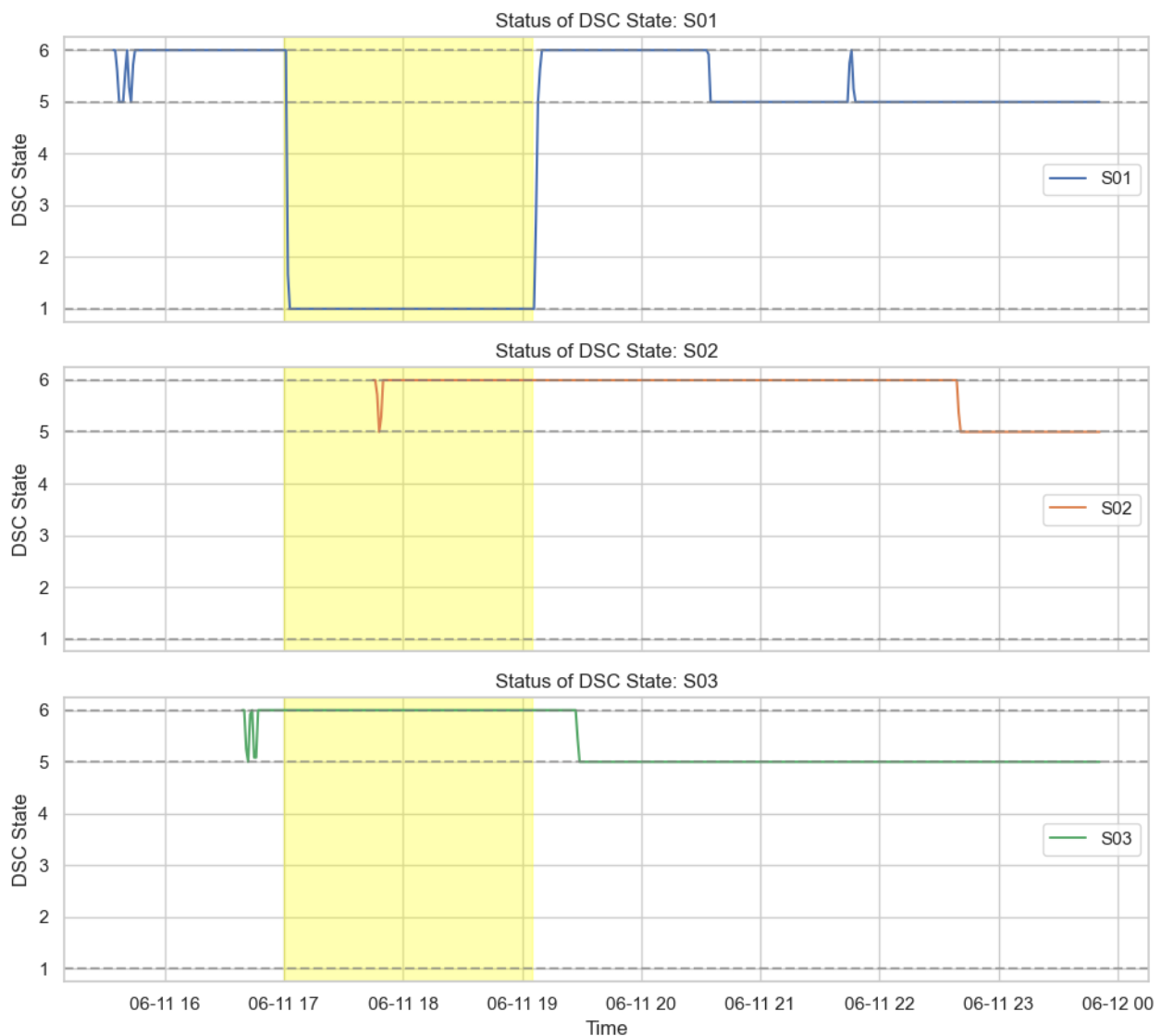

Figure 21: States of the local DSC state machine for each PLC corresponding to the pumping stations.

DSC, State 5 indicates the system is DSC-controllable and State 1 represents the Maintenance mode. When a flow sensor failure occurs, the DSC automatically switches to Maintenance mode to allow for manual intervention and adjustments (see the yellow shaded area.)

Test results and conclusions

The outflows from the tanks during the flow sensor failure scenario are illustrated in Figure 22. The figure shows how the flow adjustments were made manually

in Maintenance mode and how the system behaved during the fallback operation.

When Station 1 is in Maintenance mode, the outflow is managed manually, leading to the observed changes in flow distribution across the stations. The graph shows how the outflow from Station 1 and its downstream impact on Station 2 and Station 3 evolve over time.

The conclusions from this test regarding the pump flows are as follows.

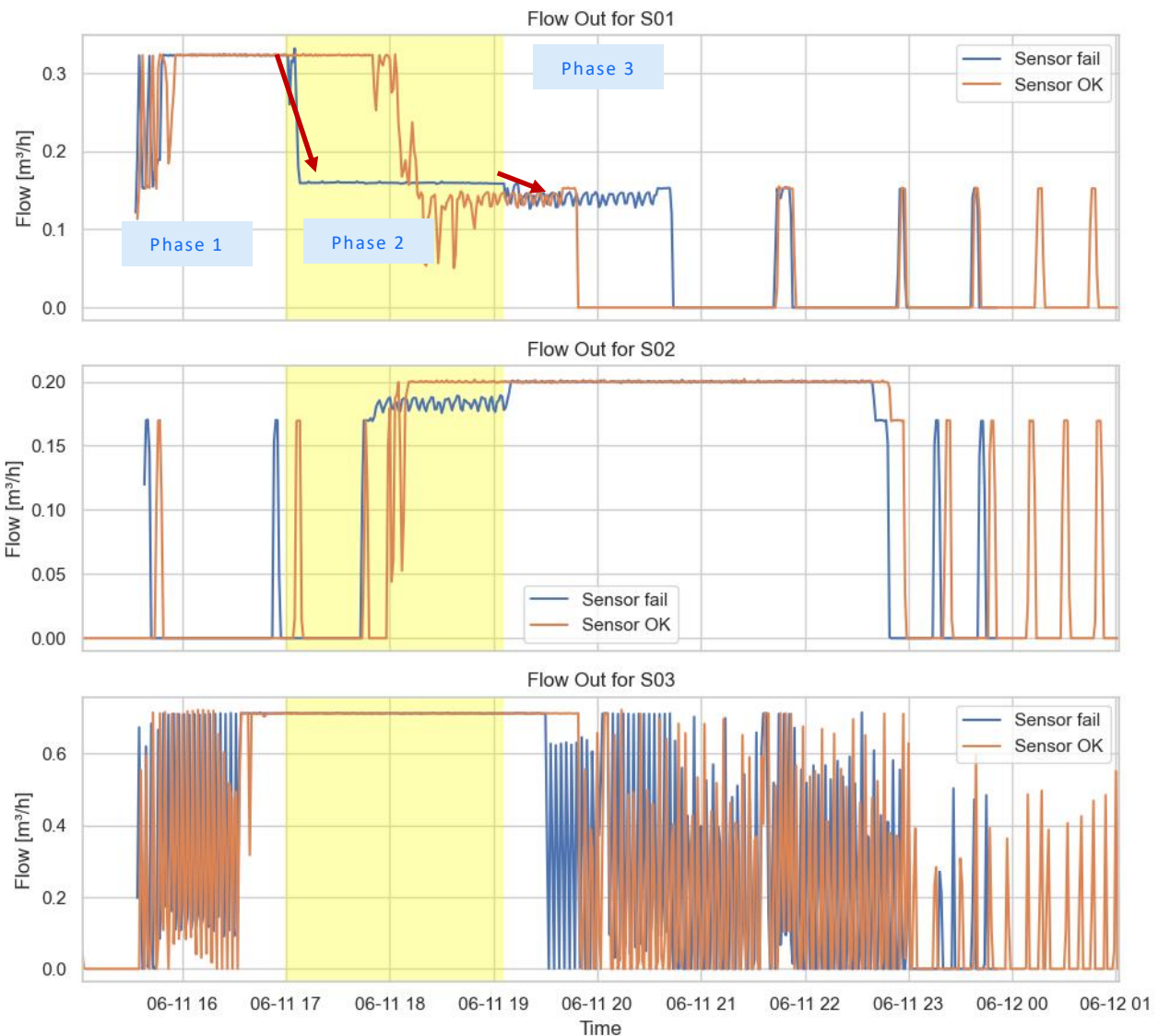

Figure 22: Measured pump flow comparison for a flow sensor failure scenario at the local pumping stations.

Phase 1: Prior to the sensor failure, the system operates normally, with Station 1 under the DSC. Automated control of the pumps is functioning as expected, with no disruptions in the flow management.

Phase 2: At the start of this phase, Station 1 is switched to "Maintenance" mode and the main pump speed is manually set to 60-61%. Since no automated control is available in Maintenance mode, the pump speed for the side pump is manually set to 45% to assist with evacuating the side-storage towards the column. These manual adjustments are essential for

maintaining control over the flow during this fallback operation.

Approximately 4 minutes into this phase (after two cycles), the main pump speed is reduced to 43%, with further adjustments to 37% to stabilize the flow rate at around 0.15 m³/h. This setup remains unchanged during the remainder of the failure event until Station 1 is switched back to "DSC-Ready" mode.

Phase 3: Once Station 1 is restored to "DSC-Ready" mode, the system returns to automatic control and the flow adjustments made manually in Phase 2 are no

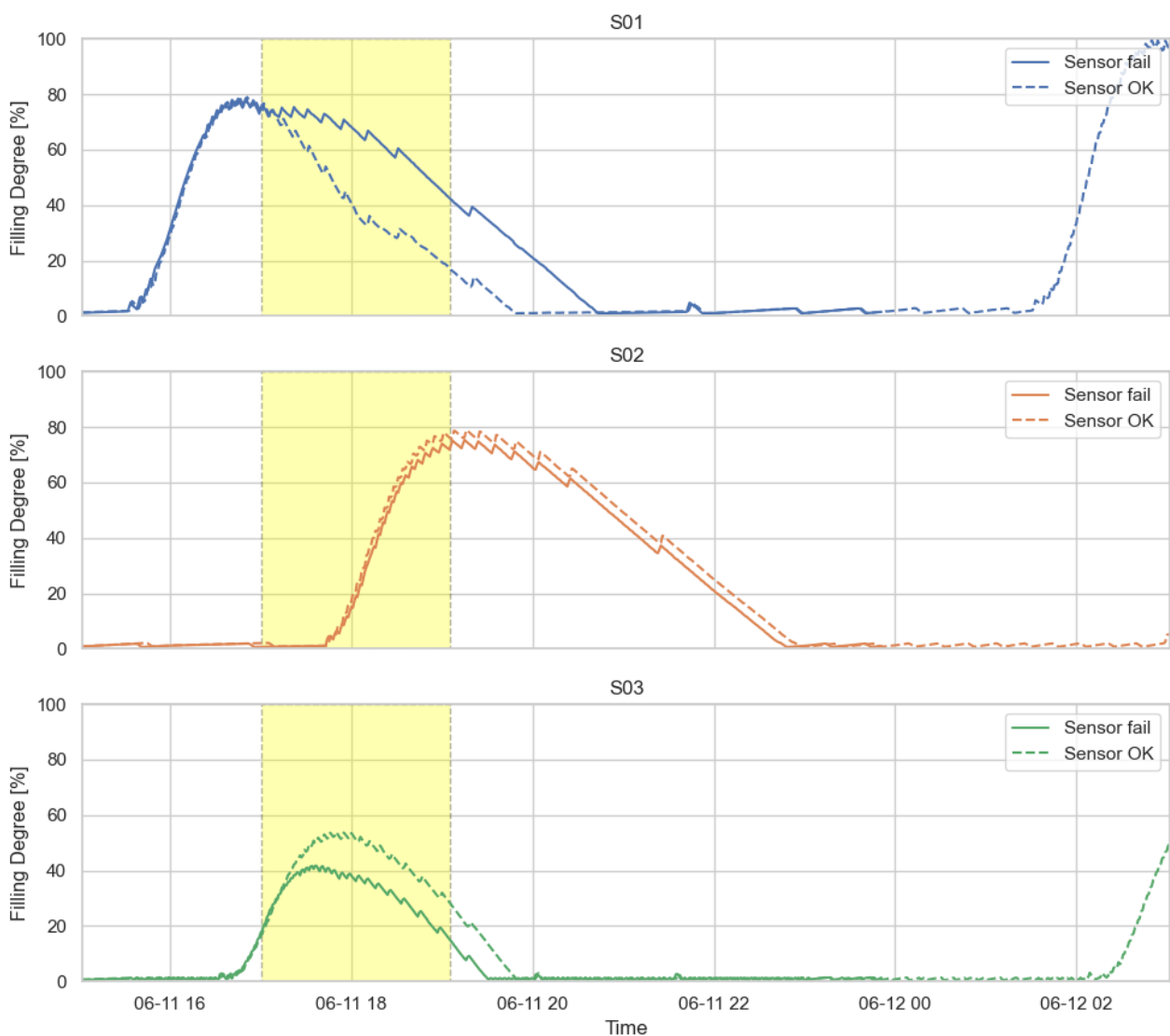

Figure 23: Filling degree evolution before, during and after a sensor failure scenario.

longer needed. The system resumes normal operation and the first rain event concludes by the end of this phase.

Similar to the network disconnection scenario, when the flow sensor at Station 1 fails and the station switches to maintenance mode, volume begins to accumulate at the upstream station. This accumulation leads to a reduced load on the downstream station (Station 3), allowing it to effectively handle the remaining inflow once all rain events have peaked and passed.

Conclusion

The results show that the DSC is able to handle simulated real-life operational conditions such as short- and long-term network disconnections, as well as sensor failures, with the following results:

- Operations with short IT-network disconnection
Maintains effective storage management
- Operations with long IT-network disconnection
Demonstrates robust fallback mechanisms
- Sensor failure test System remains stable and recovers seamlessly

It is concluded that the DSC is both able to optimize the network, as well as mitigate for suboptimal operational challenges to ensure that sewer operations continue despite downtimes/sensor failures. It is important to note that maintenance and upkeep of the network and assets like sensors is important, so that the system's utilization can continue to be efficient with the DSC. These tests are to demonstrate that the DSC can handle realistic operating conditions, where its efficacy is tied to its ability to use functional assets to optimize utilization of existing network capacity.

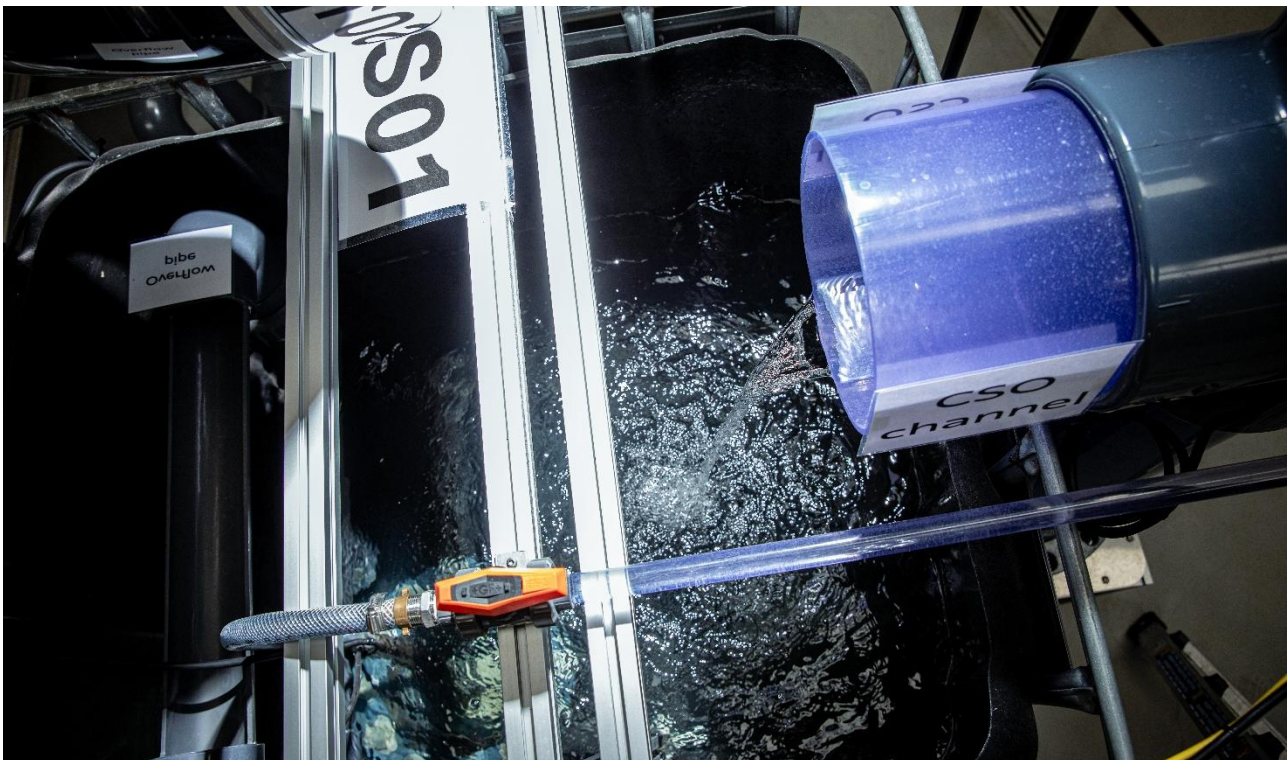

Grundfos Holding A/S
Poul Due Jensens Vej 7
DK-8850 Bjerringbro
Tel: +45 87 50 14 00
www.grundfos.com

GRUNDFOS 

Possibility in every drop