

SCALA2

Pressure boosting. Perfected.

With the new generation **SCALA2**, we unveil the next era of integrated booster solutions, featuring pioneering technology that delivers constant water pressure, low noise, and energy efficiency.

The Grundfos SCALA2 is an innovative, all-in-one pressure boosting solution that provides reliable operations in homes and apartments with up to 3 floors and 8 different taps.

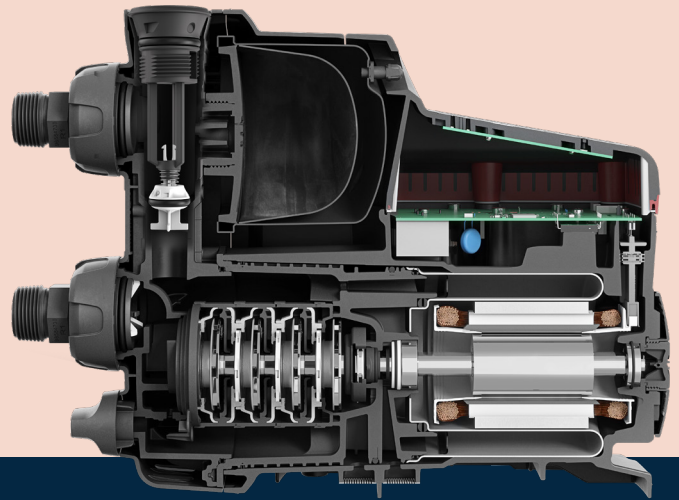

Your benefits



Hassle-free installation

Built for hassle-free installation right out of the box — no need for additional components or complex tools.



Simple selection

With only one product variant and size for all domestic applications, it's easy to keep one in the van or at the company warehouse.



Compact all-in-one booster

Fully integrated water pressure booster in a compact and robust design minimizes space limitations.



Product support

Grundfos provides strong product support to ensure you gain a comprehensive understanding of the new SCALA2. Our support includes online installation and training videos, along with comprehensive technical documentation.

Benefits for homeowners



Constant pressure in up to 8 taps in the home

With integrated control features and a frequency-driven motor, the pump delivers perfect water pressure to all taps, automatically adapting to your customer's water consumption habits.



The quietest pressure booster in the market

Thanks to its upgraded hydraulic cover, the new SCALA2 achieves optimal water pressure with a noise level as low as 44 dB(A). Compared to common household appliances, the noise level is equivalent to a quiet dishwasher.



World-class energy performance

Equipped with improved hydraulics, a permanent magnet motor, and speed control, the SCALA2 outperforms many other domestic water pressure boosters in the market. It operates only when needed, automatically adapts to water consumption habits, and uses the right amount of energy to maintain pressure as efficiently as possible.

grundfos.to/SCALA2Install

GRUNDFOS

Possibility in every drop

A booster pump for all installation types

SCALA2 uses groundbreaking technology to integrate essential pressure-boosting components into a single compact enclosure. Other key features make it versatile for various installations:

City mains*

The variable-speed motor, in combination with smart controls, provides optimal water pressure to all taps, regardless of inlet pressure fluctuations, and it is rated for up to 145 PSI.

Tank or shallow well

Self-priming, de-air function, and dry-run protection guarantee a steady water supply from shallow wells or underground tanks.

Roof tank

The pump ensures precise control and setpoint adjustment for optimal water pressure when boosting from a tank. Its IPx4D rating allows for both indoor and outdoor installation.

** Note: Some local regulations might impose limitation to the installation. Please make sure to follow local rules and regulations.*

Accessories

Inlet filter

Prevents harmful particles from reaching the system. Connection 1" NPT.



Performance curve

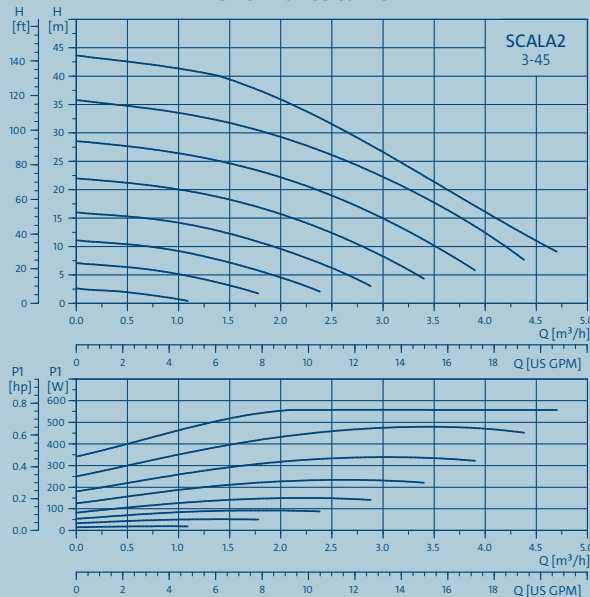

Technical details

SCALA2

Noise	44 dB(A)
Max. ambient temperature	131° F
Max. liquid temperature	113° F
Max. system pressure	145 psi
Max inlet pressure	87 psi
Max head	147 ft.
IP rating	X4D (outdoor installation)
Floors	Max. 3
Taps	Max. 8
Power input P1	550 W
Rated power P2	450 W
Dimensions	H: 11.9 inch L: 15.9 inch W: 7.6 inch
Weight	21.3 lb
Approvals for drinking water	NSF61 & NSF372



Learn more and see all details
at grundfos.to/SCALA2Install