

COMFORT

Circulator pumps
50/60 Hz



1. Product description	3	7. Product numbers	29
Type key	3	COMFORT, International, DACH, GB, CN, RU, 50/60 Hz	29
Approvals	3	COMFORT, USA, 50/60 Hz	30
Applications	4		
Performance range	5		
2. Operating conditions	6	8. Accessories	31
Pumped liquids	6	Fittings	31
Temperatures	6	Spare parts	32
Pressures	6		
Pump location	6	9. Grundfos Product Center	33
3. Functions	7		
COMFORT with AUTOADAPT	7		
Temperature control mode for temperature control (T) variants	9		
COMFORT with digital timer	10		
4. Construction	11		
Electrical insulation	11		
Motor	11		
Stator	11		
Spherical separator	11		
Bearing pin and bearing ball	11		
Rotor	11		
Pump housing	12		
Isolating valve and non-return valve	12		
Seal ring	12		
Union nut	12		
Sectional drawing	13		
Material specification	13		
5. Performance curves	14		
Curve conditions	14		
6. Data sheets	15		
COMFORT 15-14 B PM, 15-14 B PM DACH, 15-14 B PM CN	15		
COMFORT 15-14 BA PM, 15-14 BA PM DACH, 15-14 BA PM CN	16		
COMFORT 15-14 BDT PM, 15-14 BU PM DACH, 15-14 BDT PM CN	17		
COMFORT 15-14 BX PM, COMFORT 15-14 BX PM DACH	18		
COMFORT 15-14 BXA PM, 15-14 BXA PM DACH	19		
COMFORT 15-14 BXDT PM, 15-14 BXU PM DACH	20		
COMFORT 15-14 B PM GB	21		
COMFORT 15-14 BA PM GB	22		
COMFORT 15-14 MB PM DACH	23		
COMFORT 10-16 T PM BU/LC	24		
COMFORT 10-16 DT PM BU/LC	25		
COMFORT 10-16 A PM B5/LC	26		
COMFORT 10-16 A PM BN5/LC	27		
COMFORT 10-16 A PM BU/LC	28		

1. Product description

Type key

Outside USA

Example: COMFORT 15-14 BXU PM DACH

Code	Explanation	Designation
COMFORT 15-14		Pump type
B	Brass pump housing	Options
M	Motor (pump head only)	
X	Integrated isolating valve and non-return valve Length 140 mm / G 1	
DT	Digital Timer	Features
U	Digital Uhr (DACH only)	
A	AUTO _{ADAPT}	
PM	Permanent magnet	
.	International	
GB	Great Britain	Country
DACH	Germany, Austria, Switzerland	
CN	China	

USA

Example: COMFORT 10-16 DT PM BU/LC

Code	Explanation	Designation
COMFORT 10-16		Pump type
.	Basic	
T	Temperature control	Features
A	AUTO _{ADAPT}	
DT	Digital Timer	
PM	Permanent magnet	-
B5	1/2" internal sweat, Brass	
BN5	1/2" NPT, Brass	Connection
BU	1 1/4" NPSM with integrated isolating valve and non- return valve, Brass	
LC	Line cord	-

Approvals



European approvals



US approvals

VDE-GS_APPROVALS_SMALL

CLASSIFIED-LISTED-UL_SMALL

Applications

Grundfos COMFORT circulator pumps are designed for the following:

- domestic hot-water systems in single- and two-family houses
- small heating systems
- cooling and air-conditioning systems.

The pumps are suitable for open and closed systems. They must be installed indoors.

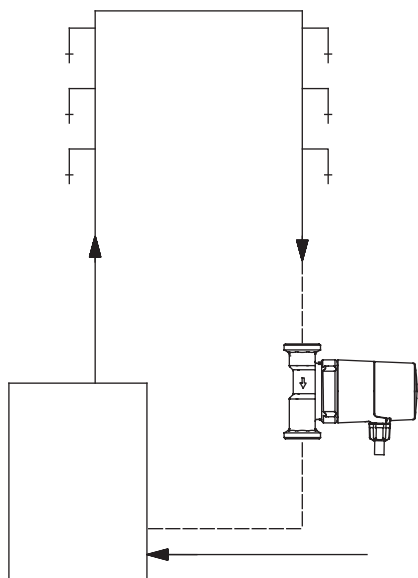

Single-loop system

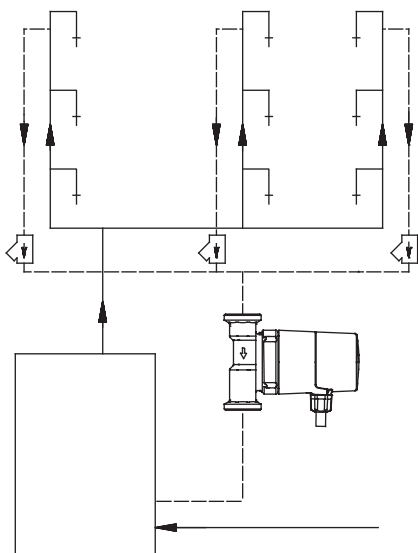

Branched system

Domestic hot-water systems

For circulation of drinking water in domestic hot-water systems, we recommend to use Grundfos COMFORT types with brass pump housing in systems with hot-water storage tanks.

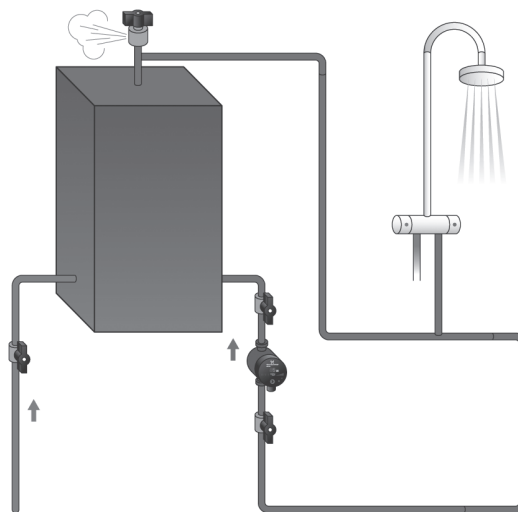

Domestic hot-water system with hot-water storage tank

TM019110

TM019111

TM059316

Performance range

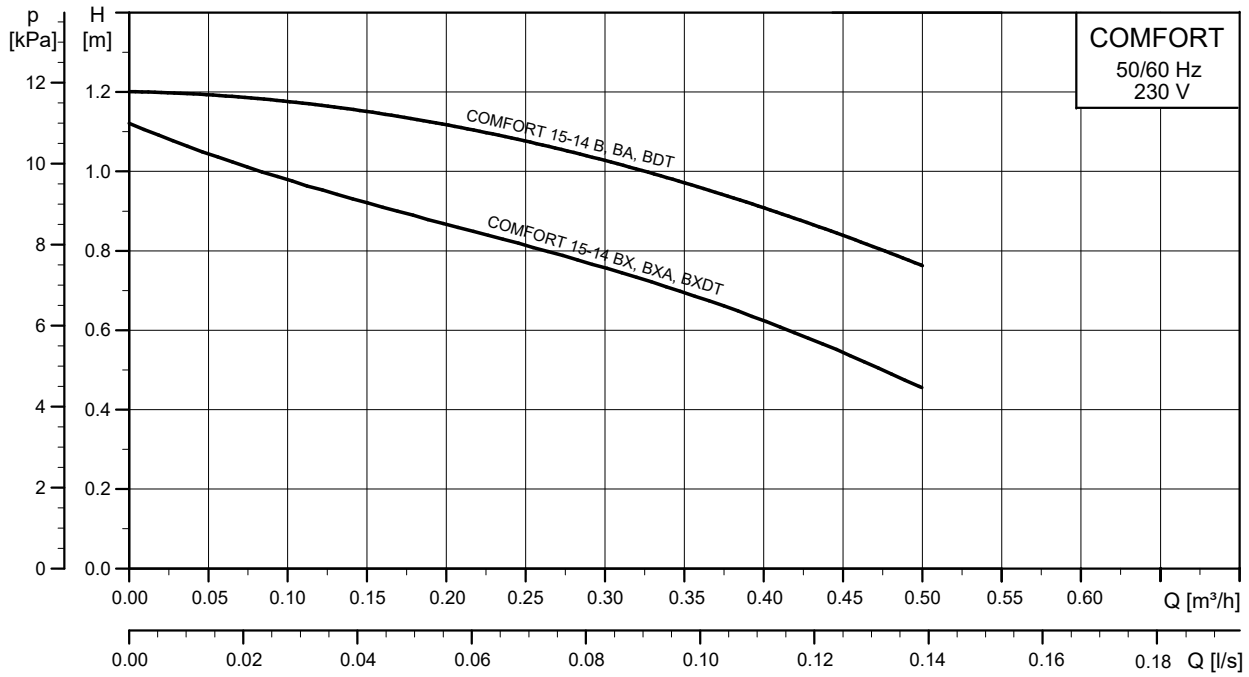

TM068755

COMFORT performance range (outside USA)

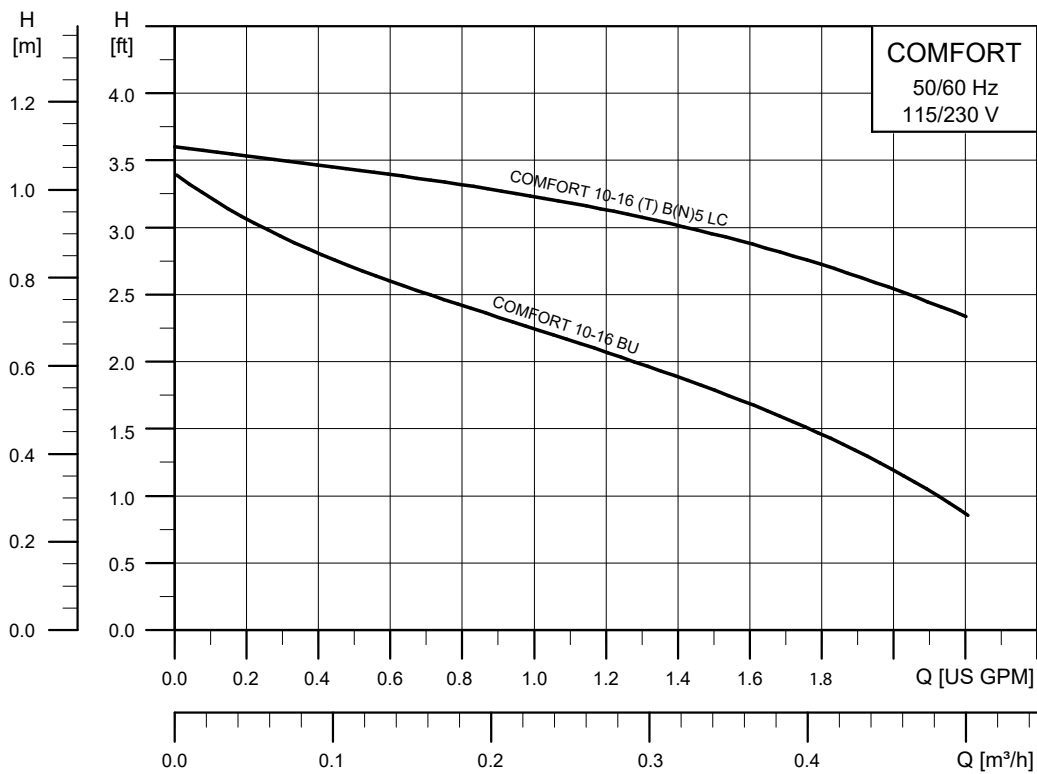

TM068411

COMFORT performance range USA

2. Operating conditions

Pumped liquids

- Thin, clean, non-aggressive and non-explosive liquids without solid particles or fibres
- Cooling liquids, not containing mineral oil
- Domestic hot water
- Softened water.

The kinematic viscosity of water is 1 mm²/s (1 cSt) at 20 °C (68 °F). If the pump is used for a liquid with a higher viscosity, the hydraulic performance of the pump will be reduced.

Example: 50 % glycol at 20 °C (68 °F) means a viscosity of approximately 10 mm²/s (10 cSt), reducing pump performance by approximately 15 %.

When selecting a pump, the viscosity of the pumped liquid must be taken into account.

Temperatures

Liquid temperature

Liquid temperature range: 2 to 95 °C (36 to 203 °F).

Operating temperature

We recommend that you keep the operating temperature around 50 °C (122 °F) to minimise buildup of lime deposits. Be aware of the risk of legionella contamination.

Ambient temperature

The ambient temperature must always be lower than the liquid temperature to minimise condensation in the stator housing, and not exceed 40 °C (104 °F).

Pressures

System pressure

Maximum system pressure (PN 10): 1.0 MPa (10 bar/145 psi).

Inlet pressure

To prevent cavitation noise and damage to the pump bearing, a minimum inlet pressure of 0.5 bar (7.3 psi) (5 m head) is required at the pump inlet port.

Pump location

Indoors, in a non-aggressive and non-explosive atmosphere.

Relative humidity: Maximum 95 %.

3. Functions

COMFORT with AUTO_{ADAPT}

COMFORT BA PM and BXA PM models have the following operation modes:

- AUTO_{ADAPT} mode
- temperature control mode
- continuous 100 % mode.

AUTO_{ADAPT} mode

The AUTO_{ADAPT} function adapts the operating hours by switching on and off according to the tapping pattern of the users. This means that the pump provides maximum comfort and saves energy at the same time.

Energy-saving

The AUTO_{ADAPT} function saves energy in two ways:

- Electrical energy consumption of the pump
- Heat energy consumption of the domestic hot-water system.

The AUTO_{ADAPT} function automatically adjusts the number of operating hours, based on the hot-water consumption in the given system.

The AUTO_{ADAPT} function requires a temperature sensor to be installed on the flow pipe 20 to 50 cm from the boiler outlet. This sensor and the temperature sensor incorporated in the pump detect when hot water is tapped. The detected tapping events are logged and used to predict the consumption pattern. The AUTO_{ADAPT} function automatically controls the on/off behaviour of the pump according to this pattern. This ensures that the pump only runs when necessary, which saves both heat energy and electrical energy.

The pump needs two weeks to adapt when hot water is tapped. This means that the pump starts up in temperature mode the first two weeks even if you have selected AUTO_{ADAPT}.

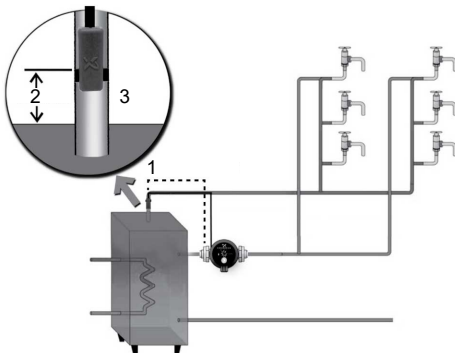

COMFORT BA PM or BXA PM pump with built-in temperature sensor

Pos.	Description
1	Max. 2.5 m(8 ft)
2	20-50 cm
3	(8-20 inches)

AUTO_{ADAPT} in heating systems regulated with a thermostatic regulating valve

In systems including a thermostatic regulating valve, choose a COMFORT pump without the AUTO_{ADAPT} function.

Choosing a pump with AUTO_{ADAPT} function will result in two active regulating systems working separately, which is not recommendable.

NOTE: If a pump with AUTO_{ADAPT} function is installed in a circulation system where the temperature of the recirculated water is regulated by a thermostatic regulating valve, we recommend that you open the thermostatic regulating valve completely. This is done by setting the valve to max., which deactivates its regulating function.

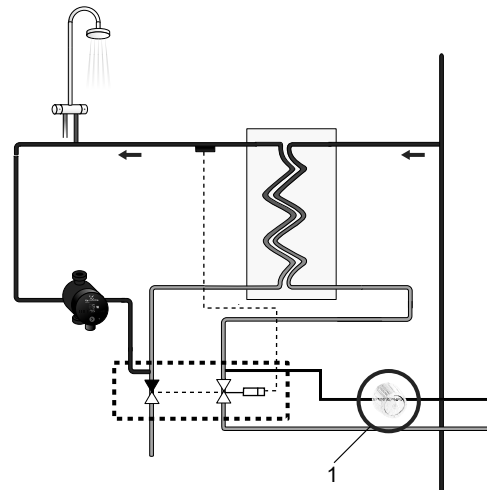

TM057942-GREY

Example of an application with thermostatic regulating valve

Pos.	Description
1	Thermostatic valve

Control function

The control function is a combination of three parameters:

- detection of hot-water consumption
- event log function (when the demand occurs)
- pump control.

Detection of hot-water consumption

The detection of hot-water consumption is done via the temperature sensor installed in the flow pipe. The system logs the tapping events. Temperature rise caused by the pump operation is not registered in the event log.

TM049359

Event log function

The AUTO_{ADAPT} function incorporates an event log that learns the scheme of demand for hot water in the domestic hot-water system. Via the event log, the pump predicts when to start circulating hot water.

The event log function stores the weekly tapping events in the system. The hot-water consumption pattern for two weeks is stored in the event log. See example.

Date	Time of day															
	00:00	00:20	00:20	00:40	----->	07:00	07:20	07:20	07:40	07:40	08:00	08:00	08:20	----->	23:30	23:50
01	0		0			0		T		0		0				0
02	0		0			0		T		T		0				0
03	0		0			0		T		0		0				0
04	0		0			0		T		0		0				0
05	0		0			0		0		T		0				T
06	0		0			0		T		0		0				0
07	0		0			0		T		0		0				0

0: No consumption.

T: Tapping event is registered.

Example

- From 07:20 to 07:40, six tapping events (T) are registered (morning bath).
- From 07:40 to 08:00, two tapping events (T) are registered.
- From 23:30 to 23:45, one tapping event (T) is registered.

This pattern implies that hot water should be available for tapping from 07:20 to 08:00.

At 08:00 the pump can stop circulating hot water. Likewise, the pump should circulate hot water for use from 23:30 to 23:50.

The data shown is for one week of operation only. The pump stores data for two weeks. When data for two weeks has been logged, the pump is able to distinguish between the tapping pattern during workdays and weekends.

Pump control

Pump operation is based on the data stored in the event log and on the temperature of the pipes.

The pump control incorporates a temperature hysteresis, meaning that the pump ensures that the hot-water temperature is within the range of what is accepted as hot water. This temperature hysteresis control is enabled when the data content of the event log makes it probable that hot water will be tapped within the next 20 minutes.

In the example, the hysteresis control will start at 07:00 and run continuously until 08:00.

Disinfection and flushing

Once a week a disinfection function is run for 15 minutes. If, at another time of the week, a higher temperature is measured, the disinfection run will be shifted to this time. If the pump is switched off for eight hours, it will be on to do a flushing of the circulation pipe with a duration of 15 minutes.

Fault indication

Defective external temperature sensor

If in AUTO_{ADAPT}, the red error indicator LED is on and goes off when the pump is switched manually to temperature control mode, the external temperature sensor is defective. In this case, the pump turns internally to temperature control mode because the external temperature sensor is needed for the AUTO_{ADAPT} control mode. The display does not automatically change to temperature control mode.

Defective internal temperature sensor

If in AUTO_{ADAPT}, the red error indicator is on and does not go off when the pump is switched manually to temperature control mode, the internal temperature sensor is defective. In this case, the pump uses the external temperature sensor for the temperature control mode.

Temperature control mode for AUTO_{ADAPT} (BA, BXA) variants

The regulation of the COMFORT AUTO_{ADAPT} models is based on temperature control. The operating range of the pump is kept within a calculated temperature range. This means that the pump operates in an average temperature area providing the maximum comfort and saves energy at the same time.

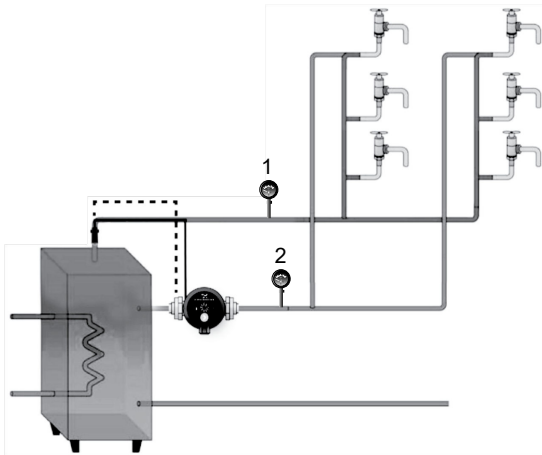

TM060947

COMFORT in heat application

Pos.	Description
1	T_{supply}
2	T_{return}

With temperature control, the maximum temperature measured at both sensors is stored and the pump automatically calculates the gap between T_{stop} and T_{start} . The pump switches on when one of the sensors detects a lower temperature than T_{start} . The pump switches off when the T_{stop} temperature is exceeded on both sensors.

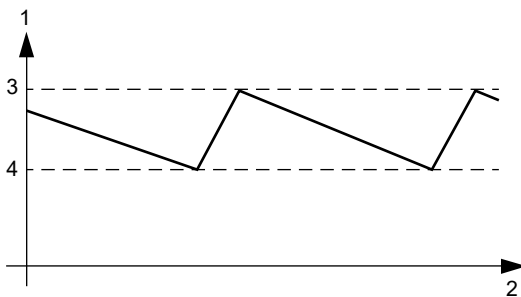

TM060948

Temperature control mode

Pos.	Description
1	T_{supply}
2	Time
3	T_{stop}
4	T_{start}

Continuous 100 % mode

The pump is running continuously at full speed without any control.

Temperature control mode for temperature control (T) variants

The COMFORT T PM variant has an integrated temperature control mode that controls the circulation. The temperature control mode switches the pump off when a preset temperature limit T_{off} is reached, and back on when a preset temperature limit T_{on} is reached.

These temperature limits are set automatically and dynamically. Manual settings are not needed.

After the first installation or after a power cut-off, the pump carries out an identification run for 10 minutes to verify the system temperature. Based on the result, T_{on} and T_{off} are calculated. The identification run is repeated every 12 hours to avoid a wrong temperature setting, for example during night setback of the water heater.

- $T_{on} = T_{sys} - 14\text{ °C}$ (57 °F)
- $T_{off} = T_{sys} - 7\text{ °C}$ (44 °F)

COMFORT with digital timer

COMFORT BDT and BXDT PM models have the following functions and operating modes:

- Continuous 100 % mode. Set the pump to run in continuous 100 % mode with no defined operating periods.
- Digital timer. Use the default operating schedule or customise the pump's operating periods.

Continuous 100 % mode

The pump is running continuously at full speed without any control.

Digital timer

COMFORT BDT and BXDT PM models have an integrated digital timer. With the timer function you can customise the pump's operating periods ensuring optimal comfort while lowering energy costs.

The timer includes default operating periods:

- from 6:00 to 9:00
- from 11:00 to 13:00
- from 16:00 to 21:00.

You can either choose for the pump to operate according to the default schedule or customise it.

Setting the pump

Settings are done directly on the pump's operating panel. For instructions on how to set continuous 100 % mode and operating periods, scan the QR codes below to see the COMFORT quick guide and the COMFORT Digital Timer instruction video.



COMFORT quick guide

net.grundfos.com/qr/i/99245820



COMFORT Digital Timer instruction video

<http://v2.t2g.me/?q=fc0652a6>

Operating panel

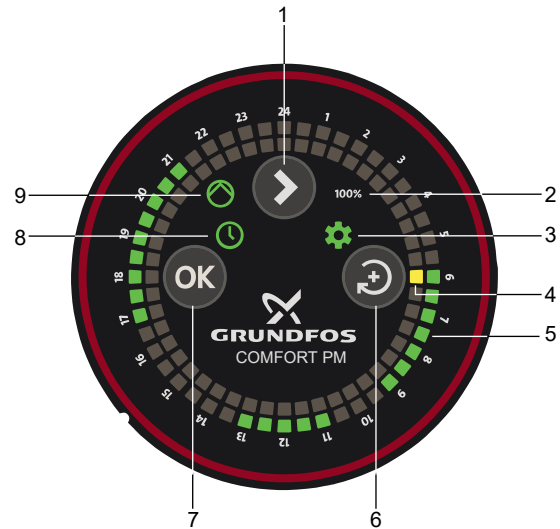

Operating panel of the COMFORT BDT and BXDT PM models in default timer mode

Pos.	Description
1	Arrow button for changing mode.
2	100 % LED. When lit, the pump runs according to continuous 100 % mode.
3	Gear wheel LED. It lights up when the actual time and operating time can be set.
4	Actual time. One LED equals a time interval of 30 minutes.
5	Timer LEDs showing the pump's operating periods. One LED equals a time interval of 30 minutes.
6	Change button for toggling the actual time and timer LEDs.
7	OK button for confirming, changing or deleting settings.
8	Activated timer function. When lit, the LED indicates that the timer function is activated and that operating periods have been set.
9	Pump LED. It indicates that the pump is operating.

In the event of a power cut the LED showing the actual time (4) blinks, indicating that the actual time setting may be incorrect.

QR99245820

QR_COMFORT-DT_INSTRUCTION/VIDEO

TM076110

4. Construction

Grundfos COMFORT PM circulator pumps are available in various pump housing versions and lengths incorporating isolating and non-return valves or prepared for subsequent fitting of such valves.

The motor can be separated from the pump housing, enabling easy maintenance and replacement.

The rotor bearing is self-adjusting and lubricated by the pumped liquid.

The pumps have the following characteristics:

- Parts in contact with the pumped liquid are hermetically separated from the stator by a stainless-steel spherical separator.
- The bearing has no play, and as it has only a single bearing point, it generates very low friction, resulting in reduced power input and noise.

Electrical insulation

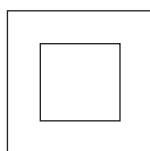

TM065197

Protection Class II symbol

All Grundfos COMFORT PM models are electrically double insulated (Protection Class II). This makes the protective earth connector obsolete.

Motor

The motor is a single-phase, 12-pole, permanent-magnet motor in conformity with the EMC directive.

The permanent-magnet motor has no rotating bearing shaft. A green indicator light on the motor is on when the motor is running.

The pump motor is impedance-protected and short-circuit-proof. No additional motor protection is required.

The terminal box is easily accessible and has functional cable connecting terminals. The cable entry is tight and incorporates cable relief.

Enclosure class: IP44

Insulation class: F.

Voltages

- Europe: 1 x 230 V, 50/60 Hz
- UK: 1 x 230 V, 50/60 Hz
- China: 1 x 230 V, 50/60 Hz
- USA: 1 x 115/230 V, 50/60 Hz.

Stator

The stator generates a magnetic field acting directly on the magnetic rotor. As a result, the rotor is caused to rotate. The axial components of the magnetic field act as an attractive force on the rotor, thus stabilising it in its longitudinal axis.

Spherical separator

The stainless-steel spherical separator hermetically seals the water-conducting part of the pump from the electrically active part of the motor without any additional seal.

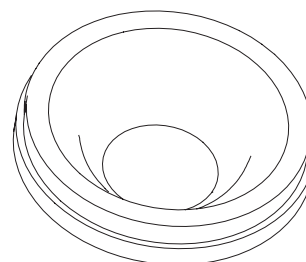

TM065201

Spherical separator

Bearing pin and bearing ball

The stainless-steel bearing pin is homogeneously welded by laser beam to the spherical separator and the bearing ball.

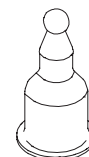

TM065202

Bearing pin

Rotor

The rotor is gimbal-mounted on the bearing ball with its own step bearing.

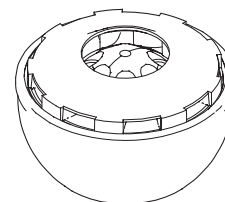

TM065203

Rotor

Pump housing

The pump housing is designed in such a way that a high hydraulic efficiency is achieved when the energy produced by the impeller is converted into pressure. The pump housing thread enables connection to standard pipe dimensions.

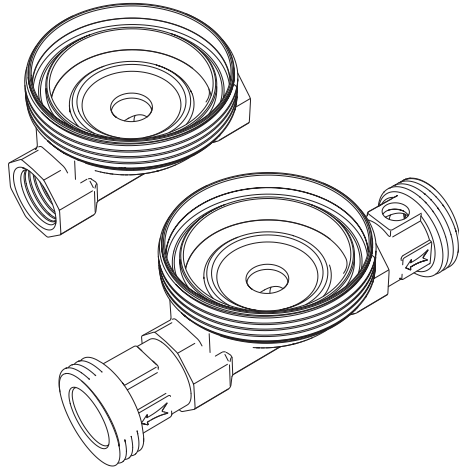

TM068283

Pump housing with and without valves

Isolating valve and non-return valve

The COMFORT pump types BX (Europe) and BU (USA) have a built-in isolating valve and a non-return valve.

The isolating valve ensures that maintenance can be carried out while the inlet side is isolated.

The non-return valve isolates the outlet side during maintenance.

Seal ring

The COMFORT pump has just one seal ring between the spherical motor and the pump housing. The seal ring material is resistant to hydrolysis and ageing, thus lasting the entire pump life.

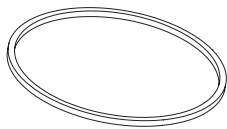

TM065206

Seal ring

Union nut

The union nut ensures that motor and pump housing are tightly connected. Thanks to the thread type, the seal ring is pressed evenly over the entire seal face.

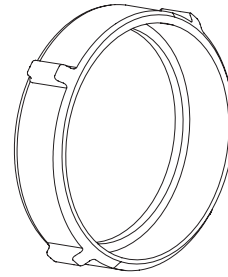

Union nut

TM065207

Sectional drawing

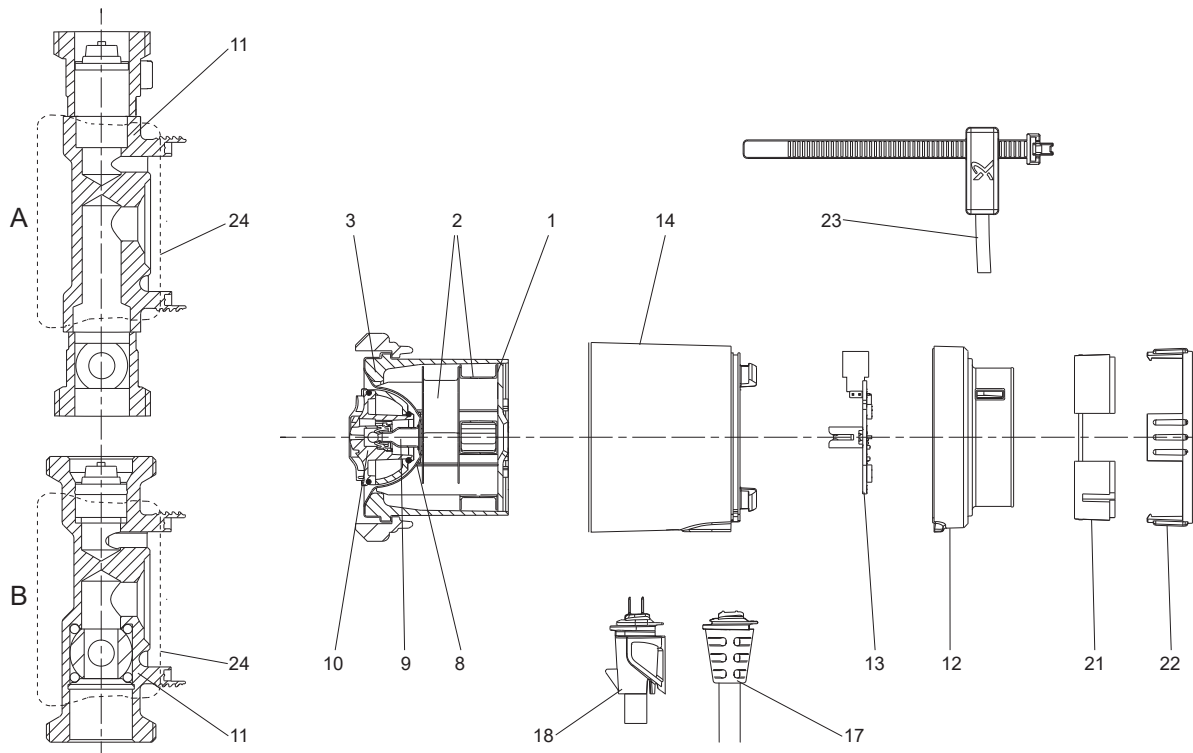

TM068303

Sectional drawing of COMFORT PM

Material specification

Pos.	Component	Material	EN	AISI
1	Stator lamination	Steel		
2	Stator windings	Copper wire and enamel		
3	Stator housing	Aluminium/P66		
8	Spherical separator	Stainless steel	1.4016	430
9	Rotor can, complete	Stainless steel/tungsten carbide	1.4571	316 Ti
10	Rotor, impeller	Stainless steel, EPDM, PPO, PFTE, graphite		
11	Pump housing A: Outside USA B: USA	Brass (CW617N) Brass (ECOBASS, CuZn ₂₁ Si ₃ P)	CW617N	
12	Terminal box cover	PC/ABS		
13	PC board with diode	FR 4		
14	Motor cover	PPO		
17	Cable with plug			
18	COMFORT plug (GB versions BA/BXA only)	PA66		
21	Cable ring 1 (AUTO _{ADAPT} variant only)	PC/ABS		
22	Cable ring 2 (AUTO _{ADAPT} variant only)	PC/ABS		
23	Temperature sensor (AUTO _{ADAPT} variant only)			
24	Insulation shells	EPP 55		

5. Performance curves

Curve conditions

The guidelines below apply to the performance curves on the following pages:

- Test liquid: airless water.
- The measurements for COMFORT PM have been made at a water temperature of 20 °C (68 °F).
- All curves show average values and must not be used as guarantee curves. If a specific minimum performance is required, individual measurements must be made.
- The COMFORT PM curves apply to a kinematic viscosity of $\nu = 1 \text{ mm}^2/\text{s}$ (1 cSt).

The conversion between head H [m] and pressure p [kPa] was made for water with a density of $\rho = 1000 \text{ kg/m}^3$. For liquids with other densities, for example hot water, the outlet pressure is proportional to the density.

6. Data sheets

COMFORT 15-14 B PM, 15-14 B PM DACH, 15-14 B PM CN

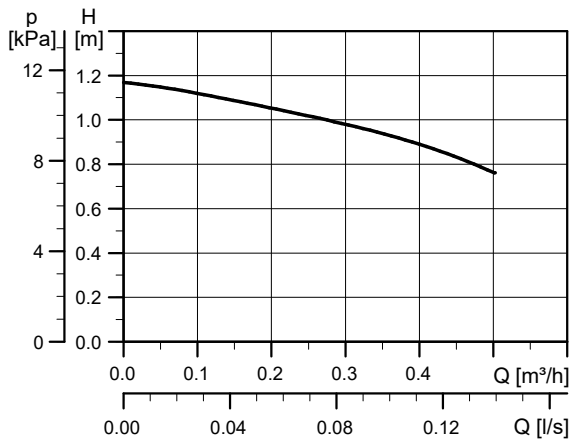

TM063622



TM062192

Connections:	Rp 1/2. Various fittings, see section 8.1 Fittings.
System pressure:	Max. 10 bar.
Liquid temperature:	2-95 °C (TF 95).
IP class:	IP44

Electrical data, 1 x 230 V, 50/60 Hz

P1 [W (Hp)]	I _{1/1} [A]
7	0.07

Dimensions

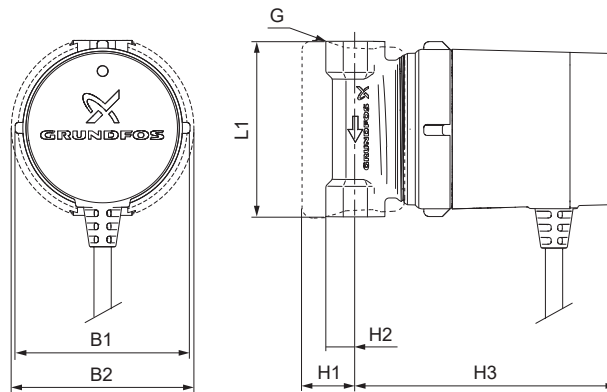

TM068292

Pump type	Dimensions [mm]							Weights [kg]		Shipping volume [m³]
	L1	H1	H2	H3	B1	B2	G	Net	Gross	
COMFORT 15-14 B PM										
COMFORT 15-14 B PM DACH	80	25	13.5	119	79.5	84	Rp 1/2	1.00	1.12	0.0026
COMFORT 15-14 B PM CN										

COMFORT 15-14 BA PM, 15-14 BA PM DACH, 15-14 BA PM CN

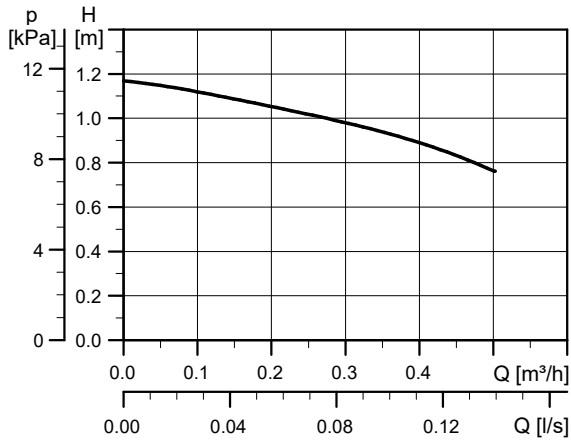

TM063622



TM1040640

Electrical data, 1 x 230 V, 50/60 Hz

P1 [W (Hp)]	I _{1/1} [A]
7	0.07

Connections: Rp 1/2. Various fittings, see section 8.1 Fittings.

System pressure: Max. 10 bar

Liquid temperature: 2-95 °C (TF 95).

IP class: IP44

Dimensions

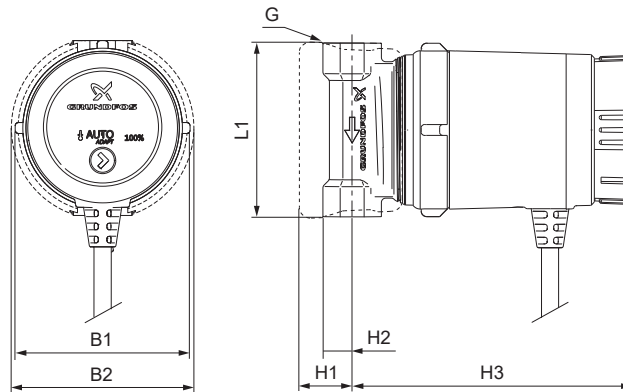

TM069258

Pump type	Dimensions [mm]							Weights [kg]		Shipping volume [m³]
	L1	H1	H2	H3	B1	B2	G	Net	Gross	
COMFORT 15-14 BA PM										
COMFORT 15-14 BA PM DACH	80	25	13.5	129	79.5	84	Rp 1/2	1.00	1.12	0.0026
COMFORT 15-14 BA PM CN										

COMFORT 15-14 BDT PM, 15-14 BU PM DACH, 15-14 BDT PM CN

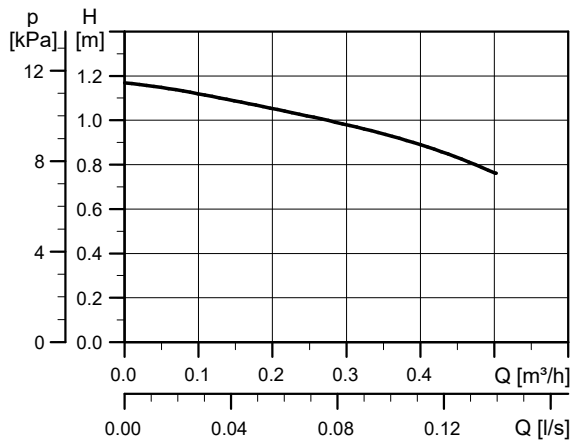

TM063622



TM082194

Connections:	Rp 1/2. Various fittings, see section 8.1 Fittings.
System pressure:	Max. 10 bar
Liquid temperature:	2-95 °C (TF 95).
IP class:	IP44

Electrical data, 1 x 230 V, 50/60 Hz

P1 [W]	I _{1/1} [A]
7	0.07

Dimensions

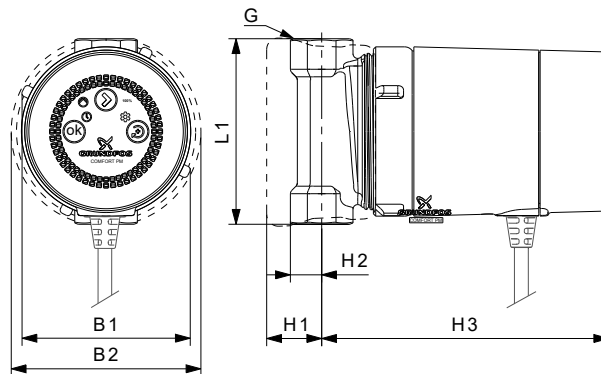

TM076114

Pump type	Dimensions [mm]							Weights [kg]		Shipping volume [m³]
	L1	H1	H2	H3	B1	B2	G	Net	Gross	
COMFORT 15-14 BDT PM										
COMFORT 15-14 BDT PM DACH	80	25	13.5	124	80	84	Rp 1/2	1.00	1.1	0.0026
COMFORT 15-14 BDT PM CN										

COMFORT 15-14 BX PM, COMFORT 15-14 BX PM DACH

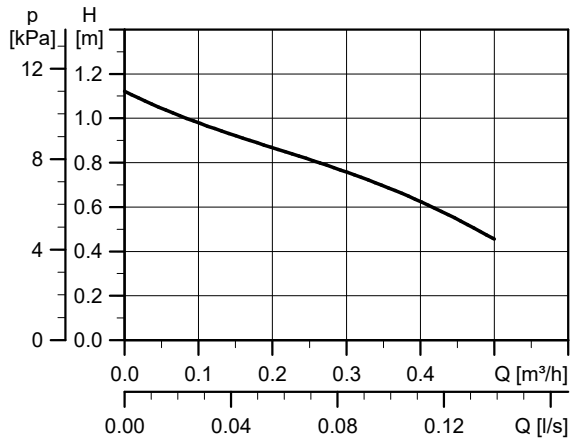

TM068415



TM082193

Connections:	G 1
System pressure:	Max. 10 bar
Liquid temperature:	2-95 °C (TF 95).
IP class:	IP44

Electrical data, 1 x 230 V, 50/60 Hz

P1 [W]	I _{1/1} [A]
7	0.07

Dimensions

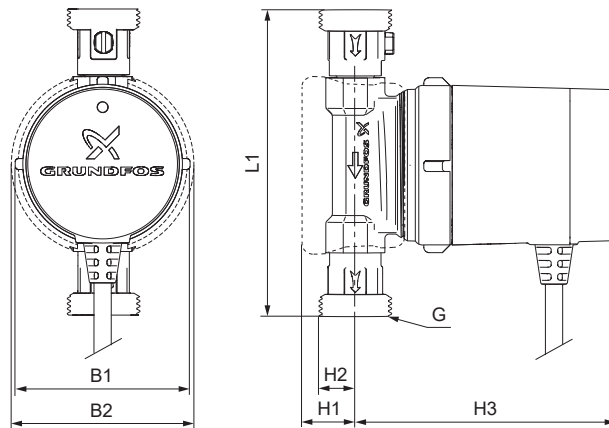

TM068285

Pump type	Dimensions [mm]						Weights [kg]		Shipping volume [m³]	
	L1	H1	H2	H3	B1	B2	G	Net		Gross
COMFORT 15-14 BX PM	140	25	21	119	79.5	84	G 1	1.35	1.51	0.0034
COMFORT 15-14 BX PM DACH										

COMFORT 15-14 BXA PM, 15-14 BXA PM DACH

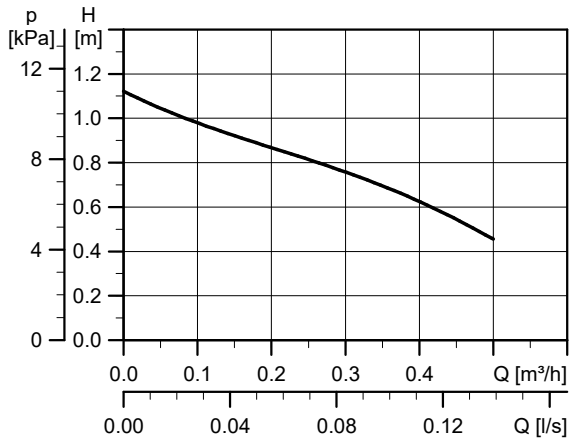

TM068415



TM082196

Electrical data, 1 x 230 V, 50/60 Hz

P1 [W]	I _{1/1} [A]
7	0.07

Connections:	G 1
System pressure:	Max. 10 bar
Liquid temperature:	2-95 °C (TF 95).
IP class:	IP44

Dimensions

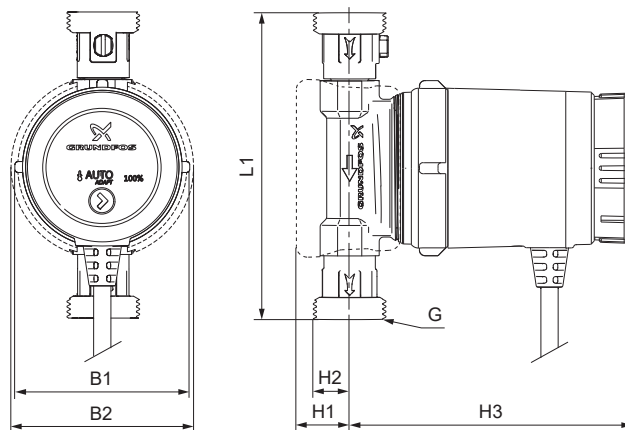

TM068290

Pump type	Dimensions [mm]							Weights [kg]		Shipping volume [m³]
	L1	H1	H2	H3	B1	B2	G	Net	Gross	
COMFORT 15-14 BXA PM	140	25	21	129	79.5	84	G 1	1.35	1.51	0.0034
COMFORT 15-14 BXA PM DACH										

COMFORT 15-14 BXDT PM, 15-14 BXU PM DACH

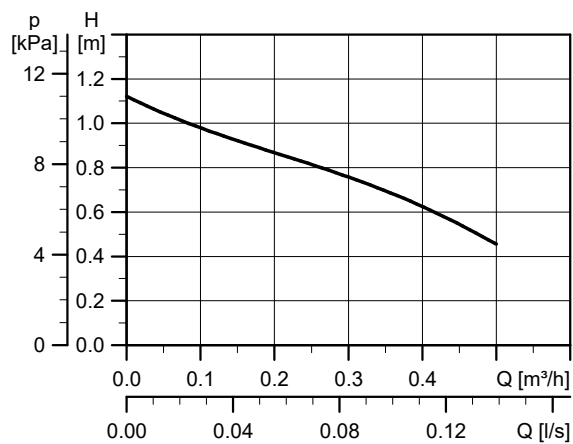

TM068415



TM082195

Connections:	G 1
System pressure:	Max. 10 bar
Liquid temperature:	2-95 °C (TF 95).
IP class:	IP44

Electrical data, 1 x 230 V, 50/60 Hz

P1 [W]	I _{1/1} [A]
7	0.07

Dimensions

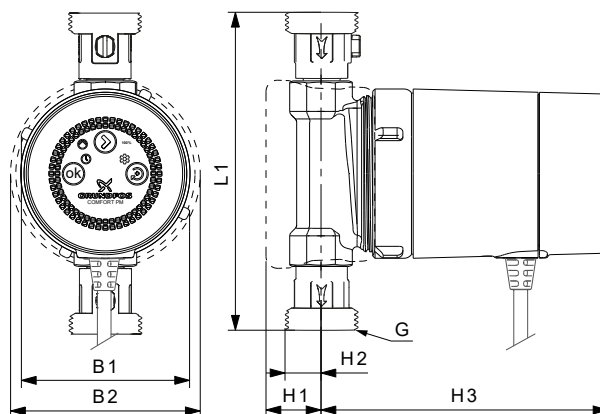

TM076191

Pump type	Dimensions [mm]							Weights [kg]		Shipping volume [m³]
	L1	H1	H2	H3	B1	B2	G	Net	Gross	
COMFORT 15-14 BXDT PM	140	25	21	124	79.5	84	G 1	1.2	1.3	0.0026
COMFORT 15-14 BXDT PM DACH										

COMFORT 15-14 B PM GB

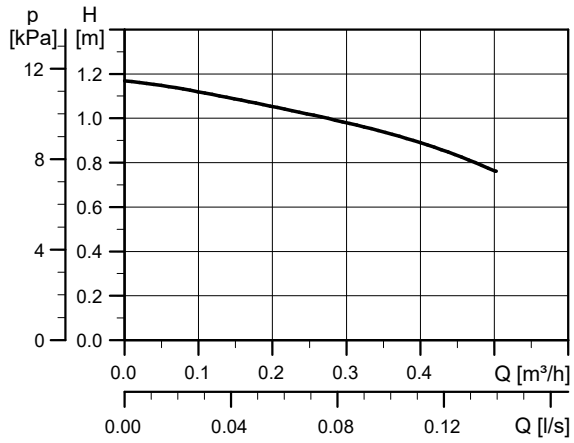

TM063622



TM082197

Connections: Rp 1/2. Various fittings, see section 8.1 Fittings.

System pressure: Max. 10 bar

Liquid temperature: 2-95 °C (TF 95).

IP class: IP44

Electrical data, 1 x 230 V, 50/60 Hz

P1 [W]	I _{1/1} [A]
7	0.07

Dimensions

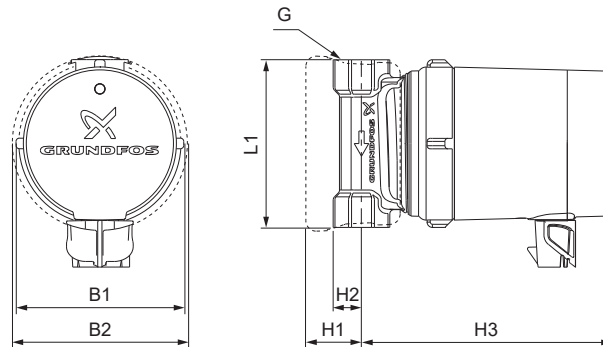

TM068280

Pump type	Dimensions [mm]							Weights [kg]		Shipping volume [m³]
	L1	H1	H2	H3	B1	B2	G	Net	Gross	
COMFORT 15-14 B PM GB	80	25	13.5	119	79.5	84	Rp 1/2	1.00	1.12	0.0026

COMFORT 15-14 BA PM GB

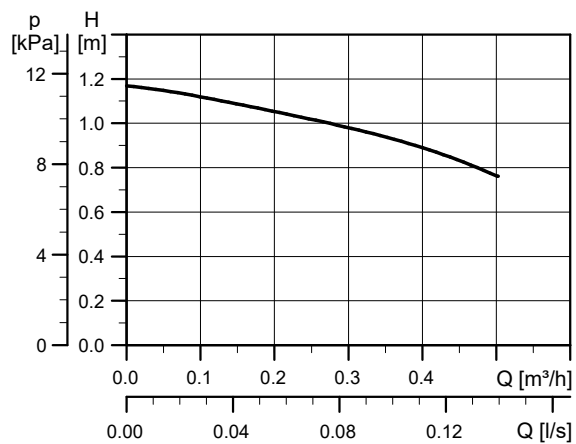

TM063622



TM082198

Electrical data, 1 x 230 V, 50/60 Hz

P1 [W]	I _{1/1} [A]
7	0.07

Connections: Rp 1/2. Various fittings, see section 8.1 Fittings.

System pressure: Max. 10 bar (145 psi).

Liquid temperature: 2-95 °C (TF 95).

IP class: IP44

Dimensions

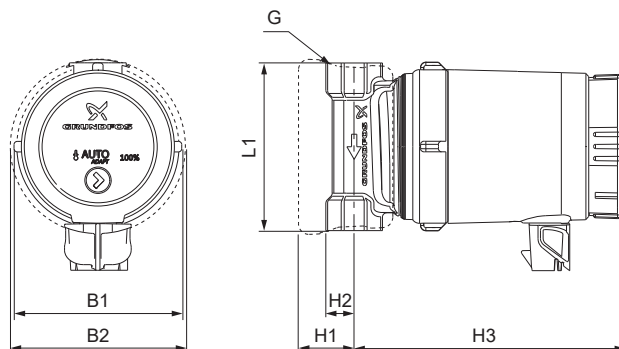

TM068281

Pump type	Dimensions [mm]							Weights [kg]		Shipping volume [m³]
	L1	H1	H2	H3	B1	B2	G	Net	Gross	
COMFORT 15-14 BA PM GB	80	25	13.5	129	79.5	84	Rp 1/2	1.00	1.12	0.0026

COMFORT 15-14 MB PM DACH

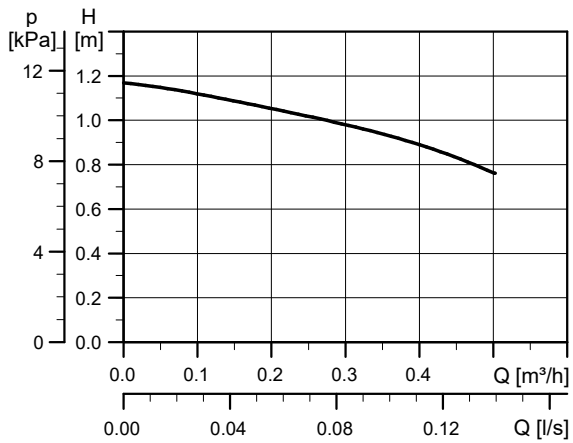

TM063622



TM1040639

Connections:	Rp 1/2. Various fittings, see section 8.1 Fittings.
System pressure:	Max. 10 bar
Liquid temperature:	2-95 °C (TF 95).
IP class:	IP44

Electrical data, 1 x 230 V, 50/60 Hz

P1 [W]	I _{1/1} [A]
7	0.07

Dimensions

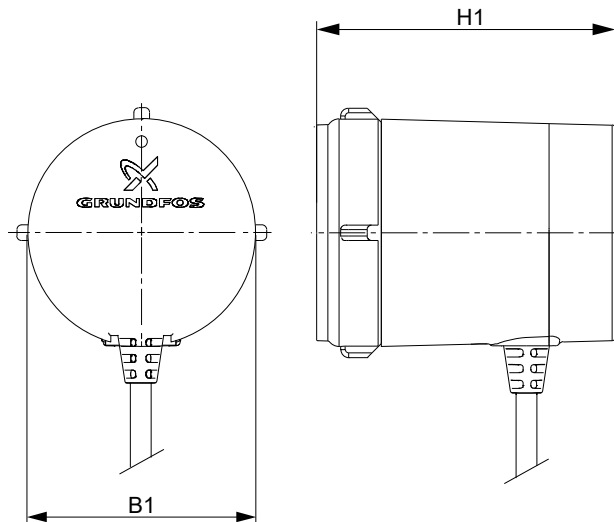

TM1040354

Pump type	Dimensions [mm]		Weights [kg]		Shipping volume [m³]
	H1	B1	Net	Gross	
COMFORT 15-14 MB PM DACH	25	79.5	1.00	1.12	0.0026

COMFORT 10-16 T PM BU/LC

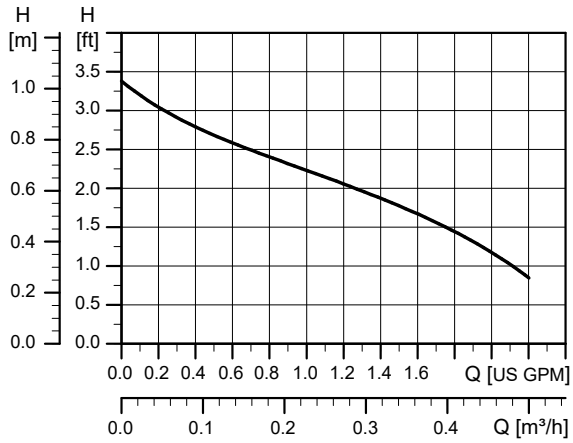

TM063625



TM082199

Connections:	1/2" NPT
System pressure:	Max. 145 psi
Liquid temperature:	2-80 °C / 35-176 °F
IP class:	IP44

Electrical data, 1 x 115/230 V, 50/60 Hz

P1 [W (Hp)]	I _{1/1} [A]
6 (0.008)	0.07

Dimensions

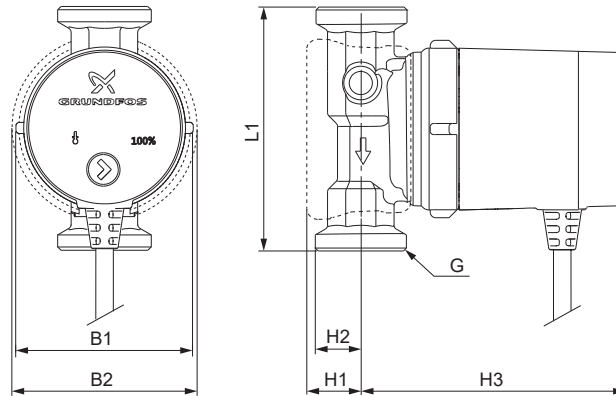

TM077152

Pump type	Dimensions [inches]							Weights [lb]		Shipping volume [ft³]
	L1	H1	H2	H3	B1	B2	G	Net	Gross	
COMFORT 10-16 T PM BU/LC	4 1/3	1	7/8	5	3	3 1/3	1 1/4" NPSM	3.4	3.8	0.152

COMFORT 10-16 DT PM BU/LC

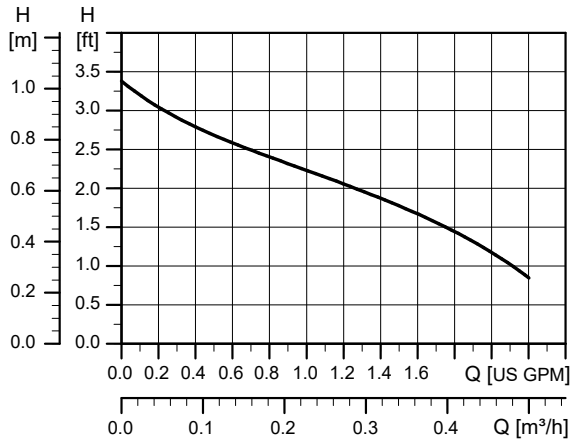

TM063625



TM082200

Connections:	1 1/4" NPSM
System pressure:	Max. 145 psi
Liquid temperature:	2-80 °C / 35-176 °F
IP class:	IP44

Electrical data, 1 x 115/230 V, 50/60 Hz

P1 [W (Hp)]	I _{1/1} [A]
6 (0.008)	0.07

Dimensions

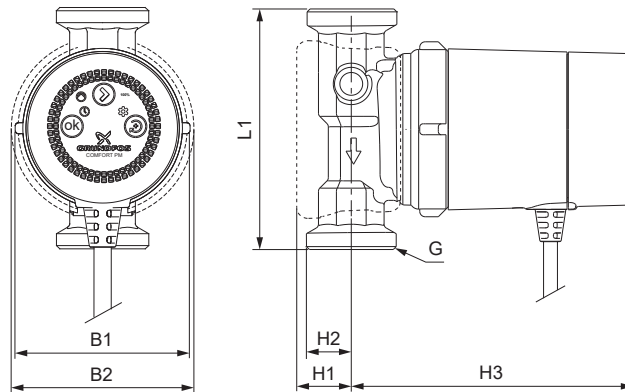

TM076192

Pump type	Dimensions [inches]							Weights [lb]		Shipping volume [ft³]
	L1	H1	H2	H3	B1	B2	G	Net	Gross	
COMFORT 10-16 DT PM BU/LC	4 1/3	1	7/8	4 7/8	3	3 1/3	1 1/4" NPSM	3.4	3.8	0.152

COMFORT 10-16 A PM B5/LC

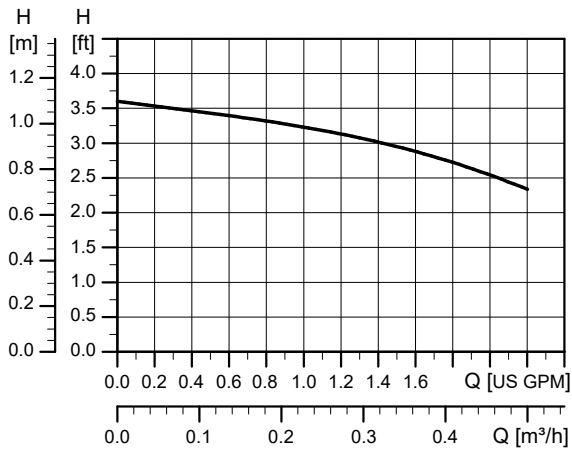

TM063624

Electrical data, 1 x 115/230 V, 50/60 Hz

P1 [W (Hp)]	I _{1/1} [A]
6 (0.008)	0.07



TM1040640

Connections:	1/2" sweat
System pressure:	Max. 145 psi
Liquid temperature:	2-80 °C / 35-176 °F
IP class:	IP44

Dimensions

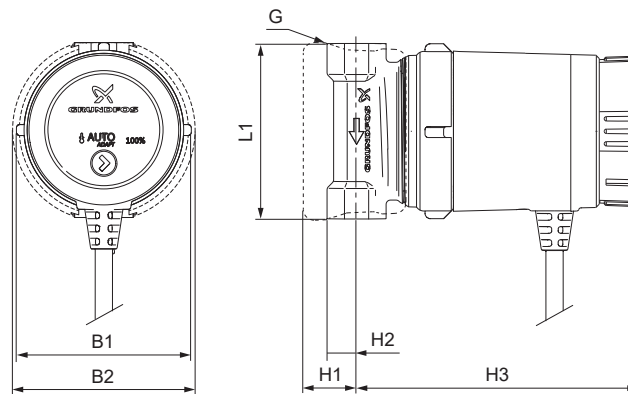

TM069448

Pump type	Dimensions [inches]							Weights [lb]		Shipping volume [ft ³]
	L1	H1	H2	H3	B1	B2	G	Net	Gross	
COMFORT 10-16 A PM B5/LC	3 1/8	1	1/2	5 1/4	3	3 1/3	1/2" sweat	2.6	2.9	0.116

COMFORT 10-16 A PM BN5/LC

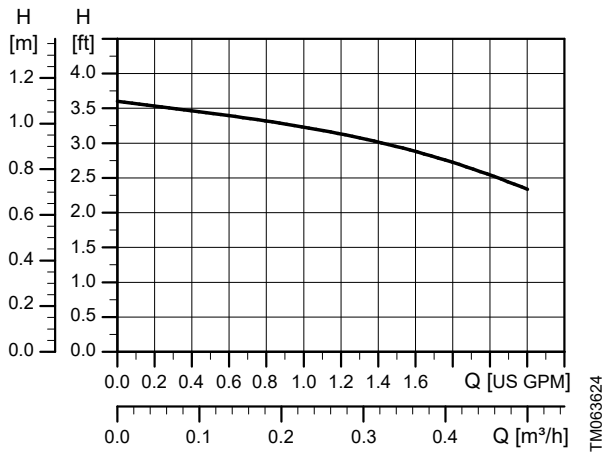

TM1040640

Electrical data, 1 x 115/230 V, 50/60 Hz

P1 [W (Hp)]	I _{1/1} [A]
6 (0.008)	0.07

Connections:	1/2" NPT
System pressure:	Max. 145 psi
Liquid temperature:	2-80 °C / 35-176 °F
IP class:	IP44

Dimensions

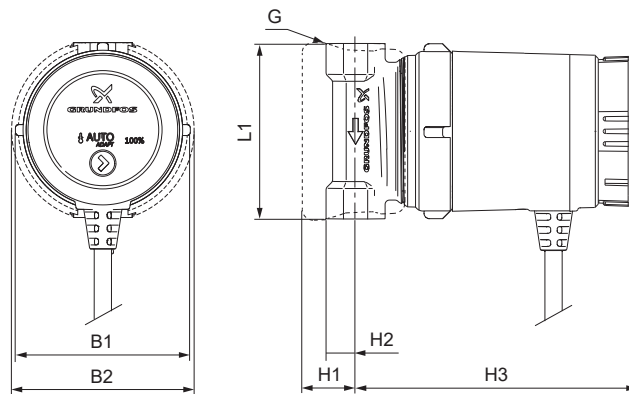

TM069448

Pump type	Dimensions [inches]							Weights [lb]		Shipping volume [ft³]
	L1	H1	H2	H3	B1	B2	G	Net	Gross	
COMFORT 10-16 A PM BN5/LC	3 1/8	1	1/2	5 1/4	3	3 1/3	1/2" NPT	2.6	2.9	0.116

COMFORT 10-16 A PM BU/LC

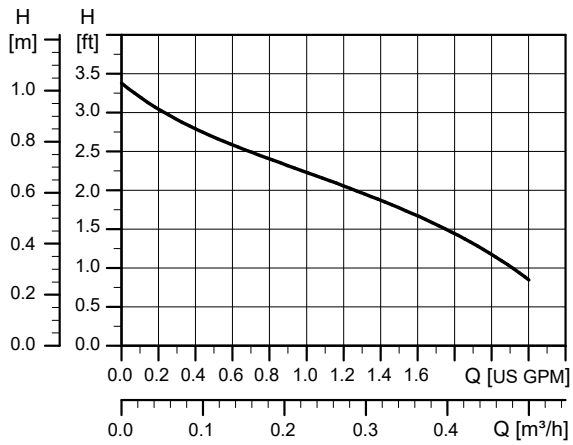

TM063625



TM082203

Electrical data, 1 x 115/230 V, 50/60 Hz

P1 [W (Hp)]	I _{1/1} [A]
6 (0.008)	0.07

Connections: 1 1/4" NPSM

System pressure: Max. 145 psi

Liquid temperature: 2-80 °C / 35-176 °F

IP class: IP44

Dimensions

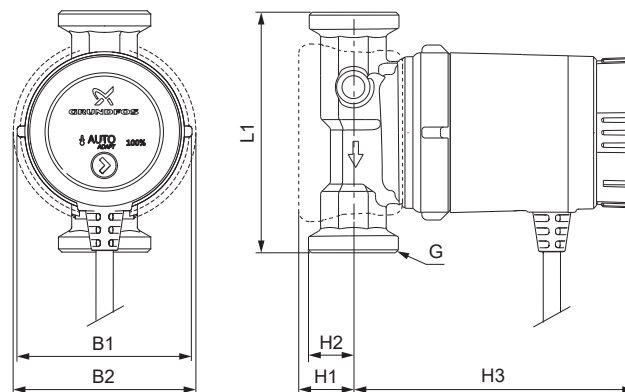

TM068300

Pump type	Dimensions [inches]							Weights [lb]		Shipping volume [ft³]
	L1	H1	H2	H3	B1	B2	G	Net	Gross	
COMFORT 10-16 A PM BU/LC	4 1/3	1	7/8	5 1/4	3	3 1/3	1 1/4" NPSM	3.4	3.8	0.152

7. Product numbers

COMFORT, International, DACH, GB, CN, RU, 50/60 Hz

Market region	Pump type	Product number	Port-to-port length [mm]	Connection	Supplied with		Data sheet
					Plug	Isolating valve Non-return valve	
International	COMFORT 15-14 B PM	97916771	80 mm	Rp 1/2			page 6.1 COMFORT 15-14 B PM, 15-14 B PM DACH, 15-14 B PM CN
	COMFORT 15-14 BA PM	97916757					page 6.2 COMFORT 15-14 BA PM, 15-14 BA PM DACH, 15-14 BA PM CN
	COMFORT 15-14 BDT PM	99812350					page 6.3 COMFORT 15-14 BDT PM, 15-14 BU PM DACH, 15-14 BDT PM CN
	COMFORT 15-14 BX PM	97916772	140 mm	G 1		●	page 6.4 COMFORT 15-14 BX PM, COMFORT 15-14 BX PM DACH
	COMFORT 15-14 BXA PM	97916749					page 6.5 COMFORT 15-14 BXA PM, 15-14 BXA PM DACH
	COMFORT 15-14 BXDT PM	99831281					page 6.6 COMFORT 15-14 BXDT PM, 15-14 BXU PM DACH
Germany Austria Switzerland (D-A-CH)	COMFORT 15-14 B PM DACH	97989265	80 mm	Rp 1/2			page 6.1 COMFORT 15-14 B PM, 15-14 B PM DACH, 15-14 B PM CN
	COMFORT 15-14 BA PM DACH	99302331					page 6.2 COMFORT 15-14 BA PM, 15-14 BA PM DACH, 15-14 BA PM CN
	COMFORT 15-14 BU PM DACH	99831284					page 6.3 COMFORT 15-14 BDT PM, 15-14 BU PM DACH, 15-14 BDT PM CN
	COMFORT 15-14 MB PM DACH	99327264	140 mm	G 1		●	page 6.9 COMFORT 15-14 MB PM DACH
	COMFORT 15-14 BX PM DACH	97989266					page 6.4 COMFORT 15-14 BX PM, COMFORT 15-14 BX PM DACH
	COMFORT 15-14 BXA PM DACH	99302332					page 6.5 COMFORT 15-14 BXA PM, 15-14 BXA PM DACH
COMFORT 15-14 BXU PM DACH	99831285	page 6.6 COMFORT 15-14 BXDT PM, 15-14 BXU PM DACH					
Great Britain (GB)	COMFORT 15-14 B PM GB	99164484	80 mm	Rp 1/2		●	page 6.7 COMFORT 15-14 B PM GB
	COMFORT 15-14 BA PM GB	99164487					page 6.8 COMFORT 15-14 BA PM GB
China (CN)	COMFORT 15-14 B PM CN	98485504	80 mm	Rp 1/2			page 6.1 COMFORT 15-14 B PM, 15-14 B PM DACH, 15-14 B PM CN
	COMFORT 15-14 BA PM CN	98485557					page 6.2 COMFORT 15-14 BA PM, 15-14 BA PM DACH, 15-14 BA PM CN
	COMFORT 15-14 BDT PM CN	99831292					page 6.3 COMFORT 15-14 BDT PM, 15-14 BU PM DACH, 15-14 BDT PM CN



COMFORT, USA, 50/60 Hz

Market region	Pump type	Product number	Port-to-port length [inches]	Connection	Supplied with		Data sheet
					Line cord	Isolating valve Non-return valve	
USA ★	COMFORT 10-16 T PM BU/LC	99412493	4 1/3"	1 1/4" NPSM	•	•	page 6.10 COMFORT 10-16 T PM BU/LC
	COMFORT 10-16 DT PM BU/LC	99812354			•	•	page 6.11 COMFORT 10-16 DT PM BU/LC
	COMFORT 10-16 A PM B5/LC	98420222	3 1/8"	1/2" NPT	•		page 6.12 COMFORT 10-16 A PM B5/LC
	COMFORT 10-16 A PM BN5/LC	98420223			•		page 6.13 COMFORT 10-16 A PM BN5/LC
	COMFORT 10-16 A PM BU/LC	98420224	4 1/3"	1 1/4" NPSM	•	•	page 6.14 COMFORT 10-16 A PM BU/LC

★ Lead-free pump housing

8. Accessories

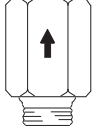
Fittings

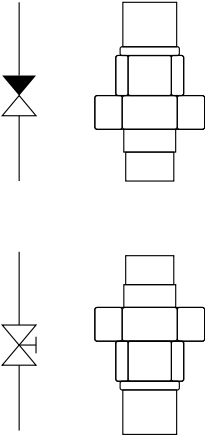
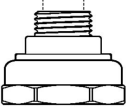
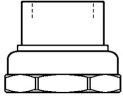
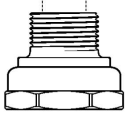
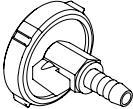
Fitting	Description	Connection	Material	Product number
	TM018647 Non-return valve	1/2	Brass	96433904
	TM018648 Isolating valve	1/2	Brass	96433905
	TM1040355 Fittings with integrated non-return valve and isolating valve 15mm soldering/R $\frac{1}{2}$ " connection incl.	G 1 x Rp 1/2 int.	Brass	00ID8748
	TM018643 Union set	G 1 1/4 x 15 mm int. R 1/2 ext.	Brass	96433907
	TM018644 Union set	G 1 1/4 x Rp 3/4 int.	Brass	96433908
	TM018645 Union set	G 1 1/4 x Rp 1/2 int. R 3/4 ext.	Brass	96433909
	TM018560 Venting flange	Flange Union nut Hose	PP Brass PE	96433906
	Bulk COMFORT PM plug (80 pcs.)			98890117

Spare parts

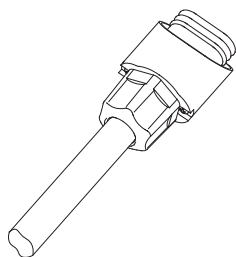

TM019911

Description	Product number
Spare plug for COMFORT PM	98685259

9. Grundfos Product Center

Online search and sizing tool to help you make the right choice.

From the international view, you can select your specific country to view the product range available to you.

International view: <https://product-selection.grundfos.com>

All the information you need in one place

Performance curves, technical specifications, pictures, dimensional drawings, motor curves, wiring diagrams, spare parts, service kits, 3D drawings, documents, system parts. The Product Center displays any recent and saved items - including complete projects - right on the main page.

Downloads

On the product pages, you can download installation and operating instructions, data booklets, service instructions, etc., in PDF format.



When you select your country, you will see the menus below. Note that some menus may not be available depending on the country.

Example: <https://product-selection.grundfos.com/uk>

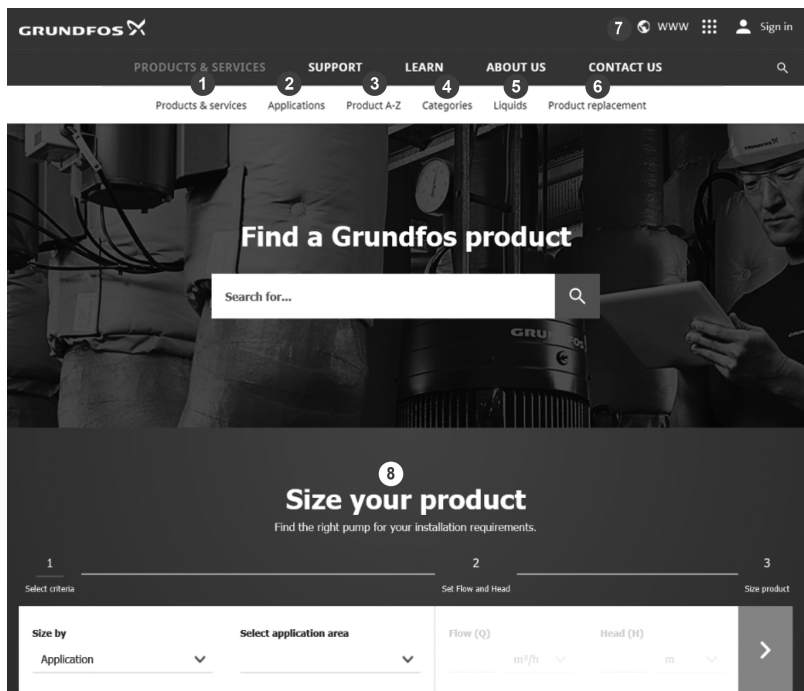

Pos. Description

- | Pos. | Description |
|------|---|
| 1 | Products & services enables you to find products and documents by typing a product number or name into the search field. |
| 2 | Applications enables you to choose an application to see how Grundfos can help you design and optimise your system. |
| 3 | Products A-Z enables you to look through a list of all the Grundfos products. |
| 4 | Categories enables you to look for a product category. |
| 5 | Liquids enables you to find pumps designed for aggressive, flammable or other special liquids. |
| 6 | Product replacement enables you to find a suitable replacement. |
| 7 | WWW enables you to select the country, which changes the language, the available product range and the structure of the website. |
| 8 | Sizing enables you to size a product based on your application and operating conditions. |

98553150 04.22

ECM: 1340027

GRUNDFOS Holding A/S
Poul Due Jensens Vej 7
DK-8850 Bjerringbro
Tel: +45 87 50 14 00
www.grundfos.com

GRUNDFOS 