



HYDRONIC HEATING SYSTEMS



GRUNDFOS 

Possibility in every drop

Your personal guide for hydronic heating systems

Disclaimer

This hydronic heating systems manual is intended to provide an overview of various systems and processes that incorporate Grundfos products. The information presented here is only for illustration and discussion purposes. The manual is not a substitute for the documentation that accompanies Grundfos products or other products discussed in this publication.

When undertaking any of the projects described here or using any Grundfos product, you should always determine and comply with applicable building codes, permit requests, and other laws. There may be national, state, or local codes that govern the installation of equipment set forth herein.

Boilers, furnaces, pumps, and other similar equipment are sophisticated products that require caution. Working with water, glycol and other materials, alone or in conjunction with electricity, gas or other energy sources, presents certain dangers both to persons and property. It is critical technicians, installers, system designers, and owners be aware of all dangers inherent in the products and systems. You should consult, understand, and heed all cautions, warnings, and danger designations listed in the product or process documentation.

Nothing herein shall be construed as a warranty, expressed or implied. All Grundfos products carry warranties. Consult the specific product information to determine the terms of such warranties.



1. HEAT SOURCES

1

2. PIPING STRATEGIES

2

3. RADIANT HEATING

3

4. PUMP SELECTION

4

5. INSTALLATION TIPS

5

6. TROUBLE SHOOTING

6

7. REFERENCES

7

1. HEAT SOURCES

Boiler types8 - 9
 Solid fuel10
 Condensing - oil and gas11
 Converting steam to hot water12
 Integrating condensing/modulation13
 Annual maintenance14
 Direct hot water - Boiler generated15
 Indirect and direct water heaters16
 Tankless water heaters17
 Solar hot water18 - 19

2. PIPING STRATEGIES

Basic piping strategies20
 Pumping away21
 Primary, secondary, and tertiary22
 Series23
 One-pipe distribution24
 Parallel25
 Two-pipe direct return26
 Two-pipe reverse return27
 Zoning28
 Zoning with circulators29
 Zoning with valves30
 Injection31
 ALPHA Range32 - 33

3. RADIANT HEATING

Introduction34
 Concrete slab35
 Under-floor35
 Above-floor36
 Walls and ceiling36
 Snow melting37 - 38

4. PUMP SELECTION

Determining metallurgy40
 Static, dynamic, and total dynamic head41
 Selecting the right circulator42 - 43
 Energy rating label44
 UPSe, ALPHA45 - 47
 ALPHA1 26-99, ALPHA2 26-9948 - 49
 UPS 15-58, 26-99, 43-4450
 UPS 26-150, 43-100, 50-6051
 MAGNA range52
 MAGNA353 - 60
 TPE361 - 62
 Large UP63
 Large UPS64
 Dielectric isolation valves65
 Zone valves66
 Zone controls67
 Grundfos GO app68 - 69

5. INSTALLATION TIPS

Eliminating air70 - 71
 Pump installation72
 Thermal expansion tank sizing73 - 74
 Sizing water heater - tank and tankless75
 Calculating heat losses76 - 77
 Outdoor reset78
 Pipe sizing79

6. TROUBLE SHOOTING

Water hammer/ pipe noise transmission80 - 81
 Corrosion of pipes/ scale buildup82 - 85
 Circulators86 - 87
 Baseboard heating87 - 88
 Valves89
 Water heaters, radiators90 - 91
 Noises92
 Piping93
 Air, outdoor reset control, ALPHA trend data94

7. REFERENCES



Possibility in every drop is our statement of relentless ambition, optimism, and belief – that wherever some see problems, we see opportunities to make a difference.

It is our commitment to meet the world's water, energy, and climate challenges with the utmost care, respect, and responsibility.

It promises solutions through innovation that pushes the boundaries of what's possible, setting new standards in water utility, commercial, domestic, industrial, or an area of business we're yet to discover.

It proves our determination to stay curious, continually asking questions and pursuing new answers. To tell the world what we believe.

And we believe there is – possibility in every drop.

Our purpose

To pioneer solutions to the world's water and climate challenges and improve quality of life for people

Guide to this Technician's Handbook

Your time is valuable and we recognize that you are under more pressure than ever before to do more in less time.

We developed this booklet for you – our technicians, installers, system designers, and business owners. You'll find useful information about hydronic piping strategies and circulation, charts, graphs, and technician tips, to assist you while on the job.

We designed this resource for tough service, just like our products.

Boilers are typically the heart of a contemporary hydronic system.

Boiler types

- Atmospheric vented with draft diverter (chimney) – older style, low efficiency non-condensing boiler, on/off operation
- Atmospheric vented with draft diverter (chimney) – newer style, medium efficiency non-condensing boiler, on/off operation
- Indirect, sidewall vented to exterior with fan assisted exhaust – older style, low efficiency non-condensing boiler, on/off operation
- Indirect, sidewall vented to exterior, fan assisted (stainless steel exhaust) – newer style, higher efficiency non-condensing boiler, on/off operation
- Direct vent, sealed combustion vented to the exterior, fan assisted (stainless steel or plastic exhaust) – high efficiency condensing, on/off or modulating operation; condensate drained by gravity or pump
- Solid fuel boilers, wood/coal, indoor atmospheric chimney vented, outdoor with exhaust stack and open relief or relief valved on water side, normally isolated through a heat exchanger from the home's hydronic heating system

Boilers – atmospheric vented (old style)

Built long before fuel efficiency was a concern, their internal passageways were designed to handle raw gases, soot, and smoke from solid fuels. Heating of domestic water was typically accomplished by gravity flow to a storage tank.

Old chimneys are often unlined; it's vitally important to check the base each year to remove debris. This protects against infiltration of CO₂ and other by-products of combustion.

Boilers– atmospheric vented (newer style)

Later generations of boilers became smaller while offering much greater energy efficiency. Internal flue passageways grew closer together and design improvements further increased operational efficiency. At the time of their development, these types of boilers delivered 80% to 83% efficiency, considered then to be 'high efficiency.' Most were vented directly into chimneys.

As developments continued, new boilers soon exceeded to 85% efficiency range. But with system advancements, a key change involved the lowering of boiler flue gas temperatures. As these cooler exhaust gasses enter old chimneys, condensation can form easily (when flue temps fall below 350°F, the formation of acidic condensate becomes a constant challenge and can ruin masonry chimneys, especially those that are older and unlined). A flue liner must be installed to protect the occupants. Aluminum may be used for gas-fired systems and stainless steel must be used for oil.

Boilers – indirect, sidewall vented (low efficiency)

These systems offer no improvement in efficiency, but give greater flexibility when placing a boiler where a conventional chimney is not available.

Boilers – indirect, sidewall vented (high efficiency)

These boilers provide higher efficiency operation. Venting material changes to high-temp plastic or stainless steel. Boilers, for the first time, now include a secondary heat exchanger within the exhaust stream to harvest waste energy, greatly improving efficiency.

Boilers – direct vent, sealed combustion (higher efficiency)

These systems – designed to achieve mid-90% efficiency – extract a significant amount of waste energy from the waste stream. These boilers are ideal for low-temp hydronic systems, such as radiant heat and snow melt. One of the latest advancements is modulation of the burner. No longer an on/off appliance, these boilers dramatically reduce fuel use and can actually match heat output to the building's heat loss. Flue gas temps are often well below 350°F. Stainless steel or aluminum is the required venting material. Condensate is acidic and must be neutralized before drain discharge.

Solid fuel

Wood- and coal-fired boilers can be open or closed systems. Open systems tend to be large in water volume and located outdoors. Wood varies in BTU content, depending on the species and moisture content. Coal also varies in BTU content due to impurities.

Open systems use a heat exchanger loop when connected to a building's hydronic system. If subjected to freezing temperatures, the loop must be filled with a glycol solution.

Closed systems can be made to work in conjunction with an existing hydronic heating system and must be provided with an uninterrupted means for moving energy from the solid fuel boiler.

A relief valve with a BTU rating that equals or exceeds the maximum BTU capacity of the vessel and its fuel must be installed to direct any discharge away from people.

BTU (British thermal unit) is a measure of the heat content of fuels or energy sources.

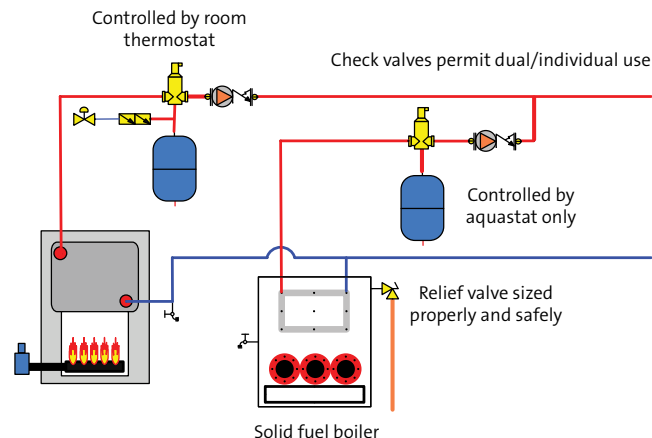

Condensing – oil / gas

The emergence of early condensing boilers began in this country about one decade ago. A few cast iron models were available with efficiencies approaching 90% and required stainless steel indirect venting. Draft inducer fans drew combustion gases through the boiler and rejected the gases to a sidewall vent termination.

More recently, these systems have advanced technologically and are plentiful. Stainless steel is used for many of the heat exchangers to extract sufficient heat from the combustion process to maintain exhaust temperatures below 350° F.

Condensate is mildly acidic and must be neutralized before discharging into metal drain line piping. This new generation of condensing boilers can achieve mid-90% efficiencies. They're ideally suited for low temperature radiant heat and snow melt systems.

One of the latest advancements to these systems is modulation of the burner. No longer an on/off appliance, these boilers are adept at dramatically reducing fuel use. Venting requirements vary widely between manufacturers, as do piping and pumping needs. To ensure proper boiler function, it's essential to use a calibrated combustion analyzer.

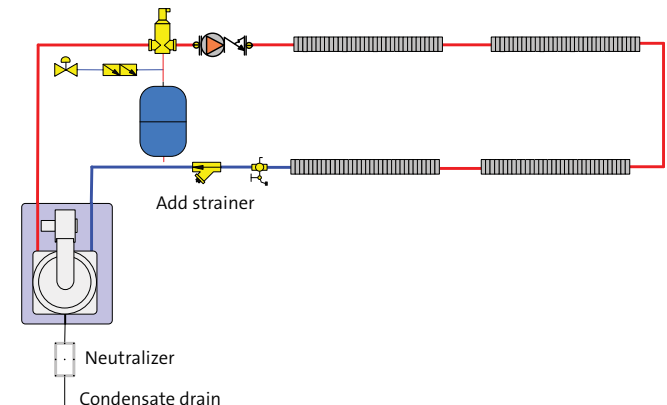

1 Converting steam to hot water

Many two-pipe steam systems can be converted to hot water. Energy savings can be dramatic if a modulating condensing boiler is used.

If the radiators are connected across both the top and bottom, you can begin to determine if hot water heating is an option. The first step requires a complete room-by-room heat loss and survey of the heat emitters to ensure they'll meet design-load conditions.

It's imperative that each radiator has the older-style steam valve replaced and has the bellows removed from the trap or has the bellows replaced with a return union/elbow. Many cast iron radiators were designed to be used for steam or hot water and will have a threaded plug near the top of one end section. This can be removed by center-drilling the plug and gently extracting it. A loose-key air vent can then be installed and the radiator made ready for service by tightening both supply/return unions.

We recommend installing a strainer as rust and debris frequently find their way to the boiler. Replace the strainer's plug with a boiler drain to quickly blow-down the unit's screened compartment.

Once filled with water, any leaks can be found. It's a good idea to tell the owner that this is a possibility that would require repair. A homeowner may also enjoy knowing that a hot water system – especially if you've used outdoor reset – will be safer, more comfortable, and more energy efficient.

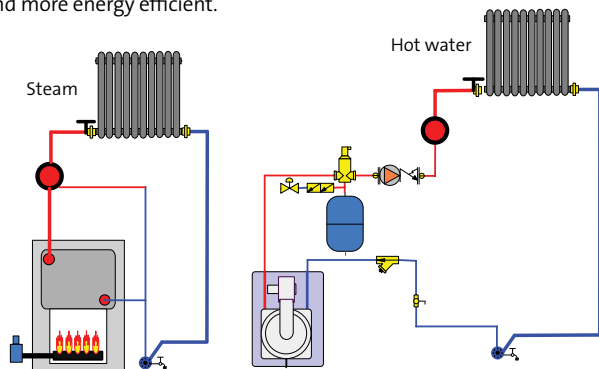

1 Integrating condensing/modulation with older systems

Existing high-temp hydronic systems with baseboards, convectors, or cast iron radiators can be switched over to condensing, modulating operation.

The first step requires a room-by-room heat loss survey. Be sure to include each room's existing heat emitter. Each type of heat emitter has a limited amount of BTU output, which is based on its size and heating curve. The charts included in this booklet will help you determine the output of each room's heat source at varying water temperatures. Once you've completed the heat loss survey and know the room's BTU load, the heat emitter's capacity will determine how low you can go with water temperature delivery.

The ΔT across each heat emitter can be quickly determined by subtracting the BTU output from the GPM flow rate. The purpose behind the math? If you can keep the return water's temperature below 140° F (what is needed to achieve condensate heat recovery within the boiler), you'll maximize the "mod-con's" energy efficiency.

As mentioned above, the addition of a Y-strainer to capture water-borne debris is recommended. Primary/secondary piping is an excellent method to ensure the boiler has the required GPM flow rate at all times.

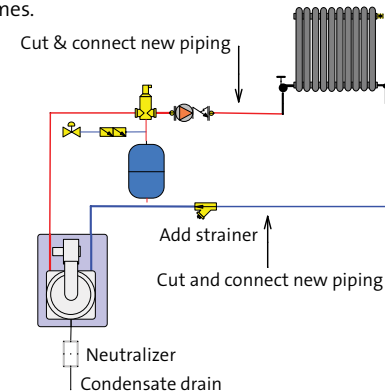

Annual maintenance

Most heating systems suffer from neglect. As you well know, homeowners often forget about mechanical systems – until there's a crisis. Lucky you! Here are some tips that may help you on the job.

Older style boilers often vent into chimneys:

- Clean and inspect flue passageways and exhaust piping
- Inspect piping, circulators, and controls
- Inspect and clean chimney
- Perform combustion analysis

Indirect-vent boilers (non-condensing):

In addition to the above...

- Exhaust vent piping must be adequately supported (no sags)
- Exhaust termination points - inspect for blockages: bee's nests, rodents, perimeter clearance from landscaping, and potential for snow drifting/accumulation

Direct-vent condensing boilers:

In addition to the above...

- Open combustion chamber to chemically clean all internal passageways
- Inspect and clean condensate trap/drain line
- Inspect and verify condensate pump operation (if present)
- Clean or replace flame sensors and/or probes
- Recharge condensate neutralizer
- An electronic combustion analyzer must be used for proper combustion analysis, operation, and to maintain peak efficiency
- Print out results to document your work

Solid fuel boilers:

- Thoroughly clean all interior combustion and flue passageways
- Inspect and clean chimney, flue piping, and anything used to transport exhaust gases
- Relief valves should be tested
- Test glycol for pH level
- Inspect door gaskets, controls, and circulators

Direct hot water – boiler generated

There are a number of boiler manufacturers that offer models which also heat potable water.

Some use a three-way valve to divert hydronically heated water through a flat-plate heat exchanger to produce hot potable water. The GPM flow rate is dependent upon net BTU input from the boiler (see tankless water heaters). During production of potable hot water, hydronic heating zones are disabled so the boiler's full energy is prioritized to making potable hot water. Temperature fluctuations and the potential for scalding make it important to use an ASSE 1016/1017 thermostatic scald-guard.

Other models have dual storage tanks – a tank within a tank – to maintain separation between the hydronic and potable waters. Heat-energy is transferred directly through the walls of the two tanks. A time-out feature can be programmed to temporarily shut down hydronic zones while domestic potable hot water is in use. While potable hot water outlet temperatures tend to be relatively stable, they will often be within scalding ranges, so be sure to use an ASSE certified 1016/1017 thermostatic scald-guard.

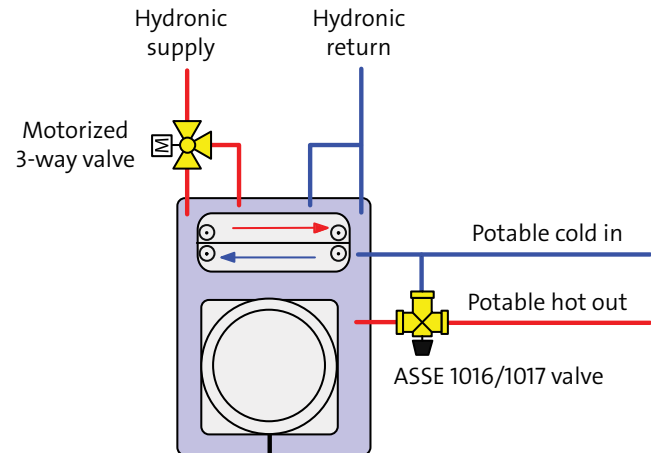

Indirect and direct water heaters

Basic indirect and direct storage-tank water heaters have a well insulated tank and lose very little heat to the surrounding area. Both types must be connected to an external energy source that generates heated water.

On average, an indirect tank has an internal coil through which hydronically heated water is circulated. A sensor or aquastat is used to monitor the storage temperature and activate/deactivate the external energy source. A properly sized circulator is used to move energy from the heat source through the tank's coil. The circulator should pump towards the highest head loss. GPH rating for heating potable water will be dependent on the GPM flow rate through the coil and the delivery temperature from (and net BTU rating of) the energy source.

On systems with a direct style storage tank, potable water is circulated through the energy-producing device to maintain temperature. All components must be rated for direct contact with potable water. Circulators must have bronze or stainless steel impellers and waterways and must be sized to meet the required GPM.

Meeting peak demand determines the sizing. As the storage tank volume increases, the net BTU rating of the heat source can be decreased. Multiple storage tanks can be combined with a single heat source to increase peak-demand storage.

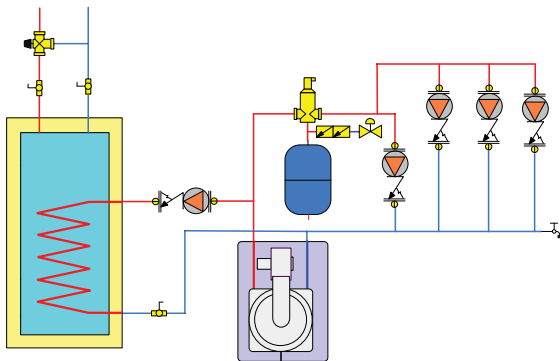

Tankless water heaters

Tankless water heaters heat water on-the-fly. If you apply the BTU ratings for the fuel type, know the ΔT and the appliance net input, the maximum delivery flow rate can be determined.

Things to know...

- Pressure drop may create the need for a booster pump
- Venting requirements must be followed exactly
- In retrofit applications, gas and electric lines must be increased
- Not suitable for use with aggressive or high mineral content water
- Direct recirculation is not recommended due to high head loss

⚠ Consult tankless manufacturer's recommendations before installing recirculation system.

- If an aquastat and timer is not used, the electric water heater may not have enough recovery rate to keep up with BTU losses.

Example: Indirect recirculation

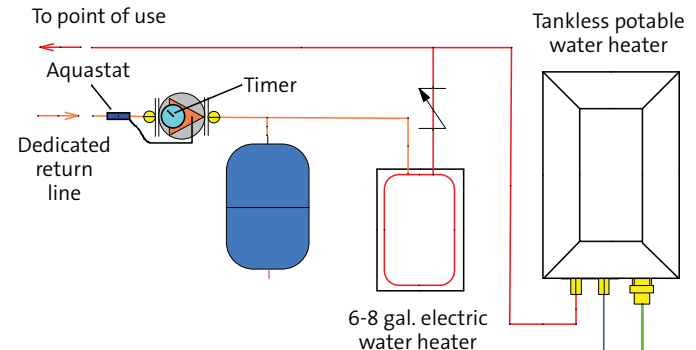

Solar hot water – storage tank

Three basic types of solar panels are the vacuum tube, flat enclosed panel, and soft roll mat. Vacuum tube array panels offer some of the highest efficiencies and potential for the hottest water (in excess of 160° F). Flat enclosed panels are less expensive and produce slightly lower temperatures, while soft roll mat panels are typically used for pool heating applications.

Common to all three: panels work best in a south-facing orientation. Storage volume is chiefly dependent on panel style, number of panels, solar radiation (amount of sunshine), lifestyles of the occupants, and other sources of hot water.

In warm climates where freezing is not a concern, the entire solar heat system (including the tank) may be located on the roof, or collectors may be lower in elevation than the storage tank. All other types will incorporate one or more circulators to move heated water.

In areas subject to freezing temperatures (solar panels can freeze at temperatures below 32° F), the solar heat system will either be pressurized and filled with a glycol/water mixture or self-draining to a tank that can accept the drained volume without overflowing.

Stored water is often above scalding temperatures. An ASSE-1016/1017 certified scald-guard mixing valve is required to regulate delivery temperatures. A differential temperature control turns the pump(s) on and off when the solar collector temperature rises above stored water temperature.

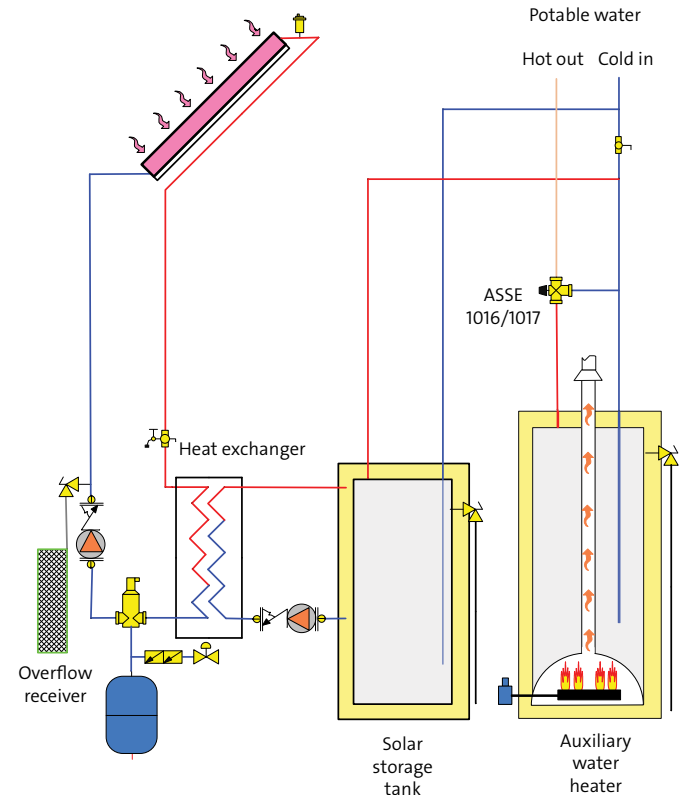

Basic piping strategies

Piping is used as the energy-transportation network. Its job is to permit sufficient flow to move enough heat within a given time frame, with velocities of 4 ft/sec or less so that comfort levels can be maintained under design conditions. Once you've calculated the heat loss, the design process and installation methods you choose will determine pipe sizing.

Manufacturers of pipe and tubing provide flow charts detailing maximum flow rates, fluid velocities and head loss per foot for various sizes.

Size matters: maximum tubing lengths are limited by flow rate and total head loss. If multiple loops are attached to a single manifold, the highest head loss of any single loop is the number used when selecting a pump to serve this manifold.

Circulators create a pressure differential that induces flow. The combined GPM flow rate required and single largest head loss determine which pump is the best match.



Pumping away

In any hydronics system, the point where the thermal expansion tank joins the piping is called the "Point of No Pressure Change." Since water cannot be compressed or stretched, no water can leave the hydronic loop when a pump starts/stops. Circulator pumps create a pressure differential when running, which upsets the pressure balance and causes fluid to flow. The pump's differential pressure will be added to the loop if it is installed after the thermal expansion tank – pumping away.

The added pressure causes air bubbles to shrink, which makes them less buoyant and helps carry them through the loop where they can be removed by an air elimination device such as an automatic air vent or separator. pumping away helps eliminate air, enhances quiet performance, and helps systems run more efficiently.

Warning: Pumping towards a thermal expansion tank has the opposite effect: pressure will decrease at the system's highest elevation, air bubbles will expand and gather together, noise will be created during operation, customers will complain, nuisance no-heat calls will occur, and the potential to damage system components will be present.

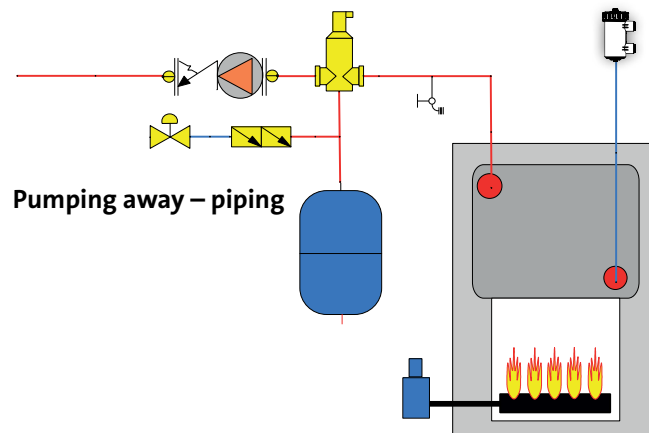

Primary, secondary, and tertiary loops

Primary loop:

This is normally the loop connected to the heat source with the thermal expansion tank. Multiple boiler configurations may each be connected to a primary loop (see boiler section for details).

Secondary loops:

These are connected to the primary loop and serve separate heating loads.

Tertiary loops:

These can be connected to secondary loops, as in the example below, where the return water temperature from the baseboard loop is the required supply temperature for the wall-panel radiator.

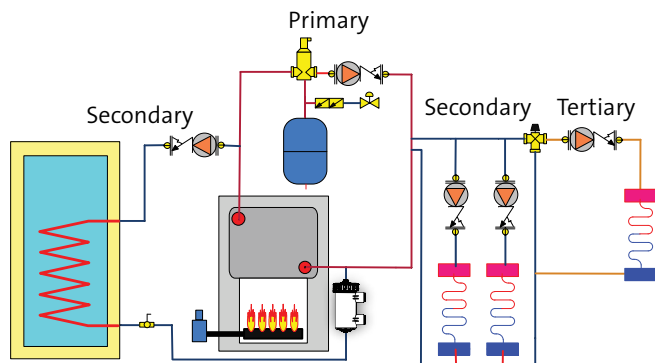

Series

All fluid passes throughout this network. Air elimination is critical at start-up and on a continuing basis in order to maintain comfort, quiet operation, and to protect system components.

Advantages:

- Simple
- Less expensive
- Easy control strategy

Disadvantages:

- Single zone only
- High head loss potential
- BTU drop-off along loop
- Flow rates critical
- Over/under heating

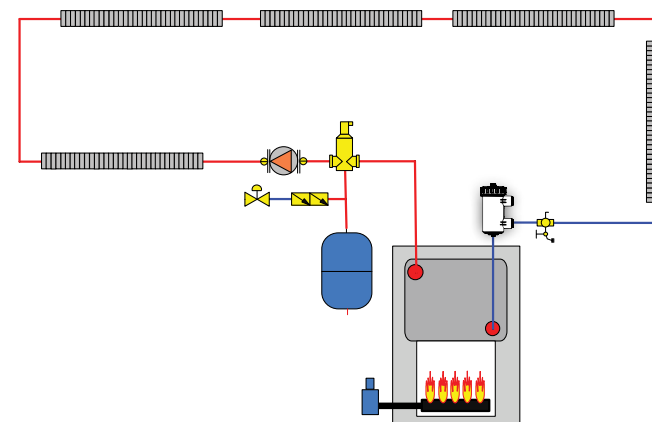

One-pipe distribution systems

Flow of water (BTUs) is accomplished by using tees with flow restrictors that cause some of the water to divert through the heat emitter.

2

Advantages:

- Reduced material cost
- Individual heat emitter control
- Enhanced heat distribution

Disadvantages:

- High head loss potential
- BTU drop-off along loop
- Flow rates very critical
- Air elimination difficult

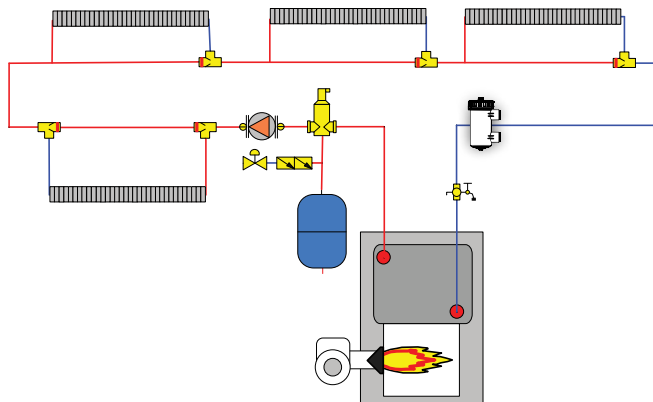

Parallel

Balancing for equal flow through parallel piping loops is accomplished by installing balancing valves or reducing/increasing pipe size in the supply/return lines.

2

Advantages:

- Simple
- Moderate cost increase
- Easy control strategy
- Individual heat emitter control
- Easy to balance heat output
- Consistent temperature supply

Disadvantages:

- High head loss potential
- Flow rates more critical
- Velocity noise
- Pipe sizing more critical

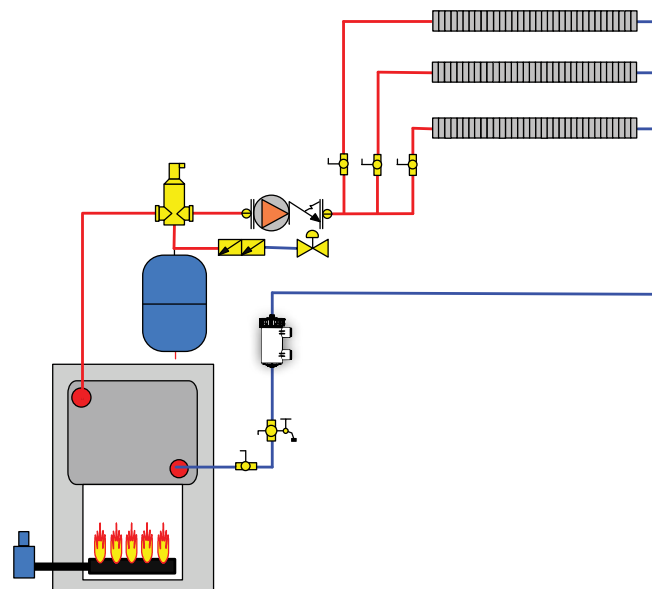

24

25

Two-pipe direct return

In a two-pipe direct return system, heat emitters are connected to the supply/return piping like rungs of a ladder.

2

Advantages:

- Simple
- Control heat emitters individually
- Zoning is possible

Disadvantages:

- Flow balance issues
- Uneven distribution of heat
- Velocity noise
- Over/under heating

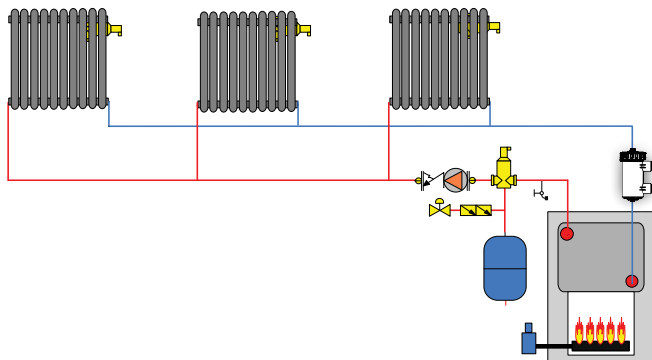

Two-pipe reverse return

In a two-pipe reverse return system, heat emitters are still connected between the supply return like rungs on a ladder. However, reverse return has its supply/return connected at opposite ends – pushing/pulling with equal force through all connected heat emitters that have identical or similar head losses.

2

Advantages:

- Simple
- Balanced heat output
- Quiet, even flow
- Individual zoning

Disadvantages:

- Higher cost
- May require a by-pass valve

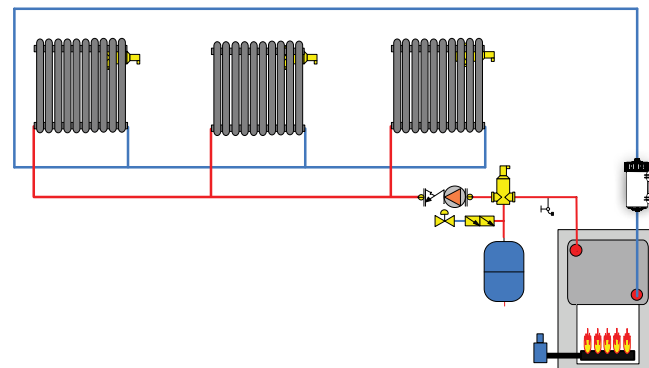

Zoning

Zoning can be accomplished by using circulators, motorized valves, manifold telestats, or solenoid valves, giving owners/occupants more control to manage room-to-room comfort levels. Zoning reduces energy consumption by heating only spaces during operator-programmed time periods.

2

Advantages:

- Reduced energy cost
- Independent control of space
- Design flexibility

Disadvantages:

- Higher installation cost

Example 1:

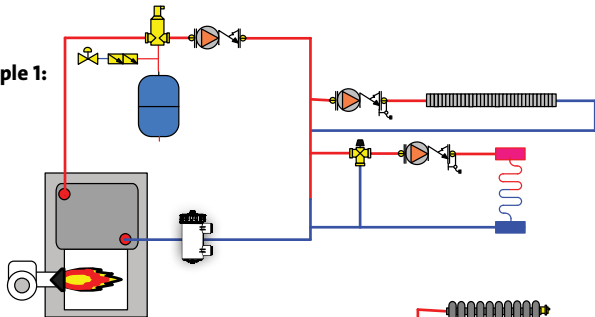

Example 2:

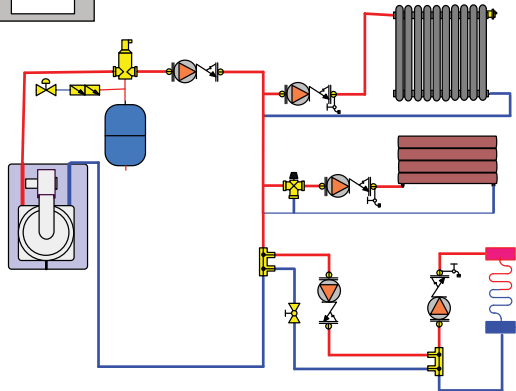

28

Zone pumping

Today's compact wet-rotor circulators are extremely versatile, rugged and reliable.

Multi-speed circulators allow the designer or installer to adjust flow rates for reduced energy consumption and silent operation.

ECM circulators can be energy efficient and deliver variable performance depending upon your control strategy.

Adding air purge and isolation flanges and air elimination can be simple. Servicing a single circulator is quickly accomplished without interrupting the operation of other zones.

Zoning with circulators offers the ability to deliver multiple temperatures from either a single-source set-point or graduated temperatures from a primary loop with outdoor reset. As the reset curve changes, the mixed-down temperatures will allow the secondary circuits to use the same reset ratio. The highest temperature zone becomes the reset target temperature and determines the reset ratio.

Note:

The UPSe 15-58 and ALPHA 15-58 can be set to Zone Pump mode, which is constant curve. Available only on the ALPHA 15-58, you can also select AutoADAPT mode for optimum energy savings, and you can use the Grundfos GO app to further commission the pump to customize the circulator settings.

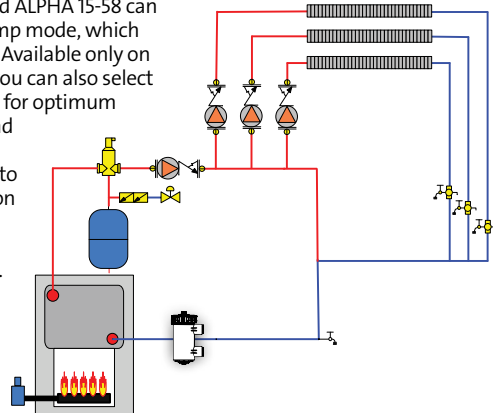

2

29

Zoning with valves

Properly sizing a circulator includes totaling all zone-connected circuit GPM flow rates and the single greatest resistance to flow in any of the connected circuits. As zone valves open/close, the flow rates and fluid velocities vary. Most zone valves need to close against flow to avoid slamming shut.

In order to avoid flow and velocity-related noises, a differential bypass regulator may be needed. As valves close and head increases, the bypass regulator opens to maintain proper flow/velocity.

The UPSe 15-58 and ALPHA 15-58 can be set to Zone Valve mode, which is constant pressure. Available on the ALPHA 15-58, you can also select AutoADAPT mode for optimum energy savings, and you can use the Grundfos GO app to further commission the pump to customize the circulator settings. AutoADAPT mode will adjust its flow according to system demand. As valves close, flow demand and therefore flow will decrease, eliminating the need for a by-pass relief valve. This represents better system control and significant cost savings.

Circuits can be quickly charged by installing a purge valve on the main return or on individual returns to eliminate air. A single purge fitting can be used to quickly charge all zones.



Advantages:

- Manifold zoning
- Less expensive

Disadvantages:

- Wiring can be difficult
- May require larger transformer
- Frequent replacement
- System debris failure
- Drain system to replace
- Frequent leaks

Note:

If an ALPHA 15-58 or ALPHA2 26-99 is used for this application the by-pass relief valve assembly is not required.

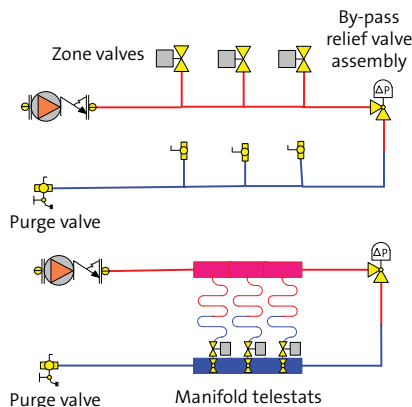

Injection piping

Injection piping serves as a thermal bridge between two circuits for transferring BTUs. Being hydraulically separated, the primary and secondary circuits can have varying flow rates with no effect on the other. The injection bridge circuit can also operate at a different flow rate. If the ΔT is allowed to widen, more BTUs can be transferred over the injection bridge at lower flow rates. With low flow rates required to transfer large amounts of energy, the injection bridge will allow manifolds serving large areas to be remotely located, away from the mechanical room.

Note 1: Reduced diameter injection piping (supply and return).

Note 2: There must be a maximum of 6 pipe diameters between the tees in the boiler and system loops in order to prevent heat migration (ghost flow).

Note 3: There must be at least 6 pipe diameters of straight pipe on either side of the tees in order to prevent turbulent flow which could encourage heat migration.

Note 4: To prevent heat migration through the injection loop, there should be a minimum 18-inch drop to create a thermal trap.

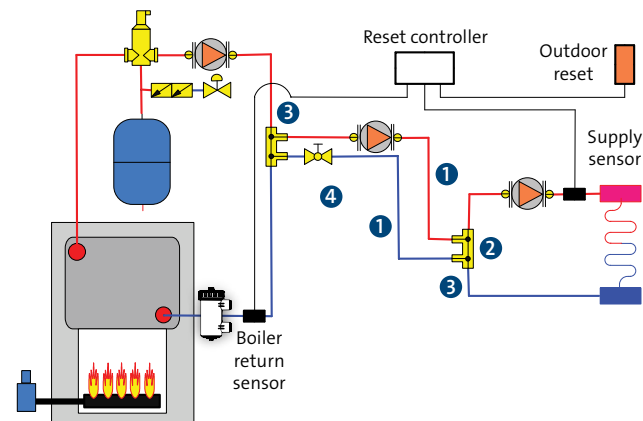

Grundfos ALPHA range piping strategies

The addition of the ALPHA2 26-99, with 8 intelligent control functions, has expanded the performance range of the proven ALPHA technology to a maximum of 26 GPM and 42 ft of head.

The ALPHA 15-58 and ALPHA2 26-99 in AutoADAPT function will automatically analyze the heating system, find the optimum system curve and duty point and continually adjust to meet changes in demand.

The ALPHA, featuring a constant-pressure, proportional-pressure and constant-speed curve – each with three speed settings as well as an AutoADAPT setting – is suitable to replace a standard 3-speed pump and will deliver 50% energy savings of the ECM motor and adjust flow to demand.

The Grundfos ALPHA line of pumps with its wide performance range will replace many models of standard circulators thus reducing inventory requirements.

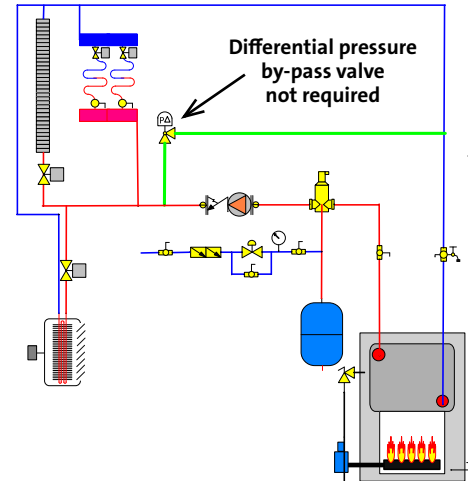
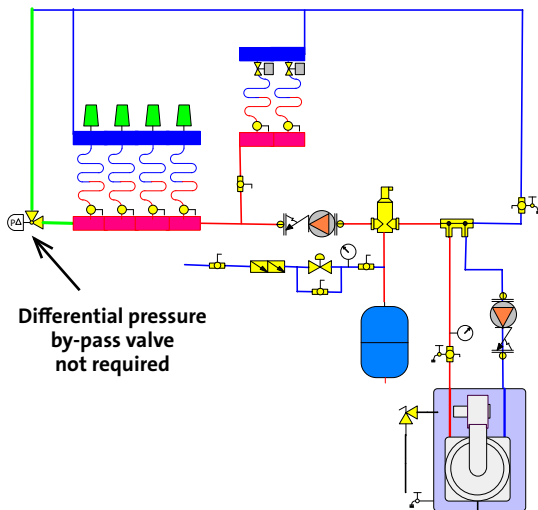

Using the ALPHA 15-58 or ALPHA2 26-99 pump in a controlled mode, will eliminate the need for differential pressure by-pass valves.

Constant pressure, or AutoADAPT mode, will automatically adapt to meet the demands of your heating system. By measuring and analyzing power demands, pumping speeds are adjusted to maximize comfort levels and energy consumption.

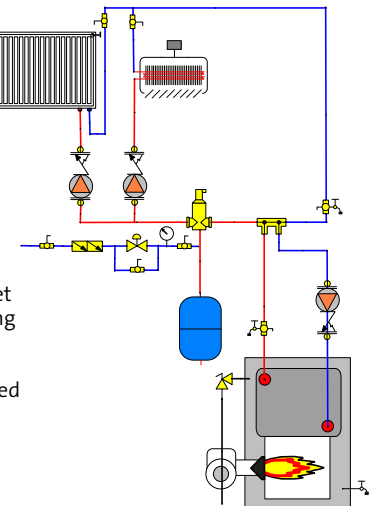

Radiant heating

In a radiant heating application, liquid is pumped through distribution piping, providing heat to be transferred to floors, walls, or ceilings. These surfaces radiate heat in all directions, with warmth always moving to colder, solid objects.

The water temperature for radiant heating systems is typically much lower than what's used with other types of heat transfer – such as with radiators and baseboard systems. Putting heat where it's most needed and the use of lower liquid temperatures improve comfort, control, and reduce energy consumption.

It's not uncommon for a radiant system to vary its water delivery temperatures from 75° F to 140° F to offset building heat losses. During the heat loss calculation and design phase, a reset ratio is calculated to determine the upper and lower water delivery temperature limits. Floor surface materials must be considered and will affect the rate of heat transfer.

Multi-speed, low-wattage circulators, like the SuperBrute, give you greater flexibility to match wide varieties of required flow/head rates for floor, wall, and/or ceiling applications.

There are a number of installation methods for radiant heating applications. Each one provides varying degrees of energy efficiency and comfort. The correct application will be the one that most closely matches a given installation and its design.

The finished surface materials will determine maximum allowable water temperatures.

Concrete slab installations

Tubing layouts vary widely. The intent, ideally, is to run the warmest water along the coldest sides first. Rooms with a single exposed wall might be served by a simple back-and-forth serpentine loop. For long walls or multiple exposed walls, two loops (or more) can be run in a counter-flow pattern with each loop's water flowing in opposite directions to minimize any noticeable floor temperature difference.

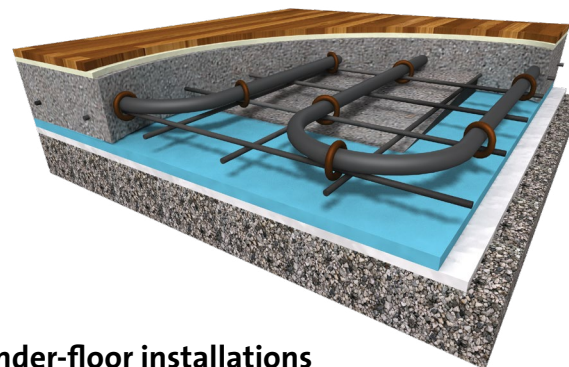

Under-floor installations

There are four basic types of installation for under-floor designs: suspended tube, staple-up, thin plate, and extruded plate. Thermal performance varies between each style. Insulation installed below the tubing directs heat upward through the flooring materials.

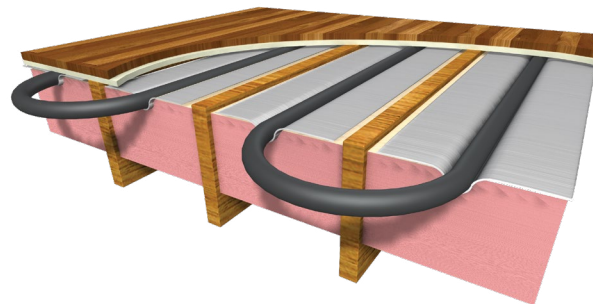

Above-floor installations

There are four basic installation applications for above-floor designs: staple-down with gypcrete over-pour, plated tube on sleepers, structural sub-floor with built-in tube channels, and several non-structural, over-floor products with channels for tubing.

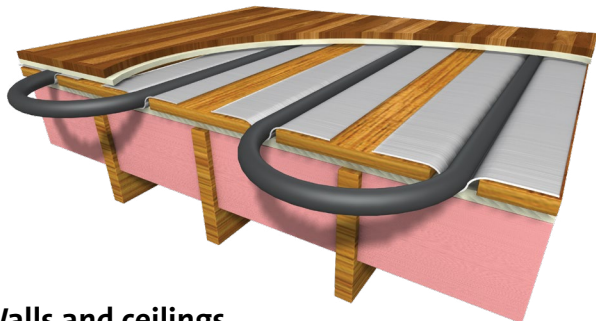

3

Walls and ceilings

In some installations, it may be necessary or desirable to run tubing in walls or ceilings to offset heat loss. For a walk-in shower, for instance, it may be best to heat all surfaces for a warm cocoon-like environment. Towel warmers can also be used to provide a portion of the heat load.

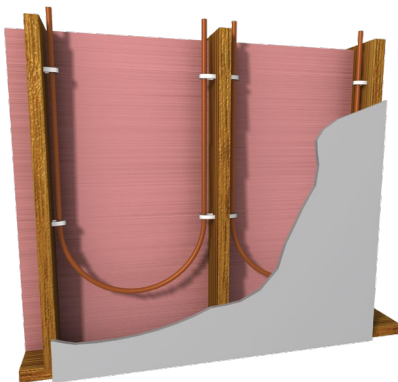

36

Snow melt

Snow melting systems are a popular addition to hydronic systems. In some cases, the snow melting load will be far greater than the home or business heating needs. This may mean installing a separate stand-alone heat source for snow melting. Glycol solutions are more viscous than plain water, which increases head (resistance to flow) and also slightly reduces the ability to transport heat energy.

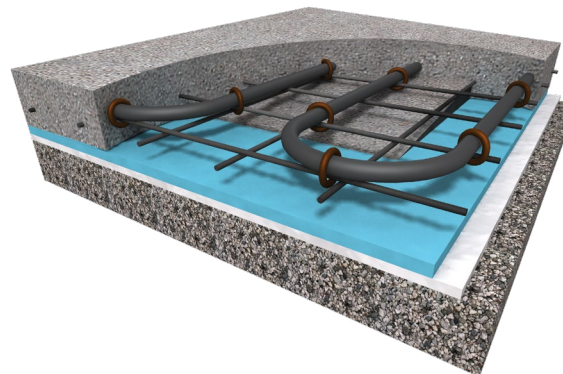

3

Be sure to check insulation requirements for slab-on-grade installations.

Please review applicable building codes, permit requests, and other laws governing radiant heating systems to ensure your installation design is compliant.

37

Snow melting

Snow melting systems are sometimes required for safety in public areas and helipads at hospitals. Residential snow melting systems are a popular addition to hydronic systems. In some cases, the snow melting load will be far greater than the home or business heating needs. This may mean installing a separate stand-alone heat source for snow melting. Or, for a swimming pool, you could offer temperature conditioning to extend the swimming season.

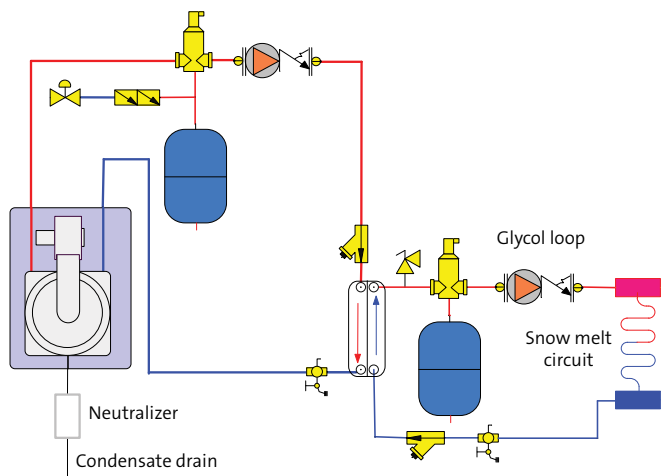

Liquid glycol solutions are more viscous than plain water, which increases head – resistance to flow – and also slightly reduces the ability to transport heat energy (see glycol information in the pumping section). Condensing modulating boilers are often used for these low-temperature applications because they do not require boiler flue gas condensation or thermal shock protection. Hydronic glycol pH should be tested annually. Thermal expansion is greater when glycol is added and the expansion tank must be rated for use with glycol.



3

3

Determining metallurgy

An important aspect of pump selection should be determining the metallurgical makeup of your circulator. Pump application, fluid medium, and local governing standards are important factors to consider when selecting the pump.

Heating systems are typically closed, hermetically sealed piping systems. In most cases, fresh water is never required after commissioning; the system is pressurized and there is no interaction with the atmosphere. These factors tend to limit corrosion caused by oxygen. However, in some circumstances such as the use of wood-fired boilers, an open system is used for heating. In this case, a bronze or stainless steel pump should be used to reduce corrosion.

The type of fluid being pumped by the system is also important to consider; different liquids such as glycol, freshwater or chemicals can have different corrosion effects on different types of metals.

Lastly, it is important to defer to any federal, state, or local standards governing metallurgy.

In most residential hydronic heating systems, corrosion is limited and cast iron is the metallurgy commonly chosen when selecting a circulator. In special operating circumstances, a different metallurgy may be required due to aggressive chemicals or harsh pumping conditions.

The following parameters may influence your metallurgical selection

- Aggressive carbon dioxide
- Free chlorine (CL₂)
- Oxygen (O₂)
- Acidity (pH)
- Chloride (CL)
- CO₂
- Hydrogen sulphide (H₂S)
- Temperature

Common metallurgy available with corrosion resistance increasing left to right.



Cast iron -> Bronze -> Stainless steel

Static, dynamic, & total dynamic head

The term “head” is used often and has many different meanings – no wonder it’s confusing. Let’s untangle the head knot a bit.

Static head:

Defined as the pressure required to adequately fill the hydronic system. Static head needs to be greater than the highest elevation within the hydronic system.

One PSI will cause water contained in a column to rise 2.31 feet. You’ll often see the rise in feet shown as ‘altitude’ on gauges. 12 PSI = 27.72-feet of static pressure. Static head does not relate to the selection of circulators.

Dynamic head:

Defined as one half of the required information to properly select circulators. Hydronic systems move liquid containing heat energy from the heat source to all points where warmth is needed. Pressure-energy is exerted by circulators to meet or exceed resistance to flow (dynamic head) to move the liquids at the required GPM. The pathway from heat source to areas where heat is needed (or points of comfort) and back again creates a loop.

Within each loop, there are multiple sources of friction that create resistance to flow (dynamic head). Look for the one component that has the highest resistance to flow. Examples: longest single length of PEX connected to a manifold; mixing valve; total developed length of supply/return piping; heat emitters; or monoflow tees. As GPM flow rates change, the dynamic head will also change.

Total dynamic head:

Each component through which hydronic fluid passes has a specific “dynamic head.” This number will increase or decrease as flow rate increases or decreases. Once you know the GPM flow rate, you need to determine total dynamic head – often expressed as “head losses” or “feet of head,” a number derived by adding the various dynamic head losses for all components in that loop.

GPM rates, along with total dynamic head, are the two factors used when selecting circulators (see next page).

Selecting the right circulator made easy

By now, you have completed several steps along the path to selecting the best circulator that will use the least amount of energy to overcome dynamic head.

The heat loss, fluid temperature, and potential BTU output of the heat emitter(s) determine GPM flow rates, which guide you toward circulator selection. In the following examples, we'll use the UPS15-58. You will see three colored bands that represent three different speed ranges (high-med-low). Reference the dotted lines for applications when integral flow-checks are required.

Example 1:

At 1 GPM and 140° F fluid temperature, head losses for the 3-way valve is rated at 15.5 feet, piping 1 foot, and radiator 2 feet. Find the intersecting points for 18.5 feet of total dynamic head and 1 GPM. High speed is correct.

HIGH SPEED

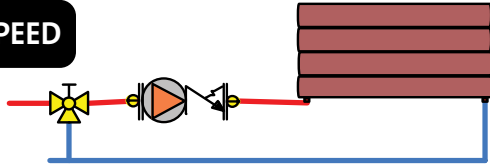

Example 2:

Assume a total flow requirement of 5.6 GPM (1.4 GPM per loop). Head loss 5/8-inch Pex @ 1.4 GPM = .03 per foot. 350 feet of Pex x .03 = 10.5 feet of head. Find intersecting point for 10.5 feet of total dynamic head and 5.6 GPM. Medium speed is correct.

MED SPEED

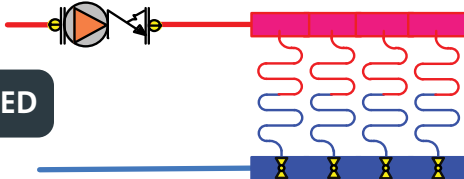

Example 3:

Head loss 3/4 inch copper = .04/100 ft. @ 170°F. 150 feet total equivalent length; 150 x .04 = 6 feet of dynamic head and 4 GPM is required. Find the intersecting points for 6 feet of total dynamic head and 4 GPM. Low speed is correct.

LOW SPEED



UPS15-58F/FC performance curves

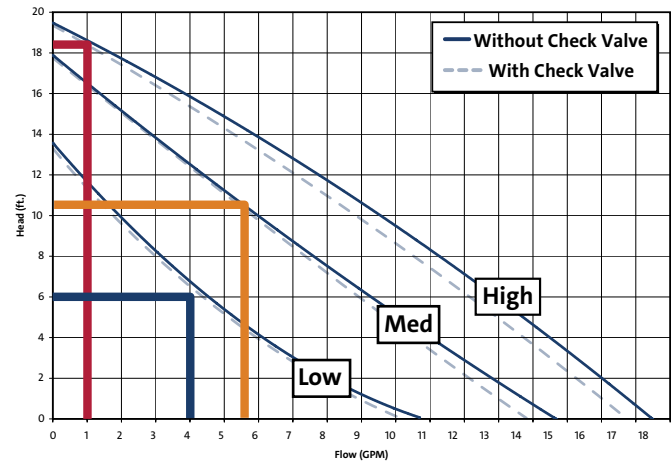

Circulator pump energy rating label

– Big steps towards greater sustainability

Homes and businesses rely on circulators to operate heating, cooling, and domestic hot water systems. The Energy Rating label provides a clear and easy way to identify energy-efficient circulators and a range of potential savings. The higher the Energy Rating, the more savings the circulators can provide the end user. Labeled circulators provide:

- Optimized performance
- Improved comfort
- Reliable quiet operation
- Fully integrated controls
- Qualifies for utility rebates
- Easy drop-in upgrade
- Trusted performance data
- Tested to industry standards
- Broad industry participation

Reading the Energy Rating label



Brand XYZ
WAIP: 0.068

Model #: ABC123

CIRCULATOR PUMP **CEI: 0.60 (ER 180)**

ENERGY RATING

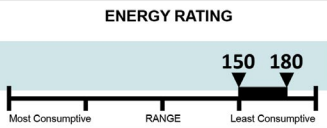

Note: The ER value is dependent on the selected control. Multiple options may be available on this pump, as follows:

<ul style="list-style-type: none"> • Full Speed • Manual Speed • External Input Signal 	<ul style="list-style-type: none"> • Pressure (Rated) • Temperature
---	---

Power savings (watts) over a baseline case can be estimated by multiplying the ER by WAIP and multiplying by 7.46. Multiplying power savings by operating hours and cost of energy will yield estimated cost savings.

Q45RTE er.pumps.org Jun 2021

1. Basic Information
Pump brand, model number, weighted average input power (in horsepower) for a baseline ECM circulator.

2. Circulator Energy Index (CEI)
Rating index comparing power consumption to a traditional circulator. Lower values are better.

3. Energy Rating
Rating indicating the percent power savings over a traditional circulator. The higher the energy rating, the greater the savings. The range represents the most and least consumptive available control modes.

4. Available Controls
Shows available control methods.

5. Estimated Savings
Illustrates the method for using the ER rating to determine actual savings.

Grundfos UPSe & ALPHA product range

Capable of replacing more than 40 other pump models, the UPSe and ALPHA circulator range features the highest starting torque along with the highest energy rating in its class. The UPSe delivers constant pressure, proportional pressure, and constant curve, each with three speed settings. The ALPHA builds on these capabilities with the addition of an AutoADAPT setting, removing the need to manually select the pump setpoint. Together with the Grundfos GO app, the ALPHA also provides the ability to conveniently troubleshoot your system through the event log, run guided setup, set custom control modes, and run firmware updates. Historical trend data for flow, head, media temperature, and on-cycle durations are also available through the app.

PRODUCT FEATURES	UPSe	ALPHA	ALPHA1 26-99	ALPHA2 26-99
ECM Energy Efficient Motor	X	X	X	X
3 Constant-Speed Modes	X	X	-	-
3 Constant Pressure Modes	X	X	-	X
AutoADAPT Control Mode	-	X	-	X
Proportional Pressure	X	X	-	X
Guided Commissioning	-	X	-	-
Self-Venting	X	X	-	-
0-10V Analog Input	-	-	X	-
Communicate via Grundfos GO	-	X	-	-
Dry-Running Protection	X	X	-	-
Starting Torque [mNm]	360	360	360	360
Max. Head [Feet]	19	19	42	42
Max. Flow [GPM]	13.6	13.6	26	26
LED Display	X	X	-	-
System Air Detection/Venting	-	X	-	-
Terminal Box Connection	X	X	X	X
Cast-Iron Pump Housing	X	X	X	X
Toolless Power Connector	X	X	-	-

UPSe

– Energy efficient circulator



Technical data

Flow range:	0 - 13.6 GPM
Head range:	0 - 19 Feet
Motor:	1 x 115V
Watts:	3-38 W
Fluid temperature range:	36°F (2°C) to 230°F (110°C)
Max. working pressure:	175 PSI
Amps:	0.70 A
Flange-to-flange-length:	6-1/2"
Pump housing:	Cast iron
Connection type:	Flanged, with terminal box
Energy rating:	193
Approvals:	cULus and FCC

Control features

The pump features a wide range of controls, including constant pressure, proportional pressure, and constant curve, each with three settings, making it suitable for almost any hydronic application.

Performance curves

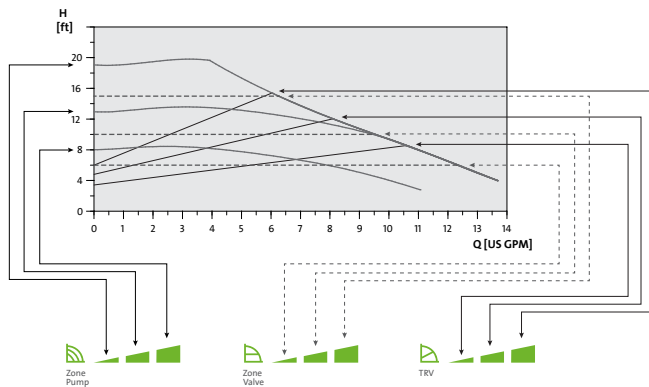

ALPHA

– Fully digital, energy efficient circulator



Technical data

Flow range:	0 - 13.6 GPM
Head range:	0 - 19 Feet
Motor:	1 x 115V
Watts:	3-38 W
Fluid temperature range:	36°F (2°C) to 230°F (110°C)
Max. working pressure:	175 PSI
Amps:	0.70 A
Flange-to-flange length:	6-1/2"
Pump housing:	Cast iron
Connection type:	Flanged, with terminal box
Energy rating:	193
Approvals:	cULus and FCC

AutoADAPT control mode:

This function controls pump performance automatically within a defined performance range. Ensuring the lowest possible energy consumption, while maintaining maximum comfort levels.

Intuitive digital troubleshooting:

Identify pump problems with the Grundfos GO app. Simply connect to the pump via Bluetooth to understand and fix issues, as well as access historical trend data.

Performance curves

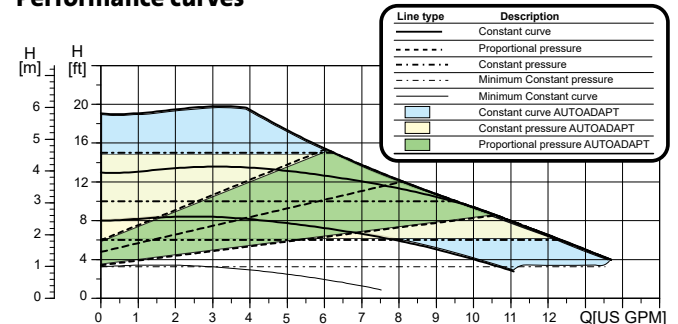

ALPHA1 26-99

– Variable speed circulator with 0-10V analog input

Technical data

Flow range:	0 - 26 GPM
Head range:	0 - 42 Feet
Motor:	1 x 115V
Watts:	3-120 W
Fluid Temperature range:	14°F (-10°C) to 230°F (110°C)
Max. working pressure:	150 PSI
Amps:	0.70 A
Flange-to-flange length:	6.5"
Pump housing:	Cast iron
Connection type:	Flanged, with terminal box



ALPHA2 26-99

– Variable speed circulator with eight intelligent control modes

Technical data

Flow range:	0 - 26 GPM
Head range:	0 - 42 Feet
Motor:	1 x 115V
Watts:	3-120 W
Fluid temperature range:	14°F (-10°C) to 230°F (110°C)
Max. working pressure:	150 PSI
Amps:	0.70 A
Flange-to-flange length:	6.5"
Pump housing:	Cast iron
Connection type:	Flanged, with terminal box



Proportional pressure AutoADAPT & constant pressure AutoADAPT:

AutoADAPT functionality enables the ALPHA2 26-99 to control operation automatically within a defined performance range. When set in proportional pressure AutoADAPT or constant pressure AutoADAPT, the pump will automatically analyze the heating system, find the optimum system curve and duty point and continue to adjust its operation to changes in demand, consumption, while maintaining maximum comfort levels.

0-10V analog input

Featuring a 0-10V analog input for speed control and an alarm output signal, allowing easy boiler and building management integration. A magnetite-resistant design, robust ceramic shaft and stainless-steel bearing plate ensure that the ALPHA1 26-99 reliably delivers the optimal system flow at the lowest possible energy consumption.

Performance curves

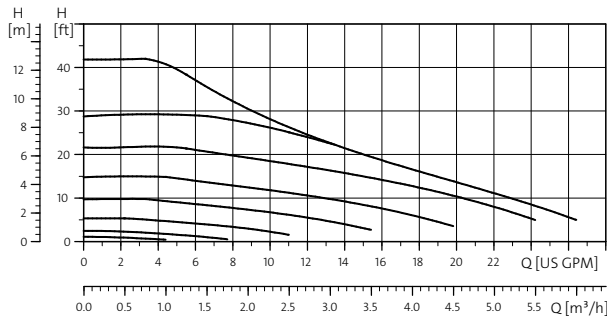

Performance curves

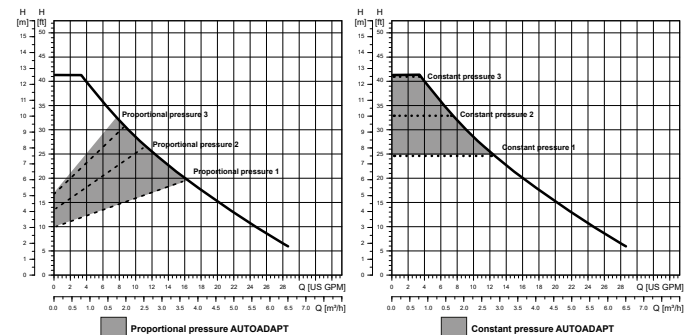

UPS15-58⁽¹⁾, 26-99⁽²⁾, 43-44⁽³⁾
3-speed pump
 – for heating systems



Technical data

Flow range:	0 - 64 GPM
Head range:	0 - 30 Feet
Motor:	1/25 Hp ⁽¹⁾ , 1/6 Hp ^(2,3)
Voltage:	1 x 115V ^(1,2,3) , 230V ^(2,3)
Fluid temperature range:	36°F (2°C) to 230°F (110°C)
Max. working pressure:	145 PSI
Flange-to-flange length:	6-1/2 inches ^(1,2) , 8-1/2 inches ⁽³⁾
Pump housing:	Cast iron ^(1,2,3) , bronze ^(2,3)
Pump connection type:	(2) 1/2" dia. bolt holes (GF 15/26) (2) 1/2" dia. bolt holes (GF 40/43)

• Standard features:
Removable check valve

UPS26-150⁽¹⁾, 43-100⁽²⁾, 50-60⁽³⁾
3-speed pump
 – for heating systems



Technical data

Flow range:	0 - 120 GPM
Head range:	0 - 47 Feet
Motor:	1/3 Hp
Voltage:	1 x 115, 230V
Fluid temperature range:	36°F (2°C) to 230°F (110°C)
Max. working pressure:	150 PSI
Flange-to-flange length:	6-1/2 ⁽¹⁾ , 8-1/2 inches ^(2,3)
Pump housing:	Cast iron, Stainless steel
Pump connection type:	(2) 1/2" dia. bolt holes (GF 15/26) ^(1,2) (2) 1/2" dia. bolt holes (GF 40/43) ⁽²⁾ (4) 1/2" dia. bolt holes (GF 50) ⁽³⁾

Performance curves

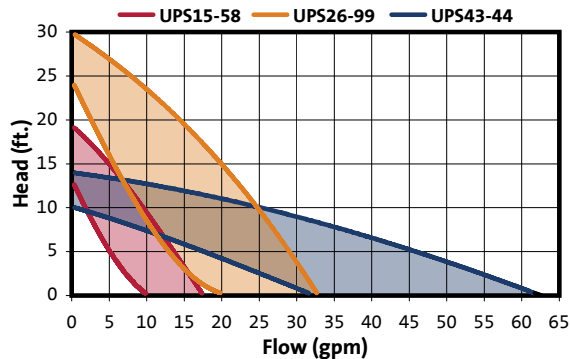

Performance curves

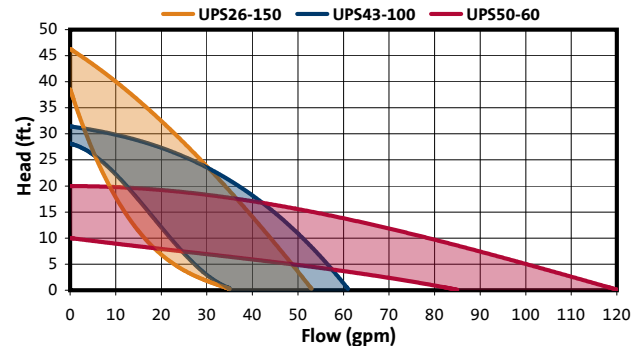

MAGNA product range

The energy-efficient MAGNA range covers virtually all system requirements and makes the installation and commissioning of commercial heating and cooling systems easier than ever. The MAGNA1 is a highly-efficient, high-performance circulator designed for pumping liquids in systems where the MAGNA3 offers advanced communication features via GO Remote, and building management systems, all while delivering control features including AutoADAPT, FlowADAPT and differential temperature control.



MAGNA3

– Intelligent variable speed circulator



Technical data

Flow range: 0 - 484 GPM (Dual Head)
 Head range: 0 - 60 Feet
 Motor: 11 x 115V, 115-230V & 208-230V, 50/60 Hz
 Fluid temperature range: 14°F (-10°C) to 230°F (110°C)
 Max. working pressure: 175 PSI
 Pump housing: Cast iron, Stainless steel
 Connection type: Flanged, with terminal box

PRODUCT FEATURES	MAGNA1	MAGNA3
ECM energy efficient motor	X	X
3 constant-speed modes	X	X
3 constant pressure modes	X	X
AutoADAPT control mode	-	X
FLOWAdapt control mode	-	X
Proportional pressure	X	X
Differential or constant temp.	-	X
Communicate via Grundfos GO	-	X
Communicate with BMS	-	X
Starting torque [mNm]	360	360
Max. head [Feet]	59	60
Max. flow [GPM]	313	484
Display	LEDs	Graphic Display
Multipump	-	2 Pumps
Terminal box connection	X	X
Cast-iron pump housing	X	X
Stainless steel pump housing	X	X
Insulation shell	-	X

Performance curves

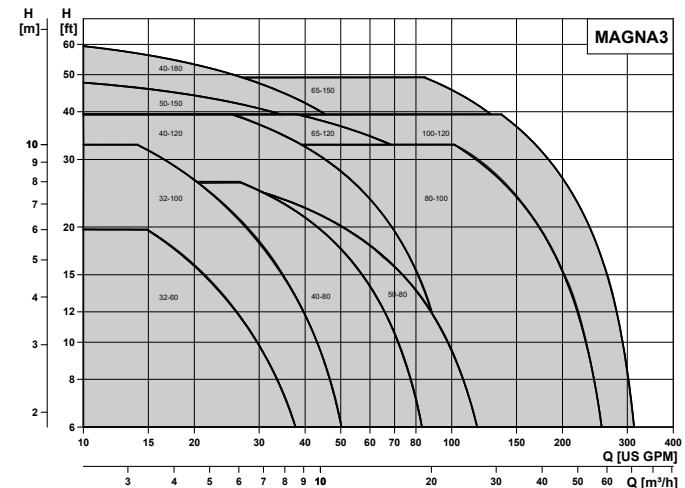

MAGNA3 control feature - AutoADAPT

This control feature is recommended for most dynamic heating systems, continuous changes in head and/or flow requirements, and especially for distribution systems with relatively large pressure losses. A form of proportional-pressure control, the duty point has to be within the AutoADAPT operating range. During operation, the pump automatically makes the necessary adjustments to the actual system characteristics. This feature ensures minimum energy consumption – lower operating costs, reduced piping noise, and constant comfort levels.

When the AutoADAPT control mode is enabled, the pump will start with factory setting, $H_{fac}=H_{set1}$, corresponding to 55% of its maximum head, and then automatically adjust its performance to A1.

When the pump registers a lower head on the maximum curve, A2, the AutoADAPT function automatically selects a corresponding lower control curve, Hset2. If the valves in the system close, the pump adjusts its performance to A3.

- A1:** Original duty point
- A2:** Lower registered head on the maximum curve
- A3:** New duty point after AutoADAPT control
- Hset1:** Original set-point setting
- Hset2:** New set-point after AutoADAPT control
- Hauto_min:** A fixed value of 5 ft (1.5 m)

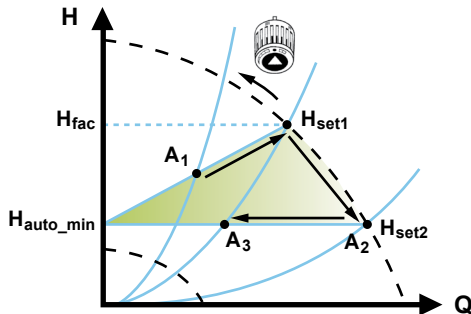

Learn more at grundfos.us/magna3

MAGNA3 control feature – proportional pressure

This control mode is used in systems with relatively large pressure losses in distribution piping. The head of the pump will increase proportionally to the flow to compensate for the large pressure losses. The set-point can be set with an accuracy of 0.5 feet.

Two-pipe heating systems with thermostatic valves and

- very long distribution pipes
- throttled pipe balancing valves
- differential-pressure regulators
- large pressure losses through boiler, heat exchanger, and distribution piping

Primary circuit pumps in systems with large pressure losses in the primary circuit.

Air-conditioning systems with

- heat exchangers (fan coils)
- cooling ceilings
- cooling surfaces

The head against a closed valve is half the set-point Hset.

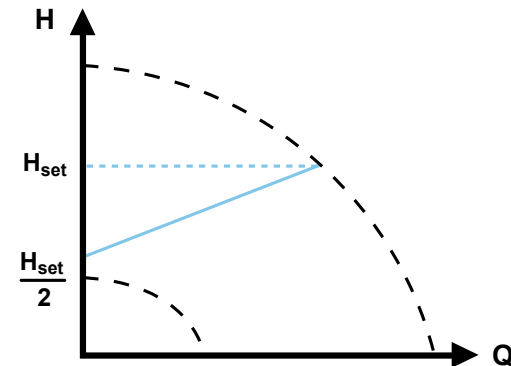

MAGNA3 control feature – constant pressure

Recommended use in systems with relatively small pressure losses in distribution piping. The pump head is kept constant, independent of the flow in the system.

- Two-pipe heating systems with thermostatic valves and
- dimensioned for natural circulation
 - small pressure loss boilers, heat exchangers, and distribution piping
 - moderate to high differential temperature between supply and return piping (for example, district heating)
 - Underfloor heating systems with thermostatic valves
 - One-pipe heating systems with thermostatic or pipe-balancing valves
 - Primary circuit pumps in systems with small pressure losses in the primary circuit

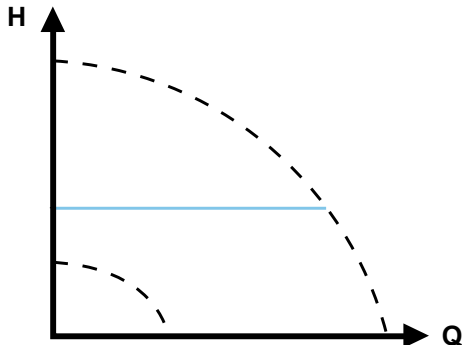

MAGNA3 control feature – constant curve

The pump can be set to operate according to a constant curve. If an external controller is installed, the pump is able to change from one constant curve to another, depending on the value of the external signal.

The desired speed can be set as % of maximum speed in the range from 25 to 100%.

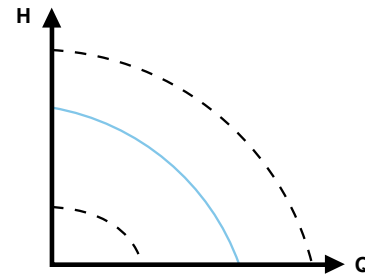

The pump can also be set to operate according to the maximum or minimum curve, like an uncontrolled pump:

- The maximum curve mode can be used for hot-water priority.
- The minimum curve mode can be used for manual night setback if automatic night setback is not desired

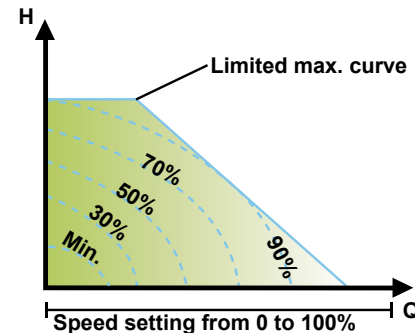

MAGNA3 control feature – constant temperature

In heating systems with a fixed system characteristic, for example domestic hot-water systems, the pump would maintain a constant return temperature.

If the pump is installed on the supply side of piping, an external temperature sensor must be used on the return piping of the system. The external sensor must be installed as close as possible and on the exit side of the heat exchanger.

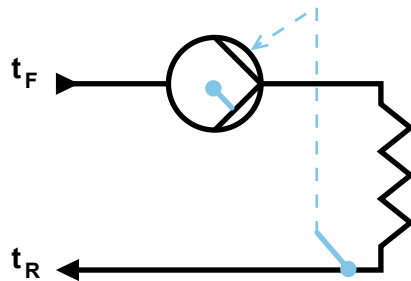

If the pump is installed on the return piping, the internal sensor can be used. The pump should be installed as close as possible to the heat exchanger.

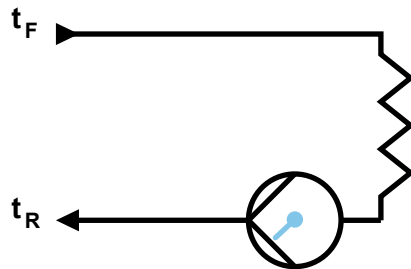

MAGNA3 control feature – differential temperature

This control mode ensures a constant differential temperature drop across heating and cooling systems. The pump will maintain a constant differential temperature between the pump and the external sensor.

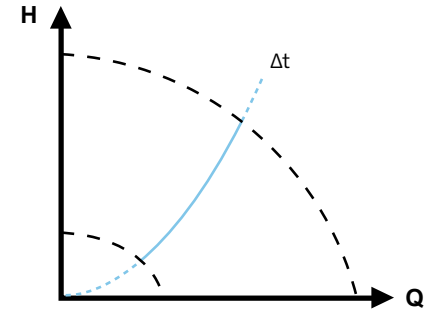

If the pump is installed on the return piping, the internal sensor can be used. The pump should be installed as close as possible to the heat exchanger.

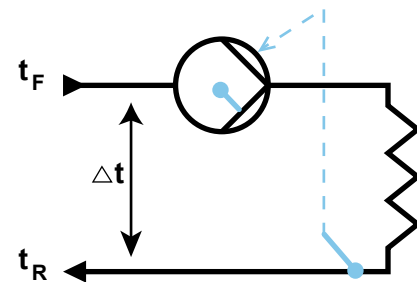

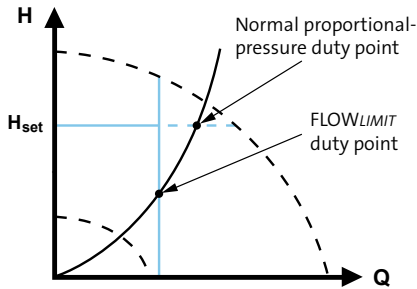

MAGNA3 control feature – Automatic Night Setback

Once the Automatic Night Setback has been enabled, the pump automatically changes between normal duty and night setback. Changeover between normal duty and night setback depends on the flow temperature. The pump automatically changes over to night setback when the built-in sensor registers a flow temperature drop of more than 18-27°F within approximately 2 hours. The temperature drop must be at least 1.8°F/min.

Changeover to normal duty takes place without a time lag when the fluid temperature has increased by approximately 18°F.

Note: Automatic night setback cannot be used when the pump is in constant curve mode.

TPE3

– Intelligent and efficient in-line pump

Technical data

Flow range:	0 - 350 GPM
Head range:	0 - 80 Feet
Motor:	200-240V, 380-500V, 50/60 Hz
Fluid temperature range:	14°F (-25°C) to 230°F (+140°C)
Max. working pressure:	230 PSI
Pump housing:	Cast iron, stainless steel
Connection types:	Flanged, with terminal box

- Front-mounted wiring box
- Multipump: duty/standby – 2 pumps, cascade – 2 to 4 pumps
- Single-screw clamp ring for pump head adjustment
- Grundfos GO gives you intuitive handheld pump control and full access to Grundfos online tools. This is also possible via the pump's display
- Grundfos Eye visual status indicator
- Hassle-free insulation with clip-on tailor-made shells around the pump (accessory)

TPE3 provides unrivaled efficiency and a wide range of intelligent functionalities that make it more than a pump.



Built-in heat energy monitor for complete control

The TPE3 has a built-in heat energy monitor as well as a flow-limiting function that eliminates the need for a pump throttling valve.

- Measure current energy consumption, flow rate, and much more
- Avoid the cost of installing a separate heat energy metering device within your system
- Integration with BMS gives you a quick overview of the performance of your system (available as extra functionality)
- Can be used in a wide range of applications, from ground source heat pumping and solar to more traditional applications like heating and cooling

Performance curves

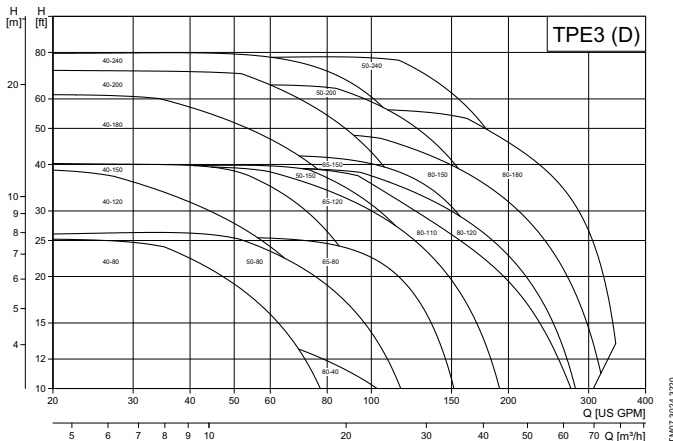

Large UP – Single speed circulator

UP43-70 (1)
UP43-110 (2)
UP53-45 (3)
UP53-46 (4)

Technical data

Flow range: 13 - 97 GPM
Head range: 18 - 35 Feet
Motor Hp: 1/2^(1,3), 3/4^(2,4) HP
Voltage: 1 x 115/230V
Fluid temperature range: 32°F (0°C) to 230°F (110°C)
Max. working pressure: 175 PSI
Flange to flange length:

8.5-inch (1,2)
10-inch (3,4)

Pump housing:

Cast iron (1,2)
Silicon bronze (3,4)

Connection types:

1.5-inch, 2-bolt (GF40/43) (1,2)
2", 2.5", 3" Non-ANSI (4 bolt) (3,4)

Performance curves

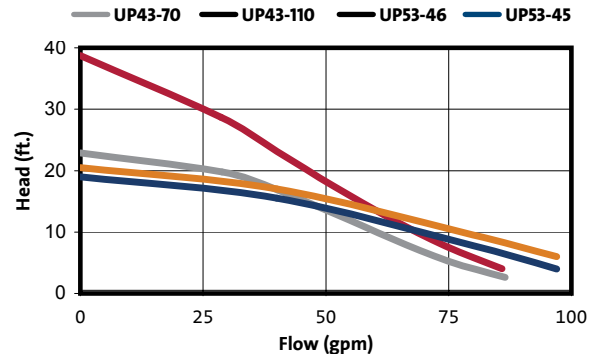

Large UPS – 3-speed circulator



Technical data

Flow range:	9 - 245 GPM
Head range:	1 - 59 Feet
Motor Hp:	1/3 to 3 Hp
Voltage:	1 x 115/230V 3 x 208-230V, 460V, 575V 460V, 575V
2-speed models	32°F (0°C) to 248°F (120°C)
Fluid temperature range:	175 PSI
Max. working pressure:	Cast iron, Silicon bronze
Pump housing:	Oval flange 1-1/4 inch Oval flange 1-1/2 inch
Connection type:	2", 2.5", 3" Non-ANSI 3" or 4" ANSI
Connection to VFD:	All 3-phase units are suitable
Optional features:	Relay or protection module

- Consult large UPS product guide for specific performance curves.
- You will notice a slight delay in valve reaction time; this helps to eliminate water hammer.

Performance curves

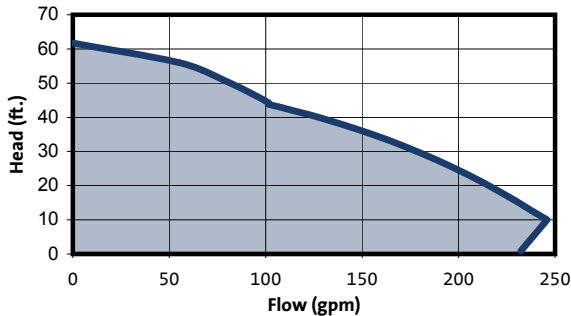

Dielectric isolation valves



Technical data

Pump Connection	Pipe Connection	Material Numbers		
		NPT (inch)	Solder (inch)	
GF 15/26	Bronze	1/2	96806129	
		3/4	96806130	
		1	96806131	
		1-1/4	96806132	
		1-1/2	96806133	
			1/2	96806134
			3/4	96806135
			1	96806136
			1-1/4	96806137
			1-1/2	96806138

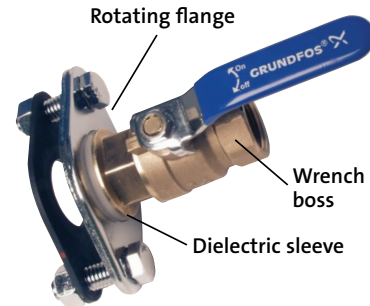

- Full port shut-off ball valve
- Dielectric isolation = no galvanic (dissimilar metal) corrosion
- Service pump without draining system
- Swivel flange allows optimum pump mounting position
- All hardware included

Zone valves



Valve body

Material: body: forged brass (optional low-lead brass*)
 seat:machined brass
 stem:stainless steel
 two o-ring seals and paddle:peroxide-cured EPDM

Flow: 1.0, 2.5, 3.5, 5.0, 7.5 Cv

Suitable fluids: water and glycol, low pressure steam

Maximum percent of glycol: 50%

Temperature range: 32 to 240° F (0 to 115° C)

Max. static pressure: 15 psi (1 bar) steam

300 psi (20 bar)

200 psi (13 bar) max. for press models

Max. close-off D pressure: 20 to 75 psid (138 to 517 kPa)

Close-off seat leakage: 100% bubble-tight

Connection: sweat: 1/2", 3/4" 1" & 1-1/4"

press: 1/2", 3/4" & 1"

NPT female: 1/2", 3/4" & 1"

SAE flare: 1/2"

inverted flare: 1/2", 3/4" & 1" sweat, fittings separate

Lay length (press connections): size 1/2 inch: 3-1/2"

size 3/4 inch: 3-5/8"

size 3/4 inch (PL)*: 5"

size 1 inch: 4-1/8"

Actuator

Material: base and cover: polycarbonate

base plate:aluminum

Motor: AC voltage: 24 V - 120 V, 50/60 Hz

Power requirements: 5.0 W, 7 VA

Power connections: Terminal screws with auxiliary switch: 24 V only

Wire lead length:18" (45 cm), 24 V only

6" (15 cm), 120 V

Humidity: 95% non-condensing

Full Stroke Time: On: <60 seconds

Off: 6 seconds

*Complies with NSF/ANSI/CAN 372

Zone controls

Pump zone controls – ZSR Z-one™ Relay

Single and multi-zone pump controls

Control up to 6 circulator pumps

Compatible with low voltage thermostats

- Power supply: 120 VAC, 50/60 Hz
- Transformer voltage: 24 VAC
- Max. transformer load: 6 VA (ZSR101), 40 VA (ZSR103-106)
- Electrical switch rating: 10A (ZSR101), 20A (ZSR103-106) max combined
- Ambient temperature range: 32 – 115 °F



CALEFFI

Code	Description	Lbs
ZSR101	Single zone relay	1.0
ZSR103	3 zone pump control	2.0
ZSR104	4 zone pump control	2.0
ZSR106	6 zone pump control	2.0

Valve zone controls – ZVR Z-one™ Relay

Multi-zone valve relay board

Control up to 6 zone valves

Compatible with low voltage thermostats

Automatic resettable low voltage fuse

- Power supply: 120 VAC, 50/60 Hz
- Transformer voltage: 24 VAC
- Max. transformer load: 40 VA (ZVR103/4)
- 80 VA (ZVR106)
- Electrical switch rating: 20A max combined
- Ambient temperature range: 32 – 115 °F



CALEFFI

Code	Description	Lbs
ZVR103	3 zone valve control	2.0
ZVR104	4 zone valve control	2.0
ZVR106	6 zone valve control	2.0
NA10343	Expansion transformer	0.1

GRUNDFOS GO APP – Feature Highlights

With Grundfos GO, you can control pumps and monitor duty points, power consumption, settings, and temperature via Bluetooth technology. Grundfos GO is always online, always updated, and always ready to use – wherever and whenever you need it.



**Grundfos GO
New Pump Tool**

Guided Setup

After the pump is connected to Grundfos GO, we recommend that you follow the guided setup in Grundfos GO. The guided setup helps you to select the optimal settings for the current system. By choosing the optimal settings, you can lower the energy consumption and prevent potential noise problems. If you select Use default settings, the pump uses the factory setting, constant curve (zone pump), AUTOADAPT.

Dashboard

The dashboard provides a full overview of pump's operation and settings.

From this screen the installer can:

- Start or stop the pump.
- Change the control mode or setpoints.
- Review alarms and trend data.
- Access advanced settings such as panel lock, venting conditions, and firmware updates.

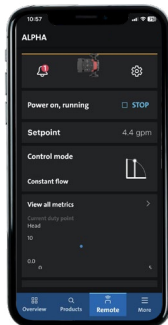

Flow Calculator

The Grundfos Go Flow Calculator offers the installer the ability to input specific heat load requirements for each zone. The calculator will calculate the most efficient flow rate based on friction loss, delta T, and btuh algorithms loaded into the software. Using the flow calculator ensures maximum comfort and energy savings.

Commissioning Report

Once the pump has been commissioned, the installer can create a detailed, electronic commission report that can be saved for future reference and shared with other stakeholders directly from the app.

The report contains:

- Detailed pump information (Model, Serial Number, Product Code)
- Date of installation
- Performance Data
- System Settings
- Alarms and Warnings
- Historical Data

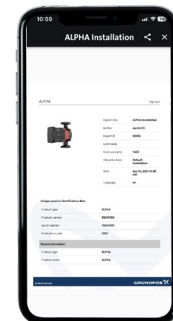

Trend Data

In the Trend data menu in Grundfos GO, you can see system data for the last 10 or 100 on-cycles.

You can see the following data:

- Duration of each on-cycle
- Flow
- Head
- Estimated media temperature.

You can use the trend data for system optimization and fault finding.

Firmware Updates

Once connected to Grundfos GO, the app automatically checks if the product has the latest firmware installed. If a newer version is available, a red dot in Settings menu will appear in Grundfos GO with the text Firmware update available.

Follow the guide in Grundfos GO to install the firmware update.

Download today from Apple or Google stores.



Eliminating air – purging, bleeding, & quiet comfort

Water contains dissolved gasses. Cold water contains more dissolved gasses than hot water. When filling a hydronic system for the first time, proper procedures must be followed to manage air elimination.

The most important requirement is to purge all free air from the hydronic system. Elimination of free air ensures quiet operation, protects system components and, provides proper transfer of heat-energy.

By raising the system pressure during purging, air bubbles trapped in upper floor loops are re-absorbed and carried down to the purge location. The sudden discharge of water through the purge valve creates rapid flow that forces trapped air within the system to be expelled.

- Zoning with circulators, utilizing isolation valves, and a purge fitting, will allow for fast elimination of air in primary, secondary, and tertiary piping
- Radiant loops are easily purged if you use valved manifolds to purge one loop at a time
- Standing cast iron radiators will have individual vents for purging air prior to starting the system

Once free air is eliminated and the first heating cycles begin, dissolved gases will come out of the solution and create problems – unless you've planned for eliminating air on an ongoing basis. The best location for air elimination devices is immediately after the heat source: that's where the majority of air will be forced out of the solution.

- Devices, such as air scoops or micro-bubble scrubbers are very effective at removing dissolved air – if installed correctly!
- Gravity float-vents are typically located where air collects and will automatically allow gases to pass out of the hydronic system
- Unchecked air trapped in hydronic systems can accelerate corrosion, damage components, create system noise, and lead to no-heat calls

18 inches minimum or 18 pipe diameters of straight pipe before air-scoop

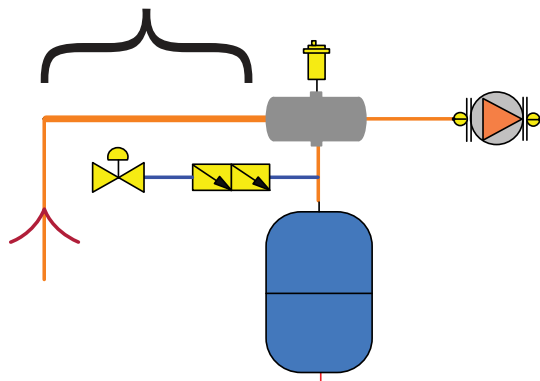

Straight pipe distance can be less than 18 inches

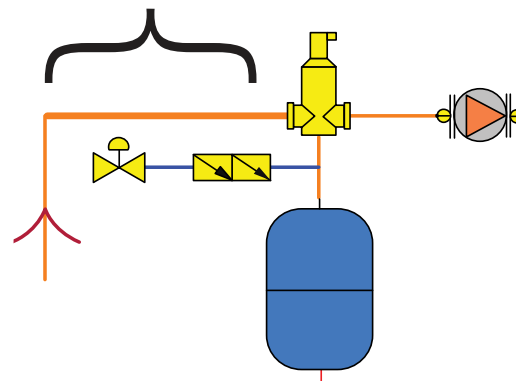

Pump installation

- Always point the cable entry downwards to prevent water from entering the terminal box.
- Wet-rotor pumps must always be mounted with the shaft in a horizontal position.
- Before starting the pump, flush clean water through the system to remove all foreign material.
- Never start the pump before the system is filled with water and properly vented. Even short periods of dry-running can damage the pump.
- The pump inlet should be placed as close as possible to the expansion tank (pumping away).
- Make sure it will be possible to vent the pump and the pipe system when making the installation. Follow proper piping procedures when installing venting components.
- Never install a larger pump than necessary; pump noise in the system can result.
- Do not install a circulator pump with aquastat too close to water heaters or storage tanks. Heat transfer may affect the aquastat operation.
- Vent pump if equipped with vent plug.



Recommended

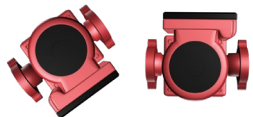

Optional

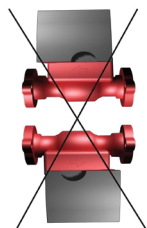

DO NOT
Mount Motor Shaft
in Vertical Position

Thermal expansion tank sizing

Water expands when it's heated. The level of expansion (in volume) is tied directly to system volume in gallons, the starting and ending temperatures or ΔT , static pressure, and expansion tank volume. If you adjust the air pressure in the thermal expansion tank so that it matches the system static pressure, the calculations are easy to master. We'll use Boyle's Law, which states that $P_1 \times V_1 = P_2 \times V_2$ (P = pressure and V = volume). $P_1 \times V_1 = \text{Constant Value}$. $P_2 \times V_2$ must equal the Constant Value.

Total system volume is 50 gallons

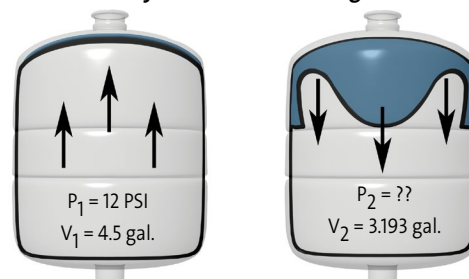

Water is heated from 70° F to 180° F

Determine final system pressure – example calculation:

Step 1: Determine the Constant Value

- $V_1 = 4.5$ gal.
- $P_1 = 12$ PSI
- $4.5 \times 12 = 54$ Constant Value

Step 2: Calculate thermal expansion for V_2

- System volume = 50 gal.
- Determine ΔT (finish 180°F – start 70°F) = 110°F
- Expansion multiplier = .02614 (expansion table for water)
- 50 gal. x .02614 = 1.307 gal. of thermal expansion
- $V_2 = 4.5 (V_1) - 1.307 = 3.193$ gal.

Step 3: Determine P_2 for final system pressure

- $P_2 \times V_2$ must equal 54
- $54 \div 3.193 (V_2) = 16.91$ PSI
- $16.91 \times 3.193 = 54$

Determining system volume

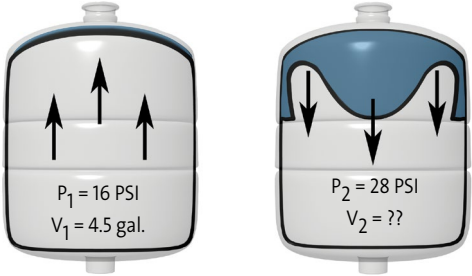

Water is heated from 70° F to 180° F

You find the pressure in a hydronic system is higher than you'd like. Let's say it rises to 28 PSI, which is too close to the relief valve's 30-lb limit. You'd like the final pressure to be less than 20 lbs, but you're not sure which size thermal expansion tank will be the best fit. (This same formula can be used for potable water thermal expansion by substituting pressure and relief values).

System fluid volume calculation example:

Step 1: Identify total system volume

- 16 PSI x 4.5 gal. = 72 (constant value)
- 72 ÷ 28 PSI = 2.57 gal. (V₂) tank volume
- 4.5 gal - 2.57 gal. = 1.93-gallons of thermal expansion
- Determine ΔT (finish 180° F - start 70° F) = 110°
- Expansion multiplier = .02614 (from thermal expansion table)

Total System Volume 1.93 gal. ÷ .02614 = 73.73 gal.

Let's move up to a 10-gallon thermal expansion tank, pumped up to 16 PSI.

- 16 PSI x 10 gal. = 160, our new constant value
- V₂ = 10 gal. – 1.93 gal = 8.07 gal.
- P₂ x 8.07 gal. = 160
- 160 ÷ 8.07 gal. = **19.83 PSI, which is exactly what you wanted**

Sizing water heaters – tank and tankless

Step 1: Determine percentage of hot water in flow

$$\frac{(\text{Desired bathing temperature} - \text{cold water temperature}^*)}{(\text{Hot water temperature} - \text{cold water temperature}^*)} =$$

$$(110^\circ \text{ F} - 40^\circ \text{ F}) \div (140^\circ \text{ F} - 40^\circ \text{ F}) = .7 (70\%)$$

* Must be coldest inlet temperature seen during the year

Step 2: Hot water required

- Measure GPM flow rate of desired bathing temperature (Use bucket and time fill rate)
- Example: 3 GPM x .7 = 2.1 GPM of hot water
- 2.1 GPM x 30 minutes = 63 gal. of hot water required

Step 3: Energy required per gallon of hot water

- A gallon of water weighs 8.33 lbs. and it takes 1 BTU to raise 1 lb. of water 1° F.
- ΔT = 100° F x 8.33 lbs./gal. = 833 BTU/gal. required net input

Step 4: Determine water heater size requirements

Tankless:

- 2.1 GPM x 833 BTU/gal. = 1,749.3 BTU/min. or 104,958 net BTU/hr. input
- Net input = gross input x operating efficiency
- The net input must meet or exceed 104,958 BTU/hr. in this case

Storage tank:

- Assume 50 gallons/40,000 BTU gross input @ 82% operating efficiency 40,000 BTU x .82 = 32,800 BTU net input.
- 32,800 BTU ÷ 833 BTU/gal. = 39.4 GPH recovery rate
- 39.4 GPH ÷ 60 minutes = .657 GPM
- 30-minute run-time = 19.7 gal. recovery
- Turbulent mixing of cold with hot water in the tank will reduce the available storage from 50 gallons to about 44 gallons
- Add 19.7 gal. to 44 gal. and you'll have a net available hot water draw of 63.7 gallons for a 30-minute draw

Calculating heat losses

Energy moves from hot to cold – always. The ΔT determines how quickly that happens. Any materials in-between the ΔT will slow the rate of energy transfer. A few easy steps will help you build a heat loss survey – the rock-solid foundation from which you can build castles of comfort that will exceed customer expectations.

You need to measure each room’s surface area that is exposed to colder air. The net square footage (subtract windows and doors) is then multiplied by a factor that represents the BTU energy loss per square foot. For example, if you want to maintain 70°F in 0°F temperature, use the column under “70.” Insert that number in the “factor” box and multiply your net square footage to obtain the BTU heat loss. Add up all of the BTU heat losses in that column to obtain the total for that room. You can use this room-by-room heat loss calculation to choose heat emitters and/or determine why an existing room over- or under-heats. There are many computer programs that quickly and accurately determine heat loss and gain, and are accepted by code authorities for permit applications.

Heat loss example:

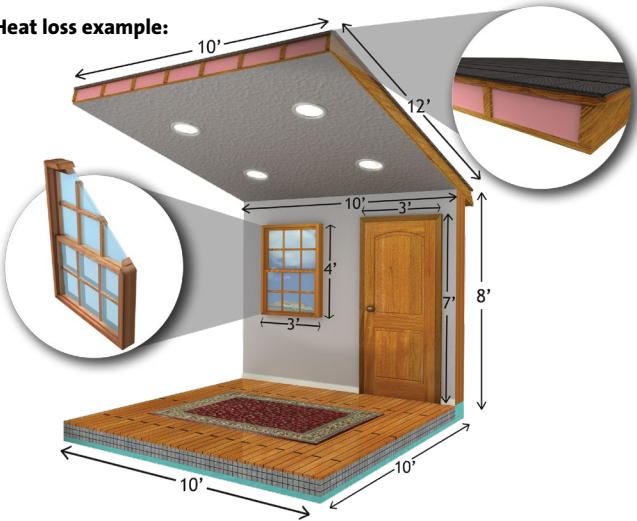

Design ΔT for location	80	70	60	50	40
Window - single pane	138	121	104	86	69
Window - double pane	92	81	69	58	46
Frame wall no insulation	32	21	17	15	12
Frame wall R-11	7	5.8	4.8	4.6	3.5
Frame wall R-19	3.7	3.2	2.8	2.3	1.8
Ceiling no insulation	55	48	41	35	28
Ceiling R-11	7.5	7	5.8	4.5	3.5
Ceiling R-19	4.6	4.4	3.5	2.3	2.1
Ceiling R-30	3	2.5	2.2	1.8	1.3
Ceiling R-38	2.1	1.8	1.6	1.3	1.1
Floor R-11	6.6	5.8	4.9	4.1	3.2
Floor R-19	4.1	3.7	3.1	2.6	2
Door - wood solid core	37	32	28	23	18
Door - insulated core	38	33	28	24	19
Door - glass single pane	92	81	69	58	46
Door - glass double pane	58	51	44	36	29

Slab heat loss per linear foot exposed

Slab - No edge insulation	64.8	56.7	48.6	40.5	32.4
Slab - 2-inch edge insulation	16.8	14.7	12.6	10.5	8.4

Square foot x factor = BTU loss

Item	Sq. ft.	Factor	BTUs
Window	12	81	972
Door	21	32	672
Net wall	47	3.2	150.4
Ceiling	120	1.8	216
Floor			
Slab: exp. feet	100	14.7	1,470
Total BTUs for room			3,480.4

5

5

76

77

Outdoor reset

Heat loss is directly affected by outdoor air temperatures: the colder the outdoor temperature, the greater the heat loss. Non-modulating boilers run until the thermostat is satisfied; the burner is turned on and off by the aquastat. This wastes energy by overheating the water during most of the heating season. Outdoor sensor monitors the outdoor air temperature and may also include sensors to monitor return water temperature to prevent sustained flue gas condensation within the boiler and/or cold-shocking cast iron boilers. More advanced outdoor reset controls monitor outdoor, supply, and return water temperatures – even the amount of fuel that should be burned.

To use the outdoor reset control properly, you need to know four things:

1. Maximum supply-water temperature (MT)
2. Lowest supply-water temperature (LT)
3. Indoor supply-water ΔT (= MT – LT)
4. Outdoor temperature ΔT (= 68°F – coldest air temperature)

The reset ratio = $(MT - 68) \div (68 - \text{coldest outdoor air temperature})$

Example: 180°F MT; 68°F LT; Designed for 10°F outdoor air
 Reset ratio = $(180 - 68) \div (68 - 10) = 112 \div 58 = 1.9$
 For every 1°F drop in outdoor air temperature, the supply-water temperature will be increased 1.9°F (starting at 68°F).

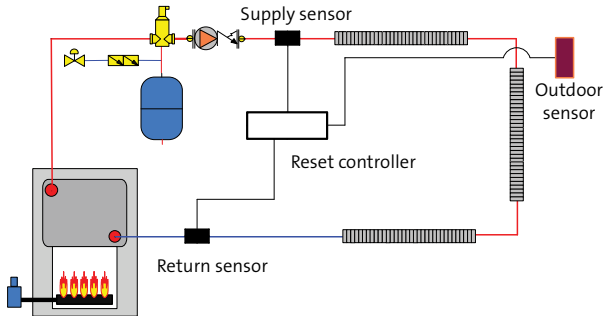

Pipe sizing

The flow rate required is determined by how many BTUs must be transported and the ΔT of the supply/return. If we use a 20° F ΔT , the transfer rate will be 10,000 BTUs per each GPM of flow. Water weighs 8.34 lbs. per gallon and it takes one BTU to raise 1 lb. of water 1° F. 8.34×60 (minutes for 1 GPM) $\times 20$ (ΔT) = 10,008 BTUs. Rounding down to 10,000 makes it easy to calculate flow rates. If the heat source has a net output of 100,000 BTUs, the flow rate needs to be 10 GPM at 20° ΔT .

You can quickly match tubing sizes to required BTU loads. The maximum fluid velocity should be **no more than 4 feet per second** to avoid velocity noise and or erosion corrosion . The following charts show GPM flow rates for each pipe size.

This chart is for copper tubing. If you need 15,000 BTUs delivered, then 1/2" copper (nominal pipe size) would be a perfect match.

Pipe Size	1/2"	3/4"	1"	1 1/4"	1 1/2"	2"	2 1/2"	3"
Max. GPM	3.2	6.5	10.9	16.3	22.9	39.6	75	120

The following flow chart is for PEX tubing.

Pipe Size	3/8"	1/2"	5/8"	3/4"	1"
Max. GPM	1.2	2	4	6	9.5

Water hammer

Water hammer (or hydraulic shock) is the sudden increase in pressure inside a pipe caused by a sudden change of velocity or direction of fluid in the pipe. When this occurs, a pressure wave travels back through the piping network until it finds a point of relief. If not addressed properly, water hammer can result in damaged pipes, ruptured fittings, and appliances.

Conditions causing water hammer:

- 1) Hydraulic shock – quick reacting valves, rapid startup/shut down of pumps, entrained air, restrictions in flow caused by kinks or corrosion in pipes, automatic valves on sprinkler systems, faulty float controls in toilet cisterns, long piping runs
- 2) Thermal shock – vapor (steam) collapsing with water rushing in to take its place
- 3) Differential shock – vapor (steam) and condensate flow at the same time but at different velocities

Possible solutions to water hammer problems:

- Reduce system pressure - install a pressure-reducing valve on main supply line
- Shorter branched piping Lengths
- Lower fluid velocities > 5.0ft/sec.
- Install inline surge arrestor(s)
- Slow closing valves
- Increase valve size
- Install air vent

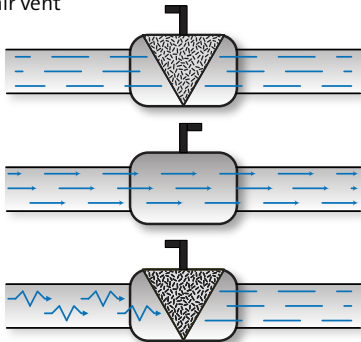

Pipe noise transmission

Noise transmission is when sound, such as banging, is transferred into the wall of a water pipe. It is common in iron and copper pipes (compared to plastic) as metal amplifies the noise.

Some causes of noise transmission:

- Water rushing through the pipe – high velocity, turbulent flow
- Restricted flow in pipes caused by undersized plumbing
- Valves or taps that are not fully open
- Any object hitting or rubbing on an exposed pipe
- Worn or slit tap washer pads
- Loose fitting pipes that can vibrate
- Air in pipes
- Expanding piping
- Pump cavitation
- Pump dry-run condition
- Noise being transmitted from a neighbor's service pipes to your pipes due to high-density living e.g. flats or units
- Impact sprinklers commonly used in parks and playing fields
- Check valve broken
- Sediment buildup in hot water tank



Corrosion of pipes

There are countless reasons for the corrosion of metallic (copper, galvanized, brass, cast iron, etc.) pipes and fittings. Corrosion is often the result of poor water quality or environments surrounding the piping networks.

Types of Corrosion

Galvanic or dissimilar metal:

Two or more different metals in direct contact with each other. One becomes the corroding sacrificial anode and the other becomes the acquiring cathode.

Pitting:

Type 1 - Predominately cold hard to moderately hard water pH between 7 and 7.8, levels of dissolved carbon dioxide, high alkalinity, pitting is deep and narrow

Type 2 - Hot soft water pH below 7.2, fluid temperatures above 140°F, pitting is narrower than Type 1.

Type 3 - Cold soft water pH above 8, wide and shallow pitting, blue water and/or pipe blockage.

Flux-induced pitting:

Older fluxes were acid-based and very aggressive to cold-water piping networks. Present as green-colored scale buildup in narrow bands parallel to tubing or around the periphery of flux residues.

Erosion:

Fluid velocities above 4ft./sec. and/or turbulent flow creating bright shiny smooth U-shaped grooves or gullies free of scale buildup. Several factors contribute; Poor piping workmanship - ends under reamed, not fully inserted into fittings, not cut square, dented or crimped, globules of solder; Poor design - too many elbows, undersized valves/fittings; Abrasive particulate matter present in fluid.

Microbiological:

Stagnation of fluid creates a biological film on internal piping surfaces; odors may be present.

Corrosion of pipes (continued)

Stress corrosion cracking:

Install dielectric or insulating coupling/fittings usually associated with brass, stainless steel and, high-strength steels. Pipe cracks where localized corrosion has combined with steady tensile stresses and where high levels of chlorides, hydrogen, and ammonia are present.

Dezincification of brass:

Dissolution of zinc, leaving a porous and low-strength structure behind.

Corrosive water:

High or low pH levels resulting in black, red or bluish-green stains and/or metallic taste. High levels of dissolved oxygen and/or salts, sulfates, or iron bacteria maybe present.

Electrolysis:

Corrosion or scale present on the outside of piping rather than inside.

Corrosive Water	Scale Forming Water
Low pH	High pH
Soft or non-carbonate hardness	Hard high levels of carbonate
Low alkalinity	High alkalinity



Corrosion of pipes - possible solutions

Galvanic or dissimilar metal:

Install dielectric or insulating couple or fittings

Pitting:

Type 1 - Use recognized ASTM approved material

Type 2 - Reduce system temperature to less than 140°F, pH below 8.5

Type 3 - Water treatment

In general, the following could apply to all three types of pitting: reduce fluid velocity – with different speed or size of pump; reduce turbulent flow - remove elbows, longer pipe runs: review water chemistry: Is the water conditioner calibrated properly?

Flux induced pitting:

Today's fluxes are not susceptible (ASTM approved); limit flux application to specific surface and avoid excessive use.

Erosion:

Limit fluid velocities to 4 ft./sec., smaller or reduce speed of circulator, larger diameter piping; proper workmanship; good plumbing design/practices; modification to water chemistry (treatment); use larger valves or fittings; install air/particulate separators.

Microbiological:

Use or maintaining chlorinated water, increase water temperature; eliminate stagnation situations through periodic pump exercise.

Stress corrosion cracking:

Select the proper material for the environment. Decrease piping load pressures (add supports); coat or isolate the piping surface; check water softener chemistry.

Dezincification of brass:

Avoid yellow brass components.

Corrosive water:

Install neutralizing filters, check water conditioner chemistry, lower water temperatures between 120°F and 130°F, and use filtration for suspended solids.

Electrolysis:

Remove unnecessary electrical appliances or wiring connected to piping, make sure piping network is properly grounded, and avoid galvanized piping.

Scale build-up

Scale build-up most often appears in hard water environments, but can also occur in soft water environments. Naturally occurring chemical compounds, typically carbonates of calcium and magnesium accumulate on surfaces, like pipes, pumps, fixtures, and appliances. Reducing the life expectancies of components and increasing your energy costs.

Causes of scale build-up

- Minerals (ions) like calcium and magnesium in supersaturated conditions
- The type of surface – rough or smooth
- Fluid temperature
- Fluid velocity
- System pressure
- pH levels
- Water source – mixing surface and groundwater's
- Turbulent flow area – pump volutes, piping elbows, and valves

Reduce or eliminate scale build-up options

- Chemical treatment – water treatment systems
- Reverse osmosis

Modifying piping configurations are not always possible; you are really left with two possible options. **1)** Lower the fluid temperature by 5 to 10 degrees; this reduces the chance of minerals coming out of the solution forming scale. **2)** Lower the system pressure; again impacts ions in the solution and lowers pressures in turbulent areas where most of the scale can occur.



Circulators	Noise	Squealing	Check for air / Install air eliminator	
			3-piece circulator / Oil bearing assembly	
			Air scoop not installed correctly, requires 18-IN pipe diameters of straight piping before entering air scoop	
			Is air scoop installed properly?	
			Purge system	
			Check system temperature / Limit function	
			Install wet rotor circulator	
			Power head mounted in wrong position	
			Rattling / Banging / Grinding	Replace circulator coupler
				Misaligned motor mount / Replace motor
	Worn bearing assembly or impeller – Replace if needed			
	Replace circulator with wet rotor model			
	Leaking	From flanges	Replace flange gasket or flanges if needed	
			Bearing assembly	Replace bearing assembly or circulator
Copper adapter			Replace or repair fitting	
Flange thread			Replace adaptor, nipple, or flange	

Circulators	Performance	No heat / Low heat	Insulate piping
			Insufficient NPSH
			Check for air / Install air eliminator
			Check power supply (Voltage)
			Check system pressure
			Check for good, clean neutral
			Is direction of flow correct?
			Check function of flow valve
			IFC Model - Remove, clean, and/or replace valve
			Check that all valves on zone are open
Too much heat	Check for proper sizing of circulator		
	Check proper speed if circulator is variable		
	Replace circulator if not functioning		
	Check operation of flow valve		
Baseboard Heating	Cast Iron	No heat / Low heat	IFC Model - Clean or replace check-valve
			Check limit control function / On/off contact / Replace if needed
			Bleed baseboard / Purge zone
			Check that valve is open
Overheating	Zone system	Check thermostat operation/ Replace if needed	Check for air flow disruption
			Increase system temperature
			Add more baseboard
			Re-pipe system using reverse-return method

Baseboard Heating

Fin-Tube

No heat / Low heat	Open louvers
	Remove carpeting to increase air flow
	Open / adjust old-style check-valve
	Move drapes or furniture away from baseboard
	Clean debris and pet hair from fins
	Add more baseboard
	Purge air from zone / Test for slab leak
	Increase system temperature
	Check circulator function / Replace if needed
	Check thermostat function / Replace if needed
Overheating	Close louvers
	Remove some of the fin
	Zone system
	Check thermostat operation / Replace if needed
	Decrease system temperature
	Install outdoor reset control
	Check flow-valve operation
Check for system or slab leak	

Valves

Boiler Relief	Leaking	Check system pressure
		Check PVR function
		Check if expansion tank is full - drain / Could be non-bladder tank
		Check expansion tank diaphragm / Change tank
T & P Valves	Leaking	Check expansion tank sizing
		Check relief-valve spring / Replace valve
		Check water pressure/ Install PRV
		Check cold water line for check-valve
Three Way	No heat	Thermal expansion / Install thermal expansion tank
		Check water temperature / Test aquastat
		Check location of circulator
		Check zone-valve function
Radiator Valve	No heat - One radiator	Check circulator function
		Check reverse aquastat function
		Check thermostat function
Thermostatic Radiator Valve	No heat - One radiator	Check for power, voltage
		Check to see if valve is open
		Check for valve obstruction
Thermostatic Radiator Valve	No heat - One radiator	Check operation of actuator
		Check for valve operation
		Check for valve obstruction

Water Heaters

6	Gas	No hot water	Check / Relight pilot	
			Test / Replace thermal couple	
			Vent spill switch tripped - reset / replace	
			Check aquastat / gas valve operation / Vapor safe limit	
		Not enough hot water	Check aquastat well, calcium build-up / Replace if needed	
			Survey hot water load / Install larger heater	
	Oil	No hot water	Raise temperature / Install mixing valve	
			Insulate piping	
			Not enough hot water	Check aquastat operation / Replace if needed
				Cracked electrode ceramic - Replace if needed
6	Oil	No hot water	Clean, tune up	
			Check oil primary control operation / Replace	
			Check oil supply, oil pump operation	
		Not enough hot water	Check aquastat well for calcium build-up / Replace if needed	
			Survey hot water load / Install larger heater	
			Raise temperature / Install mixing valve	

Water Heaters

6	Electric	No hot water	Check Upper / Lower aquastat function
			Check electrical supply, circuit breaker
			Test element operation / Replace if needed
	Not enough hot water	Survey hot water load / Install larger heater	
		Raise temperature / Install ASSE 1016/1017 mixing valve	
		Insulate piping	

Radiators

6	Panel Recessed Freestanding Convectors	No heat / Low heat	Bleed air
			Check that valve is open
			Check radiator / system piping
			No air, then look at flow problem
			Check circulator operation / sizing
			Check radiator sizing
			Disassemble, check radiator valve for broken stem
	Increase system temperature		
	Over heating	Zone system	
		Install thermostatic radiator valve	
		Check thermostat operation / Replace if needed	
		Re-pipe system using reverse-return method	
		Decrease system temperature	

Noises	Expansion	System	Check ΔT / Slow down flow of system
			Check sizing of expansion tank
		Baseboard radiation	Align friction glides on brackets
			Pipe penetrations at walls must be oversized
			Long runs must have expansion compensators
	Element must have play and not be too rigid		
	Radiant	Pex tubing	Oversize penetration openings in walls and floors
			Staples or J-hooks too tight
			Allow for tubing to expand
		Extruded aluminum plates	Must not touch each other / Space properly
			End loops must be large / mushroom heads
		Air in tubing	Injection pumping minimizes noise and expansion
			Proper air eliminator to remove micro bubbles
			Purge into bucket to see micro bubbles
		Radiant manifolds	Raise system fill pressure when purging
			Flow meters always on supply manifolds
Valves or actuators always on return manifolds			
Circulator too large			
		Check by-pass valves	



















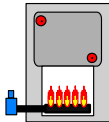

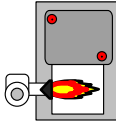



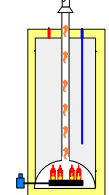

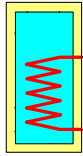



Piping	Performance	Low heat	Internal scale build-up
			Insulate piping
			Check for correct sizing for BTU output
			Check for flow restrictions
			Check that system piping is correct
	Leaking	Erosion / Noise	Is fluid velocity too high?
			Is flow restricted at inlet of circulator?
			Is system fluid dirty or full of debris?
		Corrosion	Are there any dissimilar metals connected?
			Is PH of the system fluid too high or low?
			Is the electrical system grounded correctly?
			Is there a bad ground wire on water main?
		Expansion and contraction	Is pipe supported correctly?
			Are pipe hangers too tight?
Does piping rub against any wood?			
Solder joints	Is there room for the copper to expand?		
	Clean joint thoroughly and re-solder		
		Replace copper pipe and fitting and re-solder	

Air	Air in System or Noise	No heat - Air bound	Install air eliminator
			Air scoops need 18-IN pipe dia. of straight pipe before entering scoop
			Check autovent / Replace if needed
			Bleed radiators or purge zones
			Remove air scoop, install micro bubble design
			Check system fill pressure
			Check relief valve

Outdoor Reset Control	No heat	Test outdoor sensor
		Test supply/mix sensor
		Test reset control function
		Check reset control perimeters
		Sensor placed next to heated ventilation
		Sensor placed in direct sun light, place on north facing wall
		Check boiler command

ALPHA Trend Data <small>Connect with Grundfos GO App</small>	Head on an increasing trend and lower flow	Blockage might be developing
	On-cycles increasing in duration	Increasing difficulty in meeting demand of supply heat
	Continuously short on-cycles	Heat supply is too high for demand
	Sudden drop in media temperature	Check boiler supply temperature

Drawing symbols

	Hot water piping		Horizontal tube radiator
	Cold water piping		Radiant panel circuit
	Hose bib / boiler drain		Radiant panel circuit w/zone valves
	Hose bib / boiler drain		Condensing boiler
	Globe valve		Gas fired boiler
	Pressure reducing valve		Oil fired boiler
	Pressure relief valve		Solar collector array
	3-way motorized mixing valve		Gas fired water heater
	3-way thermostatic valve		Indirect DHW tank
	Zone valve 2-way		
	Diverter tee		
	P/S fitting		
	Backflow preventer		
	Strainer		
	Float type air vent		
	Air separator		
	Cast iron air scoop		
	Circulator w/isolation flanges		
	Circulator w/integral flow check		
	Diaphragm-type expansion tank		
	Heat exchanger		
	Fin tube baseboard		
	Cast iron radiator		

Permanent magnet motors

Permanent magnet motor or electronically commutated motor (ECM) is a high-efficiency programmable brushless DC motor utilizing a permanent magnet rotor, built-in inverter, and microprocessor. ECM motors are inherently more efficient than shade-pole or permanent-split-capacitor (PSC) motor designs. Utilizing a unique microprocessor based motor controller, efficiencies can now be maintained across the entire operating range, saving considerable electrical energy compared to conventional motor technologies.

The microprocessor is the brain of this motor, converting AC power to DC power to operate the internal electronics, and controlling the ability to adjust the power frequency (which controls the speed or RPM) and the amount of current (power) delivered to the motor.

Magnets are encased in the rotor housing, eliminating the need for slip rings, brushes, and energizing of the rotor. This translates into less friction - no rubbing parts, lower operating temperatures, and energy savings.

- High output power-to-mass ratio
- Improved comfort levels
- Programmable (allow for system optimization)
- Reduced noise
- More starting torque per watt
- Longer life span
- Built-in self-protection features
- Maintenance free

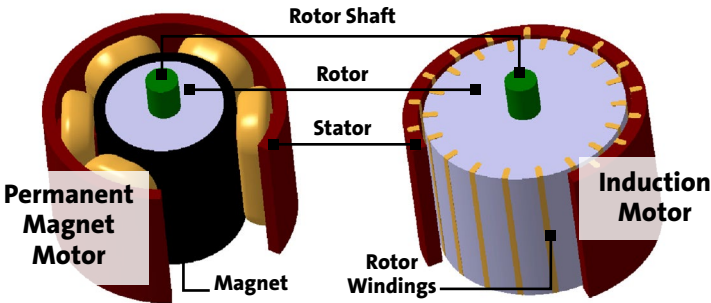

Abbreviations used in heating			
British thermal unit	BTU	Gallons per minute	GPM
British thermal unit per hour	BTUh	Gallons per hour	GPH
Cubic centimeter	cc	Ounce	oz
Cubic foot	cu ft	Pound	lb
Cubic feet per min.	cfm	Pounds per square inch	psi
Cubic feet per sec.	cfs	Pounds per square inch, gauge	psig
Cubic inches	cu in	Pounds per square IN, absolute	psia
Degree	deg or °	Revolutions per min.	rpm
Degree, Celsius	°C	Revolutions per sec.	rps
Degree, Fahrenheit	°F	Second	sec
Diameter	diam	Specific gravity	sp gr
Direct-current	d - c	Specific heat	sp ht
Feet per min.	fpm	Square foot	sq ft
Feet per sec.	fps	Square inch	sq in
Foot	ft	Volt	V
Foot-pound	ft-lb	Watt	W
Freezing point	fp	Watt hour	Whr
		Watt min.	Wmin

Equivalent value in different units		
1 hp	=	746 W
		0.746 kW
		33,000 ft-lb per minute
		550 ft-lb per second
1 hp	=	33.475 BTU _h
		34.5 lbs of steam/hr from and at 212°F
1 kW	=	1,000 W
		1.34 hp
		3.53 lbs water evaporated per hour from and at 212°F
1 W	=	0.00134 hp
		0.0035 lb of water evaporated per hour
1 kWh	=	1,000 Whr
		1.34 hp/hr
		3,600,000 joules
		3.53 lbs water evaporated from and at 212°F
		22.75 lbs of water raised from 62°F to 212°F
1 Joule	=	1 watt second
		0.000000278 kWhr
MJ (Megajoule)	=	1,000,000 Joule = 948 BTU
		239 kcal

Equivalents of electrical units		
1 kW	=	1.34 hp
		0.955 BTUs
		57.3 BTU _m
		3438 BTU _h
1 hp	=	746 W
		42.746 BTU _m
		2564.76 BTU _h
1 BTU	=	17.452 W _{min}
		0.2909 Whr

Conversion factors				
Water				
U.S. Gallons	X	8.34	=	Pounds
U.S. Gallons	X	0.13368	=	Cubic Feet
U.S. Gallons	X	231	=	Cubic Inches
U.S. Gallons	X	3.78	=	Liters
Imperial Gallons	X	277.3 Cubic Inches		
Imperial Gallons at 62°F	=	10.0 Pounds		
Cubic In. of Water (39.2°F)	X	0.03613	=	Pounds
Cubic In. of Water (39.2°F)	X	0.004329	=	U.S. Gallons
Cubic In. of Water (39.2°F)	X	0.576384	=	Ounces
Cubic Feet of Water (39.2°F)	X	62.427	=	Pounds
Cubic Feet of Water (39.2°F)	X	7.48	=	U.S. Gallons
Cubic Feet of Water (39.2°F)	X	0.028	=	Tons
Pounds of Water	X	27.72	=	Cubic Inches
Pounds of Water	X	0.01602	=	Cubic Feet
Pounds of Water	X	0.12	=	U.S. Gallons

Pressure		
1 Pound Per Square Inch	=	144 pounds per square foot
		2.0355 inches of mercury at 32°F
		2.0416 inches of mercury at 62°F
		2.31 feet of water at 62°F
		27.71 inches of water at 62°F
1 Ounce Per Square Inch	=	6.895 kilopascal
		0.1276 inches of mercury at 62°F
1 Atmosphere (14.7 Lbs. Per Sq. In.)	=	1.732 inches of water at 62°F
		2116.3 pounds per square foot
		33.947 feet of water at 62°F
		30 inches of mercury at 62°F
		29.922 inches of mercury at 32°F
		760 millimeters of mercury at 32°F
		101.3 kilopascal
1 Inch Water (at 62°F)	=	235.1 ounces per square inch
		0.03609 pounds per square inch
		0.5774 ounce per square inch
		5.196 pounds per square foot
		0.248 kilopascal
1 Foot Water (at 62°F)	=	235.1 ounces per square inch
		0.433 pounds per square inch
		62.355 pounds per square foot
1 Inch Mercury (at 62°F)	=	0.491 pounds per square inch
		7.86 ounces per square inch
		1.132 feet water at 62°F
		13.58 inches water at 62°F

Converting PSI to Head (ft.)

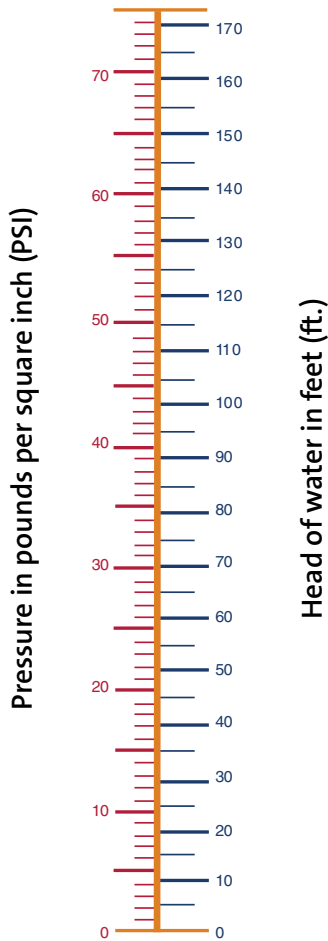

Pounds to kilograms

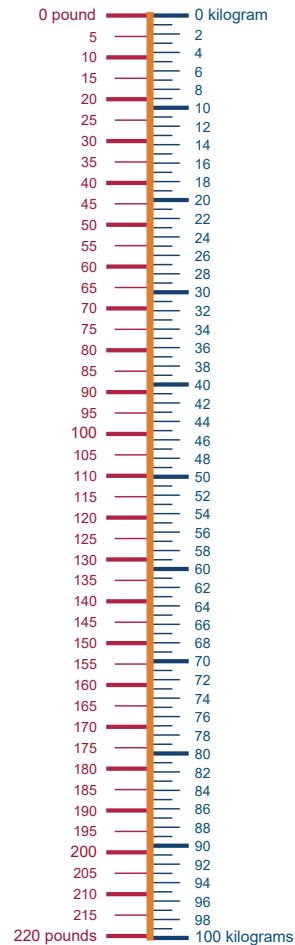

Gallons to liters

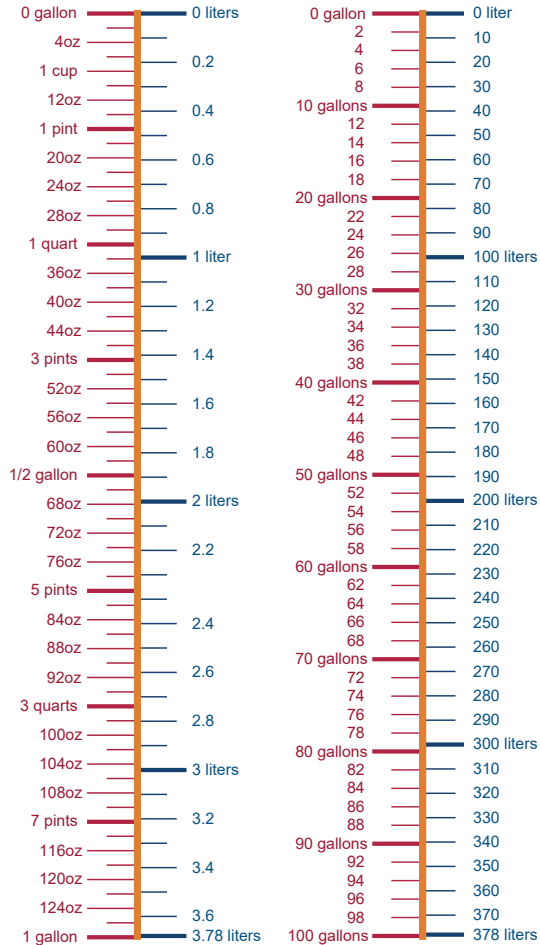

Inches to centimeters

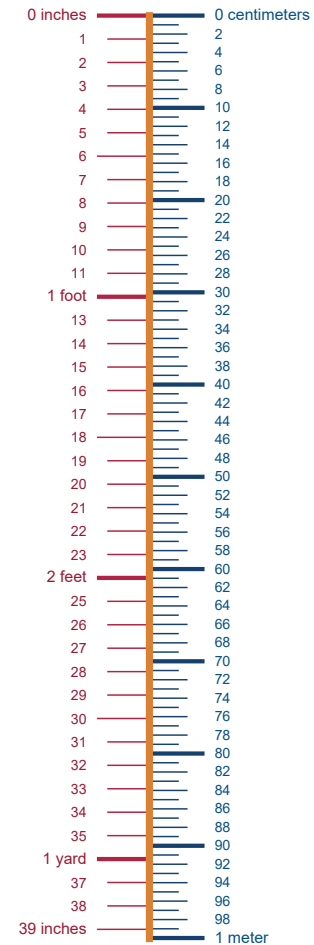

Yards to meters

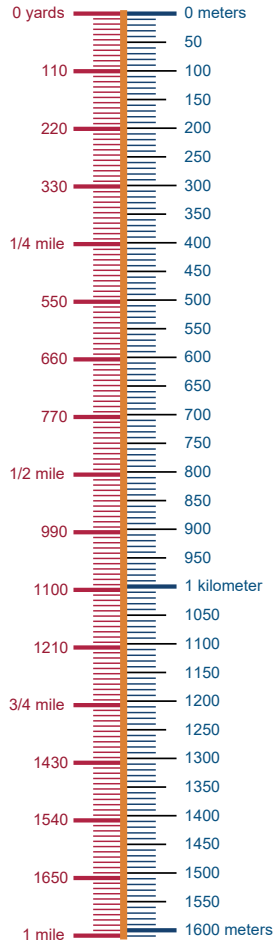

Fahrenheit to centigrade

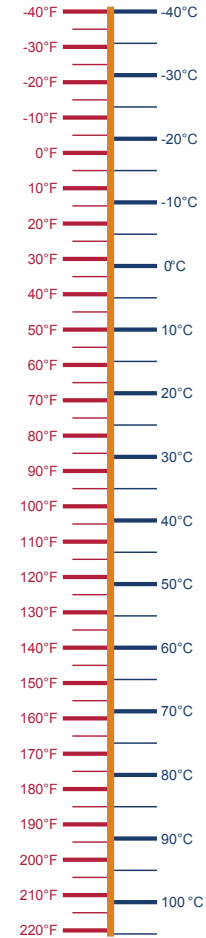

Feet Head of water to PSI

Feet Head	Pounds per square inch	Feet Head	Pounds per square inch
1	0.43	100	43.31
2	0.87	110	47.64
3	1.30	120	51.97
4	1.73	130	56.30
5	2.17	140	60.63
6	2.60	150	64.96
7	3.03	160	69.29
8	3.46	170	73.63
9	3.90	180	77.96
10	4.33	200	86.62
15	6.50	250	108.27
20	8.66	300	129.93
25	10.83	350	151.58
30	12.99	400	173.24
40	17.32	500	216.55
50	21.65	600	259.85
60	25.99	700	303.16
70	30.32	800	346.47
80	34.65	900	389.78
90	38.98	1000	433.00

NOTE: One foot of water at 60°F equals .433 pounds pressure per square inch.

To find the pressure per square inch for any feet head not given in this table above, multiply the feet head by .433.

Water pressure to feet Head

Pounds per square inch	Feet Head	Pounds per square inch	Feet Head
1	2.31	100	230.90
2	4.62	110	253.98
3	6.93	120	277.07
4	9.24	130	300.16
5	11.54	140	323.25
6	13.85	150	346.34
7	16.16	160	369.43
8	18.47	170	392.52
9	20.78	180	415.61
10	23.09	200	461.78
15	34.63	250	577.24
20	46.18	300	692.69
25	57.72	350	808.13
30	69.27	400	922.58
40	92.36	500	1154.48
50	115.45	600	1385.39
60	138.54	700	1616.30
70	161.63	800	1847.20
80	184.72	900	2078.10
90	207.81	1000	2309.00

NOTE: One pound of pressure per square inch of water equals 2.31 feet of water at 60°F.

Therefore, to find the feet head of water for any pressure not given in this table above, multiply the pressure (pounds per square inch) by 2.31.

Capacity of round storage tanks										
Depth or length (ft.)	Number of gallons									
	Inside diameter (inches)									
	18	24	30	36	42	48	54	60	66	72
1	1.1	1.96	3.06	4.41	5.99	7.83	9.91	12.24	14.81	17.62
2	26	47	73	105	144	188	238	294	356	423
2-1/2	33	59	91	131	180	235	298	367	445	530
3	40	71	100	158	216	282	357	440	534	635
3-1/2	46	83	129	184	252	329	416	513	623	740
4	53	95	147	210	288	376	475	586	712	846
4-1/2	59	107	165	238	324	423	534	660	800	952
5	66	119	181	264	360	470	596	734	899	1057
5-1/2	73	130	201	290	396	517	655	808	978	1163
6	79	141	219	315	432	564	714	880	1066	1268
6-1/2	88	155	236	340	468	611	770	954	1156	1374
7	92	165	255	368	504	658	832	1028	1244	1480
7-1/2	99	179	278	396	540	705	889	1101	1335	1586
8	106	190	291	423	576	752	949	1175	1424	1691
9	119	212	330	476	648	846	1071	1322	1599	1903
10	132	236	366	529	720	940	1189	1463	1780	2114
12	157	282	440	634	864	1128	1428	1762	2133	2537
14	185	329	514	740	1008	1316	1666	2056	2490	2960

Capacity of rectangular tanks in U.S. gallons:

- Measure tank (inches): length, width, height
- Then multiply length x width x height ÷ 231

Example:

- 60" length x 36" width x 48" height = 103,680 cu. in.
- 103,680 ÷ 231 = 448.8 gallons

Pipe Size (in.)	Number of smaller pipes equivalent to one larger pipe PIPE SIZE (IN INCHES)											
	1/2	3/4	1	1-1/4	1-1/2	2	2-1/2	3	3-1/2	4	5	6
1/2	1.00	2.27	4.88	10.00	15.80	31.70	52.90	96.90	140	205	377	620
3/4		1.00	2.05	4.30	6.97	14.00	23.30	42.50	65	90	166	273
1			1.00	2.25	3.45	6.82	11.40	20.90	30	44	81	133
1-1/4				1.00	1.50	3.10	5.25	9.10	12	19	37	68
1-1/2					1.00	2.00	3.34	6.13	9	13	23	39
2						1.00	1.67	3.06	4.50	6.50	11.90	19.60
2-1/2							1.00	1.82	2.70	3.87	7.12	11.70
3								1.00	1.50	2.12	3.89	6.39
3-1/2									1.00	1.25	2.50	4.25
4										1.00	1.84	3.02
5											1.00	1.65
6												1.00

Copper tubing - water capacity (Gal.) / linear foot

Type K										
Pipe size (in.)	3/8	1/2	5/8	3/4	1	1-1/4	1-1/2	2	2-1/2	3
Gallon per foot	0.006	0.011	0.017	0.023	0.040	0.063	0.089	0.156	0.242	0.345
Type L										
Gallon per foot	0.007	0.012	0.017	0.025	0.043	0.065	0.092	0.161	0.248	0.354
Type M										
Gallon per foot	0.008	0.013	–	0.027	0.045	0.068	0.095	0.165	0.254	0.363

Steel & wrought iron pipe - water capacity per linear foot

Pipe Size (in.)	1/2	3/4	1	1-1/4	1-1/2	2	2-1/2	3	3-1/2	4	5	6
Gallon per Foot	0.016	0.023	0.040	0.063	0.102	0.170	0.275	0.390	0.530	0.690	1.100	1.500

PEX - approximate - water capacity (Gal.) / 100 foot*

Tubing Size (in.)	3/8	1/2	5/8	3/4	1
Gallon(s)	.50	.92	1.33	1.84	3.04

* Check manufacturer for specific capacities

Capacity of pipe in cubic feet of gas per hour (Based on 0.60 Specific Gravity, 0.30" W.C. Pressure Drop)		Length of pipe (Feet)														
		10	20	30	40	50	60	70	80	90	100	125	150	175	200	
Nominal iron pipe size (inches)	Internal diameter (inches)	3/4"	278	190	152	130	115	105	96	90	84	79	72	64	59	55
		1"	520	350	285	245	215	195	180	170	160	150	130	120	110	100
1-1/4"	1.38	1050	730	590	500	440	400	370	350	320	305	275	250	225	210	
1-1/2"	1.61	1600	1100	890	760	670	610	560	530	490	460	410	380	350	320	

Linear expansion of pipe - inches per 100 feet					
Temp. degrees (F)	Cast iron	Brass or copper	Stainless steel	Carbon steel	Wrought iron
50	0.4	0.6	0.6	0.4	0.4
100	0.7	1.1	1.1	0.8	0.8
120	0.9	1.4	1.4	0.9	1.0
140	1.1	1.6	1.6	1.1	1.2
180	1.3	2.1	2.0	1.4	1.4
200	1.5	2.3	2.2	1.5	1.7
220	1.7	2.5	2.5	1.7	1.9
260	1.9	3.0	2.9	2.0	2.1
280	2.2	3.2	3.2	2.2	2.4
300	2.4	3.5	3.4	2.4	2.6
340	2.8	3.9	3.9	2.7	2.9

Heat losses from bare steel pipe based on 70°F surrounding air						
Diameter of pipe (inches)	Temperature of pipe, °F					
	100	120	150	180	210	240
	Heat loss per lineal foot of pipe - BTU per hour					
1/2	13	22	40	60	82	106
3/4	15	27	50	74	100	131
1	19	34	61	90	123	160
1-1/4	23	42	75	111	152	198
1-1/2	27	48	85	126	173	224
2	33	59	104	154	212	275
2-1/2	39	70	123	184	252	327
3	46	84	148	221	303	393
3-1/2	52	95	168	250	342	444
4	59	106	187	278	381	496
Heat losses from bare copper pipe based on 70°F surrounding air						
1/4	4	8	14	21	29	37
3/8	6	10	18	28	37	48
1/2	7	13	22	33	45	59
5/8	8	15	26	39	53	68
3/4	9	17	30	45	61	79
1	11	21	37	55	75	97
1-1/4	14	25	45	66	90	117
1-1/2	16	29	52	77	105	135
2	20	37	66	97	132	171
2-1/2	24	44	78	117	160	206
3	28	51	92	136	186	240
3-1/2	32	59	104	156	212	274
4	36	66	118	174	238	307

Heat losses from insulated pipe					
85 percent magnesia type					
BTU per linear foot per hour per °F					
Difference (surrounding air assumed 75°F)					
Pipe size (inches)	Insulation thickness (inches)	Max. temp. of pipe surface °F			
		125	175	225	275
1/2	1	0.145	0.150	0.157	0.160
3/4	1	0.165	0.172	0.177	0.180
1	1	0.190	0.195	0.200	0.203
	1-1/2	0.160	0.165	0.167	0.170
1-1/4	1	0.220	0.250	0.232	0.237
	1-1/2	0.182	0.870	0.193	0.197
1-1/2	1	0.240	0.247	0.255	0.260
	1-1/2	0.200	0.205	0.210	0.215
2	1	0.282	0.290	0.297	0.303
	1-1/2	0.230	0.235	0.240	0.243
	2	0.197	0.200	0.205	0.210
2-1/2	1	0.322	0.330	0.340	0.345
	1-1/2	0.260	0.265	0.270	0.275
	2	0.220	0.225	0.230	0.237
3	1	0.375	0.385	0.395	0.405
	1-1/2	0.300	0.305	0.312	0.320
	2	0.253	0.257	0.263	0.270
3-1/2	1	0.419	0.430	0.440	0.450
	1-1/2	0.332	0.340	0.345	0.352
	2	0.280	0.285	0.290	0.295
4	1	0.460	0.470	0.480	0.492
	1-1/2	0.362	0.370	0.379	0.385
	2	0.303	0.308	0.315	0.320

HEAT OUTPUT TABLE - 1 Temperature differential (°F)

	1°	2°	3°	4°	5°	6°	7°	8°	9°	10°
1.0	494	988	1,482	1,976	2,470	2,964	3,458	3,952	4,446	4,940
1.5	741	1,482	2,223	2,964	3,705	4,446	5,187	5,928	6,669	7,410
2.0	988	1,976	2,964	3,952	4,940	5,928	6,916	7,904	8,892	9,880
2.5	1,235	2,470	3,705	4,940	6,175	7,410	8,645	9,880	11,115	12,350
3.0	1,482	2,964	4,446	5,928	7,410	8,892	10,374	11,856	13,338	14,820
3.5	1,729	3,458	5,187	6,916	8,645	10,374	12,103	13,832	15,561	17,290
4.0	1,976	3,952	5,928	7,904	9,880	11,856	13,832	15,808	17,784	19,760
4.5	2,223	4,446	6,669	8,892	11,115	13,338	15,561	17,784	20,007	22,230
5.0	2,470	4,940	7,410	9,880	12,350	14,820	17,290	19,760	22,230	24,700
5.5	2,717	5,434	8,151	10,868	13,585	16,302	19,019	21,736	24,453	27,170
6.0	2,964	5,928	8,892	11,856	14,820	17,784	20,748	23,712	26,676	29,640
6.5	3,211	6,422	9,633	12,844	16,055	19,266	22,477	25,688	28,899	32,110
7.0	3,458	6,916	10,374	13,832	17,290	20,748	24,206	27,664	31,122	34,580
7.5	3,705	7,410	11,115	14,820	18,525	22,230	25,935	29,640	33,345	37,050
8.0	3,952	7,904	11,856	15,808	19,760	23,712	27,664	31,616	35,568	39,520
8.5	4,199	8,398	12,597	16,796	20,995	25,194	29,393	33,592	37,791	41,990
9.0	4,446	8,892	13,338	17,784	22,230	26,676	31,122	35,568	40,014	44,460
9.5	4,693	9,386	14,079	18,772	23,465	28,158	32,851	37,544	42,237	46,930
10.0	4,940	9,880	14,820	19,760	24,700	29,640	34,580	39,520	44,460	49,400

HEAT OUTPUT IN (BTUH)*

* 100% Water mean temperature of 120 °F

Flow Rate (GPM)

HEAT OUTPUT TABLE - 2 Temperature differential (°F)

	11°	12°	13°	14°	15°	16°	17°	18°	19°	20°
1.0	5,434	5,928	6,422	6,916	7,410	7,904	8,398	8,892	9,386	9,880
1.5	8,151	8,892	9,633	10,374	11,115	11,856	12,597	13,338	14,079	14,820
2.0	10,868	11,856	12,844	13,832	14,820	15,808	16,796	17,784	18,772	19,760
2.5	13,585	14,820	16,055	17,290	18,525	19,760	20,995	22,230	23,465	24,700
3.0	16,302	17,784	19,266	20,748	22,230	23,712	25,194	26,676	28,158	29,640
3.5	19,019	20,748	22,477	24,206	25,935	27,664	29,393	31,122	32,851	34,580
4.0	21,736	23,712	25,688	27,664	29,640	31,616	33,592	35,568	37,544	39,520
4.5	24,453	26,676	28,899	31,122	33,345	35,568	37,791	40,014	42,237	44,460
5.0	27,170	29,640	32,110	34,580	37,050	39,520	41,990	44,460	46,930	49,400
5.5	29,887	32,604	35,321	38,038	40,755	43,472	46,189	48,906	51,623	54,340
6.0	32,604	35,568	38,532	41,496	44,460	47,424	50,388	53,352	56,316	59,280
6.5	35,321	38,532	41,743	44,954	48,165	51,376	54,587	57,798	61,009	64,220
7.0	38,038	41,496	44,954	48,412	51,870	55,328	58,786	62,244	65,702	69,160
7.5	40,755	44,460	48,165	51,870	55,575	59,280	62,985	66,690	70,395	74,100
8.0	43,472	47,424	51,376	55,328	59,280	63,232	67,184	71,136	75,088	79,040
8.5	46,189	50,388	54,587	58,786	62,985	67,184	71,383	75,582	79,781	83,980
9.0	48,906	53,352	57,798	62,244	66,690	71,136	75,582	80,028	84,474	88,920
9.5	51,623	56,316	61,009	65,702	70,395	75,088	79,781	84,474	89,167	93,860
10.0	54,340	59,280	64,220	69,160	74,100	79,040	83,980	88,920	93,860	98,800

HEAT OUTPUT IN (BTUH)*

* 100% Water mean temperature of 120 °F

Flow Rate (GPM)

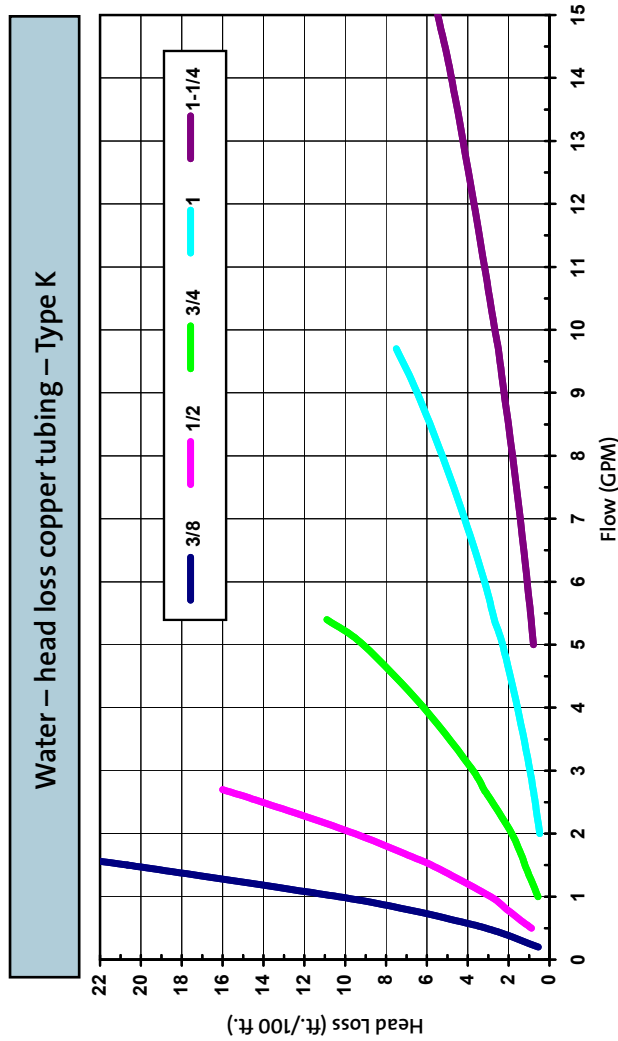
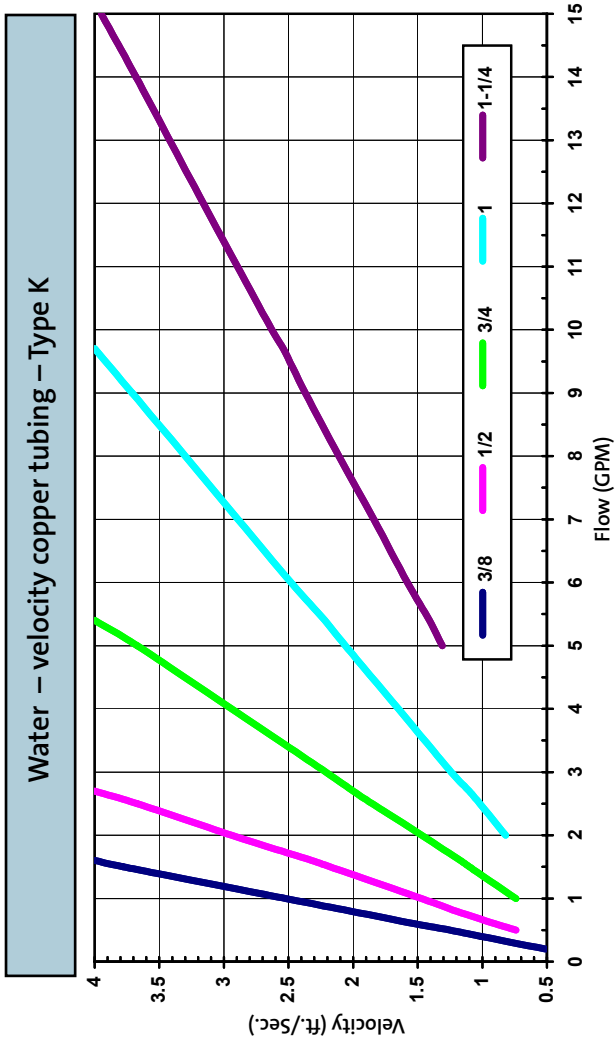

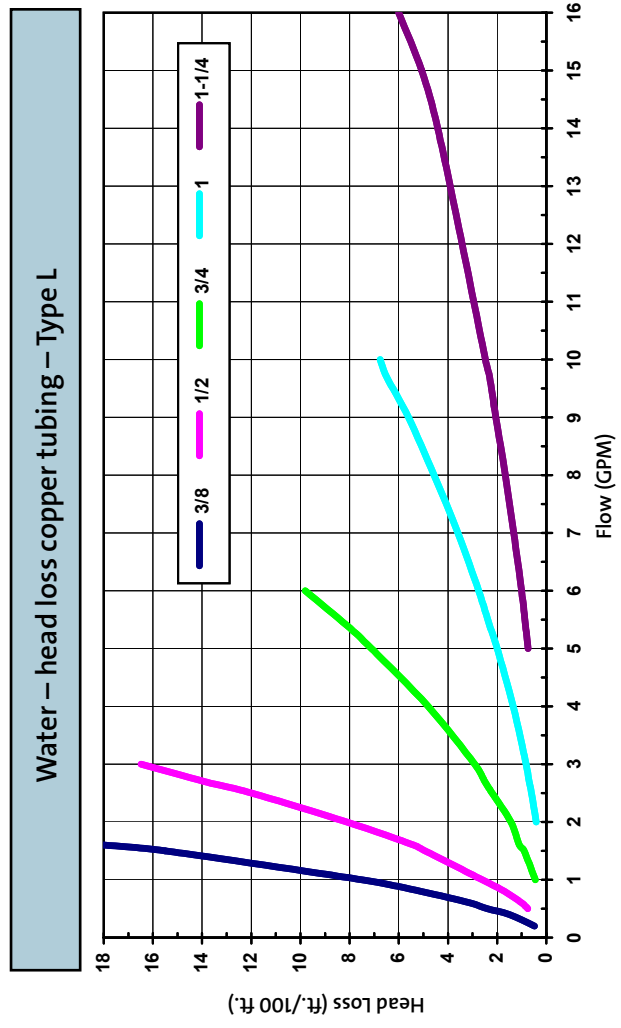
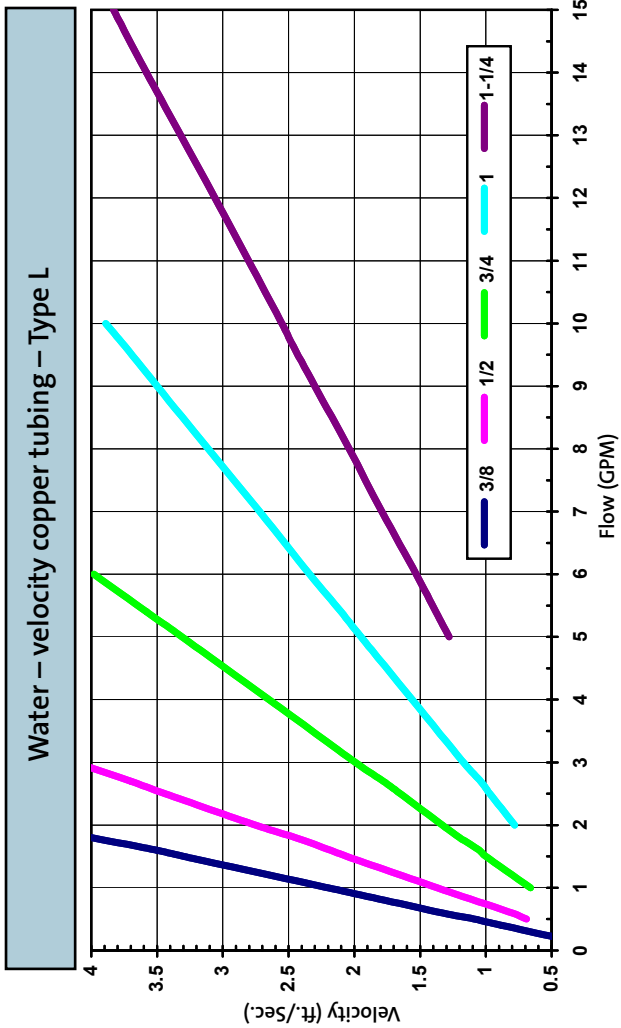

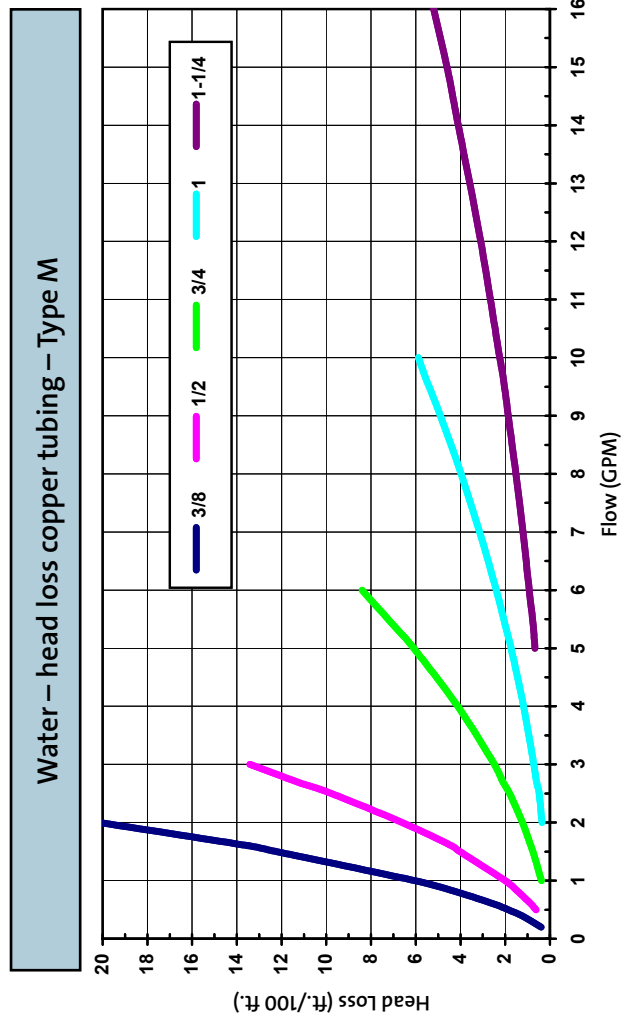
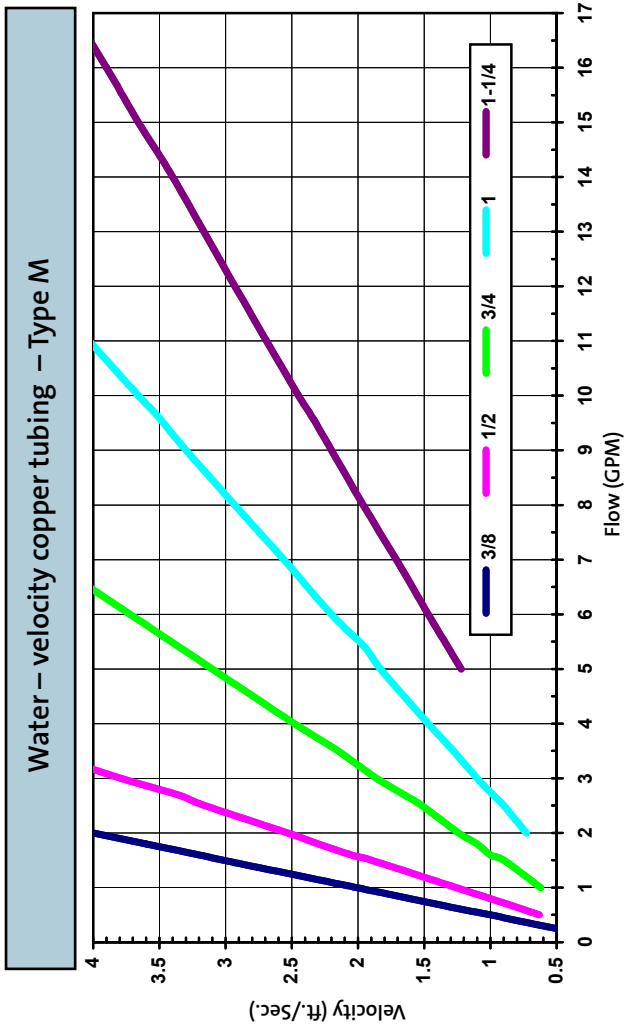

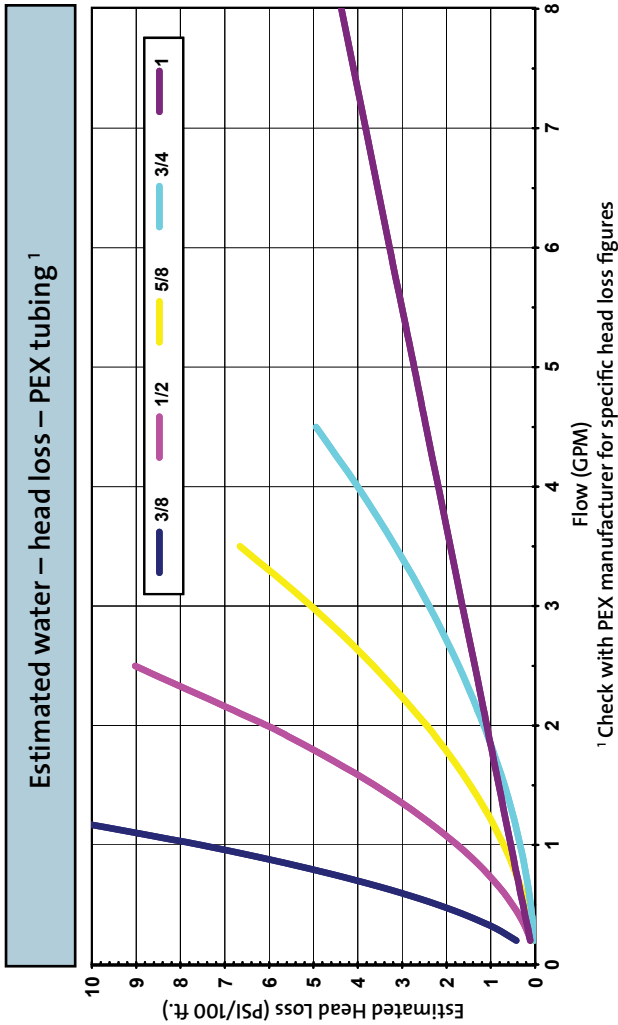
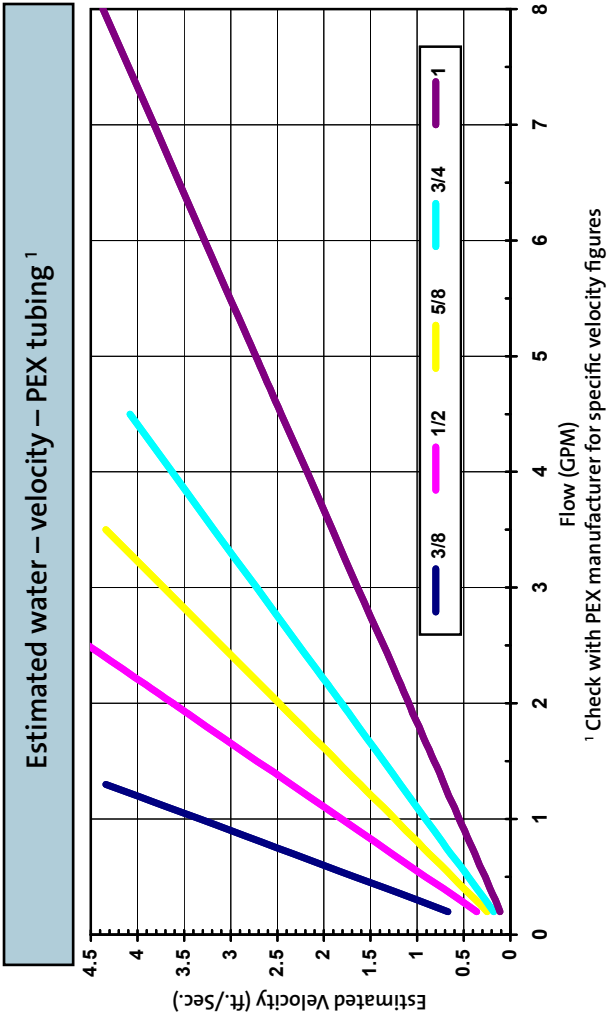

Maximum tubing flow rates and BTU/h loads (at 20°F ΔT)		
Pipe Size (Copper)*	Maximum Flow Rate (GPM)**	Heat Carrying Capacity (BTU/hr)
1/2"	3.2	32,000
3/4"	6.5	65,000
1"	10.9	109,000
1-1/4"	16.3	163,000
1-1/2"	22.9	229,000
2"	39.6	396,000

* Nominal pipe size

** Maximum 4 ft./sec.

BTU per hour glycol based:

$$\text{BTU/h (water @ 68°F)} = \text{GPM} \times 500 \times \Delta T \text{ (°F)}$$

$$\text{BTU/h (30% E. glycol @ 68°F)} = \text{GPM} \times 445 \times \Delta T \text{ (°F)}$$

$$\text{BTU/h (50% E. glycol @ 32°F)} = \text{GPM} \times 395 \times \Delta T \text{ (°F)}$$

$$\text{BTU/h (30% P. glycol @ 68°F)} = \text{GPM} \times 465 \times \Delta T \text{ (°F)}$$

$$\text{BTU/h (50% P. glycol @ 32°F)} = \text{GPM} \times 420 \times \Delta T \text{ (°F)}$$

Freezing point*

Concentration by volume	Ethylene glycol	Propylene glycol
55%	-50°F	-40°F
50%	-37°F	-28°F
40%	-14°F	-13°F
30%	+2°F	+4°F
20%	+15°F	+17°F

*Check with glycol manufacturer for specific volume concentration

Method to increase concentration of glycol in a hydronic system:

$$Vg = \frac{\text{TSV} (\text{PSd} - \text{PSt})}{(100 - \text{PSt})}$$

Vg = Quantity of glycol, in gallons, to be added

TSV = Total System volume in gallons

PSd = Percent of glycol solution desired

PSt = Percent of system solution by test (initial percent)

Example:

Total system volume (TSV) = 125 gal.

Initial percent of system solution from test (PSt) = 25%

Percent of glycol solution desired (PSd) = 45%

$$Vg = \frac{125(45-25)}{(100-25)}$$

Drain 33.3 gallons from the system and then refill the system with 33.3 gallons of glycol concentrate.

= 33.3 gallons of glycol concentrate required

General formulas:

Horsepower water	=	$\frac{\text{GPM} \times \text{head (ft.)} \times \text{specific gravity}}{3960}$
Horsepower brake	=	$\frac{\text{GPM} \times \text{head (ft.)} \times \text{specific gravity}}{3960 \times \text{pump efficiency}}$
Horsepower brake	=	$\frac{\text{GPM} \times \text{PSI} \times \text{specific gravity}}{1713 \times \text{pump efficiency}}$
Brake horsepower (motor)	=	$\frac{\text{Watts input} \times \text{motor efficiency}}{746}$
Efficiency (pump)	=	$\frac{\text{GPM} \times \text{head (ft.)} \times \text{specific gravity}}{3960 \times \text{pump BHP}}$
Head (ft.)	=	$\frac{\text{Pressure (PSI)} \times 2.31}{\text{Specific gravity}}$
Pressure (lbs./sq. in.)	=	$\frac{\text{Head (ft.)} \times \text{specific gravity}}{2.31}$
Pressure (PSI)	=	$\frac{\text{Head (ft.)} \times \text{Specific gravity}}{2.31}$
GPM	=	$\frac{\text{BTU/h}}{500 \times \Delta T (^{\circ}\text{F})}$
$\Delta T (^{\circ}\text{F})$	=	$\frac{\text{BTU/h}}{500 \times \text{GPM}}$
Head (ft.)	=	Pressure (PSI) x 2.31
Lbs. per square inch	=	Head in feet x .433

Water heating:

% Efficiency	=	$\frac{\text{GPH} \times 8.34 \times \text{temp. rise} \times 1.0 \text{ (specific heat)}}{\text{BTU/h. Input}}$
BTU/output	=	$\text{GPH} \times 8.34 \text{ lbs./gal.} \times \text{temp. rise} \times 1.0$
BTU/input	=	$\frac{\text{GPH} \times 8.34 \times \text{temp. rise} \times 1.0}{\% \text{ Efficiency}}$
GPH	=	$\frac{\text{BTU/h. input} \times \% \text{ efficiency}}{\text{Temp. rise} \times 8.34}$
Rise (DF)	=	$\frac{\text{BTU/h. input} \times \% \text{ efficiency}}{\text{GPH} \times 8.34}$
KW	=	$\frac{\text{GPH} \times 8.34 \times \text{temp. rise} \times 1.0}{3413}$

Determine % of hot water portion:

$$\frac{\text{MWT} - \text{C}}{\text{H} - \text{C}} = \frac{140 - 50}{180 - 50} = \frac{90}{130} = 69.2\% \text{ hot water}$$

Determine % of cold water portion:

$$\frac{\text{H} - \text{MWT}}{\text{H} - \text{C}} = \frac{180 - 140}{180 - 50} = \frac{40}{130} = 30.8\% \text{ cold water}$$

MWT = mixed water temperature ($^{\circ}\text{F}$)H = hot water temperature ($^{\circ}\text{F}$)C = cold water temperature ($^{\circ}\text{F}$)**Fluid velocity:**

Velocity (ft./sec.)	=	$\frac{.408 \times \text{GPM}}{(\text{pipe diameter in inches})^2}$
Velocity head (ft.)	=	$\frac{(\text{pipe velocity ft./sec.})^2}{64.4}$

Ohm's Law

VOLTS

$$\text{Volts} = \sqrt{\text{Watts} \times \text{Ohms}}$$

$$\text{Volts} = \frac{\text{Watts}}{\text{Amperes}}$$

$$\text{Volts} = \text{Amperes} \times \text{Ohms}$$

AMPERES

$$\text{Amperes} = \frac{\text{Volts}}{\text{Ohms}}$$

$$\text{Amperes} = \frac{\text{Watts}}{\text{Volts}}$$

$$\text{Amperes} = \sqrt{\frac{\text{Watts}}{\text{Ohms}}}$$

OHMS

$$\text{Ohms} = \frac{\text{Volts}}{\text{Amperes}}$$

$$\text{Ohms} = \frac{\text{Watts}}{\text{Amperes}^2}$$

$$\text{Ohms} = \frac{\text{Volts}^2}{\text{Watts}}$$

WATTS

$$\text{Watts} = \text{Volts} \times \text{Amperes}$$

$$\text{Watts} = \text{Amperes}^2 \times \text{Ohms}$$

$$\text{Watts} = \frac{\text{Volts}^2}{\text{Ohms}}$$

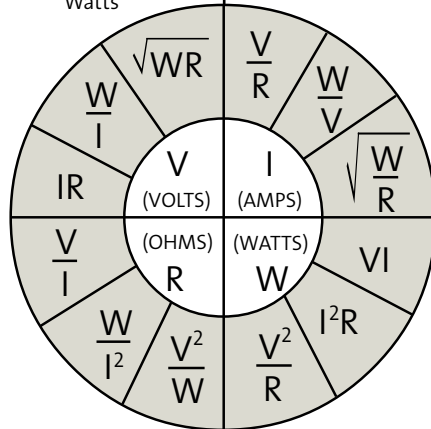

MOTOR EQUATIONS			
Value	Single Phase	Two Phase 4-Wire	Three Phase
I =	$(746 \cdot \text{Hp}) / (V \cdot \text{Eff} \cdot \text{Pf})$	$(746 \cdot \text{Hp}) / (V \cdot \text{Eff} \cdot \text{Pf} \cdot 2)$	$(746 \cdot \text{Hp}) / (1.73 \cdot V \cdot \text{Eff} \cdot \text{Pf})$
I =	$(1000 \cdot \text{KW}) / (V \cdot \text{Pf})$	$(1000 \cdot \text{KW}) / (V \cdot \text{Pf} \cdot 2)$	$(1000 \cdot \text{KW}) / (1.73 \cdot V \cdot \text{Pf})$
I =	$(1000 \cdot \text{KVA}) / V$	$(1000 \cdot \text{KVA}) / (V \cdot 2)$	$(1000 \cdot \text{KVA}) / (1.73 \cdot V)$
KW =	$(V \cdot I \cdot \text{Pf}) / 1000$	$(V \cdot I \cdot \text{Pf} \cdot 2) / 1000$	$(1.73 \cdot V \cdot I \cdot \text{Pf}) / 1000$
KVA =	$(V \cdot I) / 1000$	$(V \cdot I \cdot 2) / 1000$	$(1.73 \cdot V \cdot I) / 1000$
Hp =	$(V \cdot I \cdot \text{Eff} \cdot \text{Pf}) / 746$	$(V \cdot I \cdot \text{Eff} \cdot \text{Pf} \cdot 2) / 746$	$(1.73 \cdot V \cdot I \cdot \text{Eff} \cdot \text{Pf}) / 746$

Pf Motor power factor
Eff Motor efficiency
Hp Horsepower
I Amperes
V Voltage
KW Kilowatts
KVA Kilovolt-Ampere

Possibility in every drop

GRUNDFOS GO APP

With Grundfos GO, you can control pumps and monitor duty points, power consumption, settings, and temperature via Bluetooth technology. Grundfos GO is always online, always updated, and always ready to use – wherever and whenever you need it.



iOS

Download today from
Apple or Google stores.



Android

GRUNDFOS ECADEMY

GRUNDFOS ECADEMY is a free online training tool that helps you stay up-to-date with Grundfos pumps and services.

Visit grundfos.to/ecademy today and start your learning journey.



grundfos.to/learn

Scan to learn more
about our range of
residential solutions

Visit grundfos.us/pei to learn more about Department of Energy (DOE) pump energy index (PEI) requirements and PEI ratings on specific Grundfos models.

GRUNDFOS Americas
Brookshire, TX 77423

www.grundfos.us
www.grundfos.ca
www.grundfos.mx

The name Grundfos, the Grundfos logo, and be think innovate are registered trademarks owned by Grundfos Holding A/S or Grundfos A/S, Denmark. All rights reserved worldwide.

GRUNDFOS

LUPSL033 1125