

MGE model F

Service instructions



Original service instructions

CONTENTS

	Page
1. General information	3
1.1 Hazard statements	3
1.2 Notes	3
1.3 Scope of delivery	4
1.4 Safety details to be aware of when working on the product	4
2. Identification	5
2.1 Nameplates	5
2.2 Type key	6
2.3 Configuration	7
3. General description	7
3.1 Wiring diagrams and signal terminals	8
3.2 Control panel	9
3.3 Indicator lights	9
3.4 Setting using the R100 remote control	9
3.5 R100 menu structure	10
3.6 Alarms and warnings	11
3.7 Alarm overview	11
4. Fault finding	12
4.1 Safety instructions	12
4.2 Fault finding procedure	12
4.3 PC Tool E-products as service tool	13
4.4 Fault observations	14
4.5 Fault finding using the indicator lights on the control panel	14
4.6 Fault finding using alarm and warning codes	18
5. Maintenance	22
5.1 Lubrication of motor bearings	22
5.2 Replacement of motor bearings	23
6. Emergency operation (bypass)	25
6.1 Establishing emergency operation	26
6.2 Re-establishment of frequency converter operation	27
7. Drawings and diagrams	28
8. Tightening torques and lubrication	31
8.1 Tightening torques	31
8.2 Lubricating intervals and grease	31
9. Service tools	32



Read this document before starting service work on the product. Installation and service work must comply with local regulations and accepted codes of good practice.

Observe the safety instructions in the installation and operating instructions for the product.

1. General information

1.1 Hazard statements

The symbols and hazard statements below may appear in Grundfos installation and operating instructions, safety instructions and service instructions.



DANGER

Indicates a hazardous situation which, if not avoided, will result in death or serious personal injury.



WARNING

Indicates a hazardous situation which, if not avoided, could result in death or serious personal injury.



CAUTION

Indicates a hazardous situation which, if not avoided, could result in minor or moderate personal injury.

The hazard statements are structured in the following way:



SIGNAL WORD

Description of hazard

Consequence of ignoring the warning.
- Action to avoid the hazard.

1.2 Notes

The symbols and notes below may appear in Grundfos installation and operating instructions, safety instructions and service instructions.



Observe these instructions for explosion-proof products.



A blue or grey circle with a white graphical symbol indicates that an action must be taken.



A red or grey circle with a diagonal bar, possibly with a black graphical symbol, indicates that an action must not be taken or must be stopped.



If these instructions are not observed, it may result in malfunction or damage to the equipment.



Tips and advice that make the work easier.

1.3 Scope of delivery

These service instructions describe fault finding of pumps with Grundfos motors, type MGE model F (hereafter called MGE-F).

If the fault cannot be remedied by means of these instructions, or you require spare parts or technical assistance, contact your nearest Grundfos partner or company. See the back of these service instructions.

State the following information when you contact Grundfos to get help for fault finding:

- nameplate data of the pump the MGE-F is fitted to
- nameplate data of the MGE-F
- status of indicator lights on the control panel
- any alarm or warning and the corresponding fault code read with the Grundfos R100 remote control.

These service instructions are published and updated in the Grundfos GTI database.



These service instructions apply only for the MGE-F and its user interfaces (control panel, R100 and PC Tool E-products). If the application includes other Grundfos products or systems, refer to the service instructions of those products.

1.4 Safety details to be aware of when working on the product

WARNING

Electric shock

Death or serious personal injury

- Before starting any work on the product, make sure that the power supply is switched off and that it cannot be accidentally switched on.
- Wait 30 minutes before doing any work inside the product.
- Installation, commissioning, service, and maintenance of equipment, systems, and circuits may only be performed by Grundfos service technicians or a Grundfos Authorised Service Partner (ASP) who have attended training equivalent to Grundfos Electronics Service Expert (GESE) or similar.
- Always observe local applicable safety regulation.



WARNING

Electric shock

Death or serious personal injury

- Due to the capacitors of MGE-F, touching live electrical parts may be fatal, even after the mains supply has been disconnected. Disconnect the mains supply, and wait at least 30 minutes or the amount of time stated on the warning label under the terminal box cover before touching any live parts.
- Note that the relay may be connected to an external power supply and still be live after the mains supply to the motor has been disconnected.



2. Identification

2.1 Nameplates

The MGE-F nameplate (fig. 1) is fitted on the side of the terminal box (fig. 2).

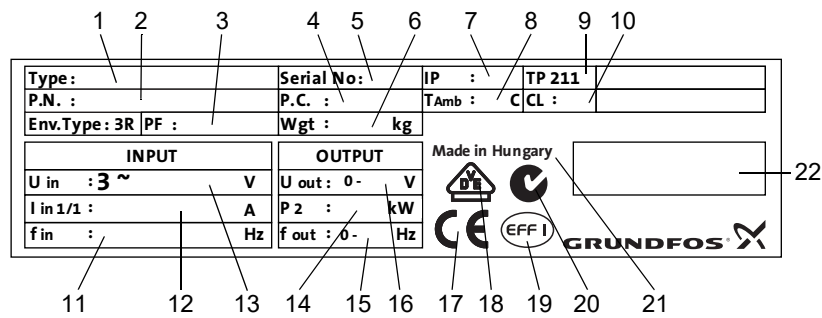
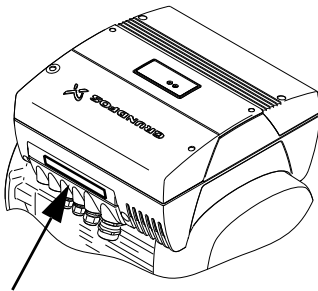

Fig. 1 Nameplate for MGE-F, efficiency 1 motor



TM04 2399 2508

Fig. 2 Position of nameplate

Pos.	Description	Pos.	Description
1	Type designation	12	Max. supply current at min. and max. supply voltage
2	Product number	13	Supply voltage
3	Power factor	14	Rated power
4	Production code, year/week	15	Output frequency
5	Serial number	16	Output voltage
6	Weight	17	CE mark
7	Enclosure class according to IEC 34-5	18	VDE mark
8	Maximum ambient temperature	19	Standard motor efficiency according to CEMEP
9	Motor protection according to IEC 34-11	20	C-Tick mark
10	Insulation class according to IEC 62114	21	Country of manufacture
11	Frequency	22	Bar code

The motor nameplates (fig. 3) are fitted under the terminal box (fig. 4).

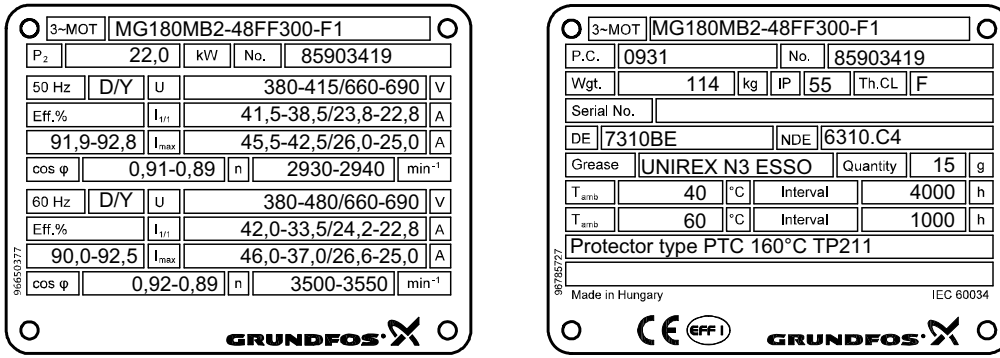

Fig. 3 Nameplates for standard motors with CE and UL approvals

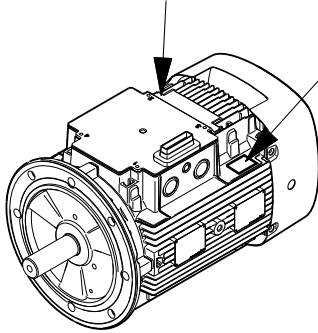

Fig. 4 Position of motor nameplates

TM04 2843 3208

TM04 3051 3508

2.2 Type key

Example	MG	E	160	M	D	2-	42	FF	300	-F	1
Motor Grundfos											
Electronically controlled											
Frame size according to IEC (centre line height of shaft of foot motor) [mm]											
160											
180											
Size of foot											
M											
L											
Length of stator core											
B											
D											
Number of poles											
2											
4											
Diameter of shaft end [mm]											
Flange version											
FF (free-hole flange)											
Pitch circle diameter, flange version [mm]											
Model designation for motor											
F											
Efficiency class for standard motor											
[] = not stated											
1 = EFF 1 motor											
2 = EFF 2 motor											

2.3 Configuration

The terminal box is configured from factory for the application and the pump type the motor is to be used for. The configuration file number appears from the terminal box configuration label which is placed inside the terminal box on the frame of the control panel. See figs 5 and 6.



Fig. 5 Configuration label

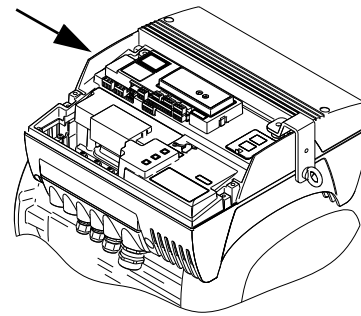

Fig. 6 Position of configuration label

If the terminal box is replaced or mounted on another motor, it must be reconfigured. Contact Grundfos Service.

TM04 2305 2308

TM04 2400 2508

3. General description

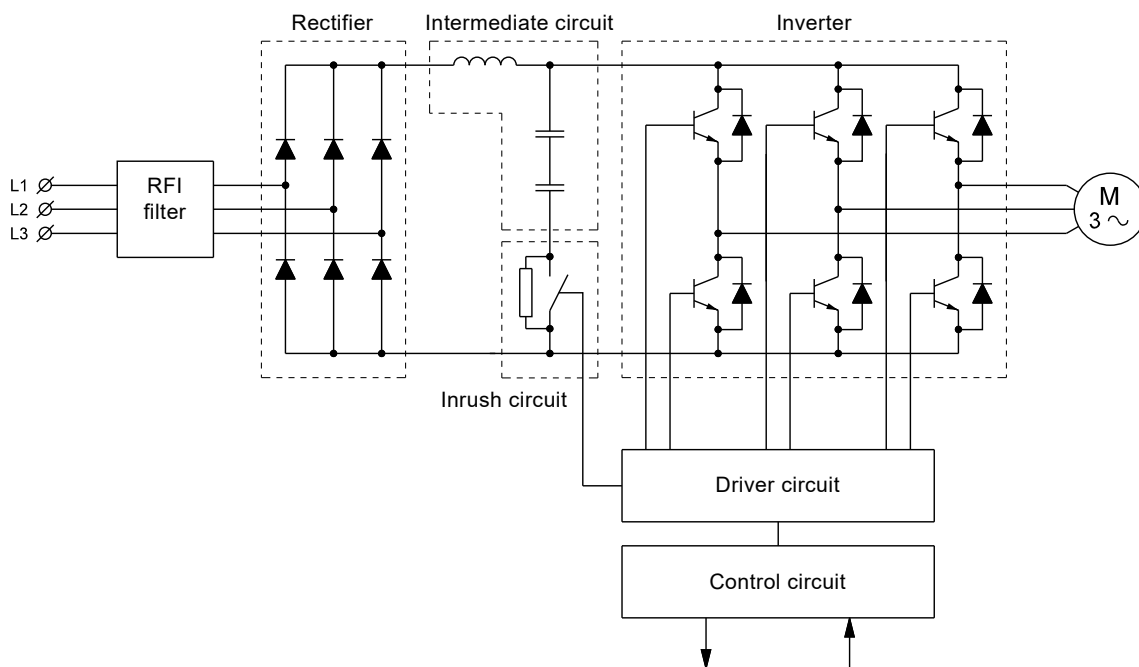

Fig. 7 Block diagram showing the functional blocks of the frequency converter

TM00 8679 4206

3.1 Wiring diagrams and signal terminals

The wiring diagram and the signal terminals depend on the pump application. Figures 8 to 11 are examples of the different functional modules available. Refer to the figure corresponding to the functional module fitted.

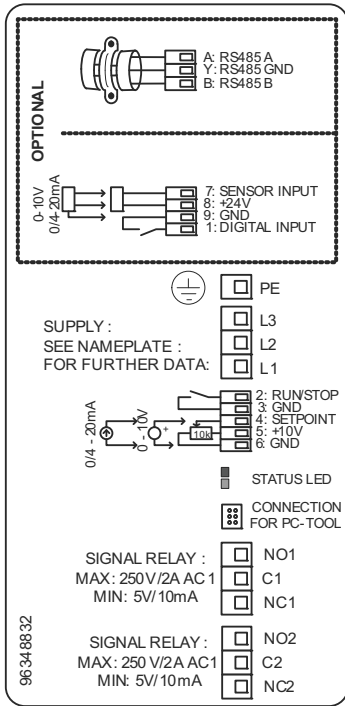

Fig. 8 I/O module and GENIbus

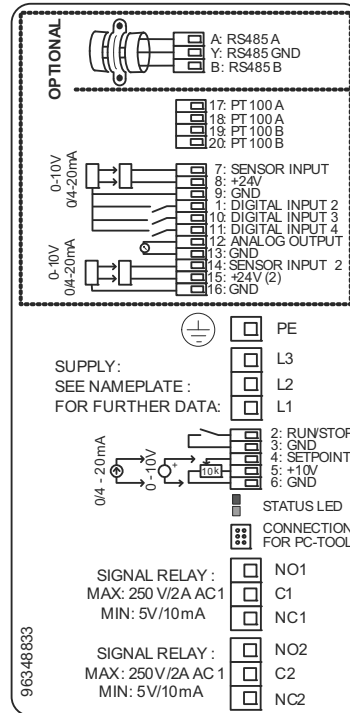

Fig. 9 Extended I/O module and GENIbus

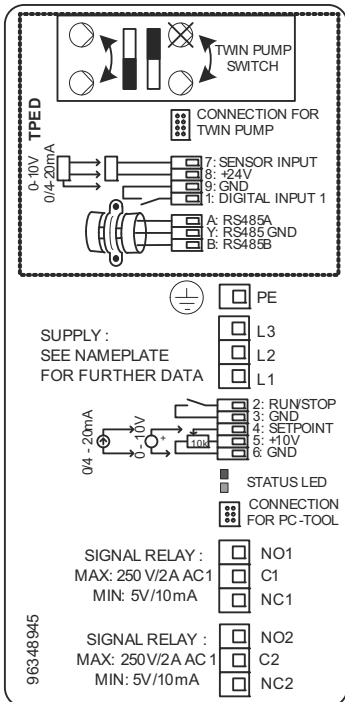

Fig. 10 TPED module

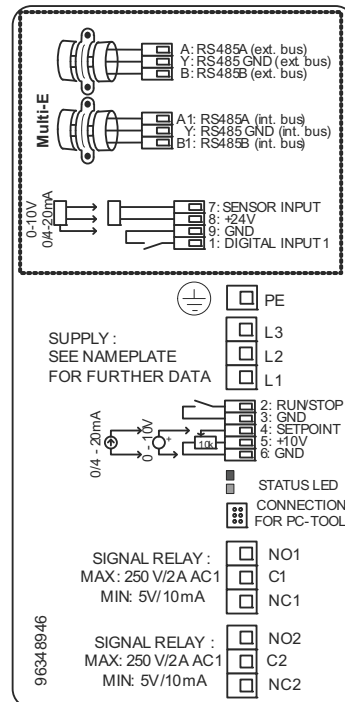

Fig. 11 Multi-E module

3.2 Control panel

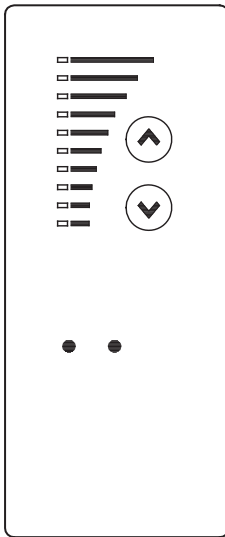

Fig. 12 CRE and TPE, TPED

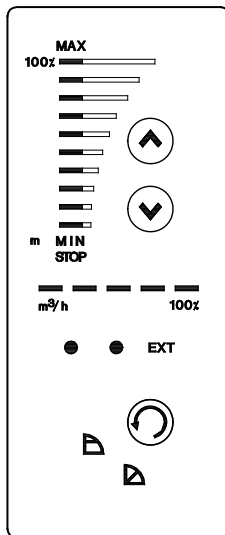







Fig. 13 TPE, TPED Series 2000



3.2.1 Operation

The motor control panel has the following buttons and indicator lights:

- Buttons  and  for setting of setpoint.
- Light fields, yellow, for indication of setpoint.
- Indicator lights, green (operation) and red (fault).

Switch control mode by pressing  in this sequence:

- constant pressure, .
- proportional pressure, .

Set the pump head by pressing  or .

The light fields of the control panel will indicate the set head (setpoint).

3.3 Indicator lights

3.3.1 Indicator lights on the control panel

The indicator lights on the control panel show the MGE-F motor's operating and alarm condition.

See section 4.5 *Fault finding using the indicator lights on the control panel* to get an overview of the meaning of the indicator lights.

3.4 Setting using the R100 remote control

The Grundfos R100 remote control is designed for wireless (IR) communication with the Grundfos E-products, including the MGE-F.

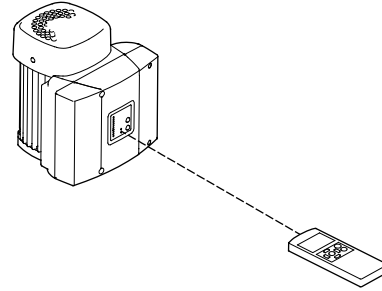

Fig. 14 The R100 communicates with the motor via infrared light

During communication, the R100 must be pointed at the control panel. When the R100 communicates with the motor, the red indicator light will flash rapidly. Keep pointing the R100 towards the control panel until the red indicator light stops flashing.

The R100 gives access to settings and status displays for the motor.

The displays are divided into four parallel menus. See fig. 15:

0. **GENERAL** (see operating instructions for the R100)

1. **OPERATION**

2. **STATUS**

3. **INSTALLATION.**

TM02 8513 0304

TM02 0936 0501

TM03 0126 4104

3.5 R100 menu structure

Figure 15 shows an overview of all the R100 displays available for the MGE-F.



The R100 menus adapt to the application set and possible functional modules.
 The menu structure below applies to a CRE pump.
 To see the correct menu structure, see the installation and operating instructions for the pump on which the MGE-F motor is mounted.

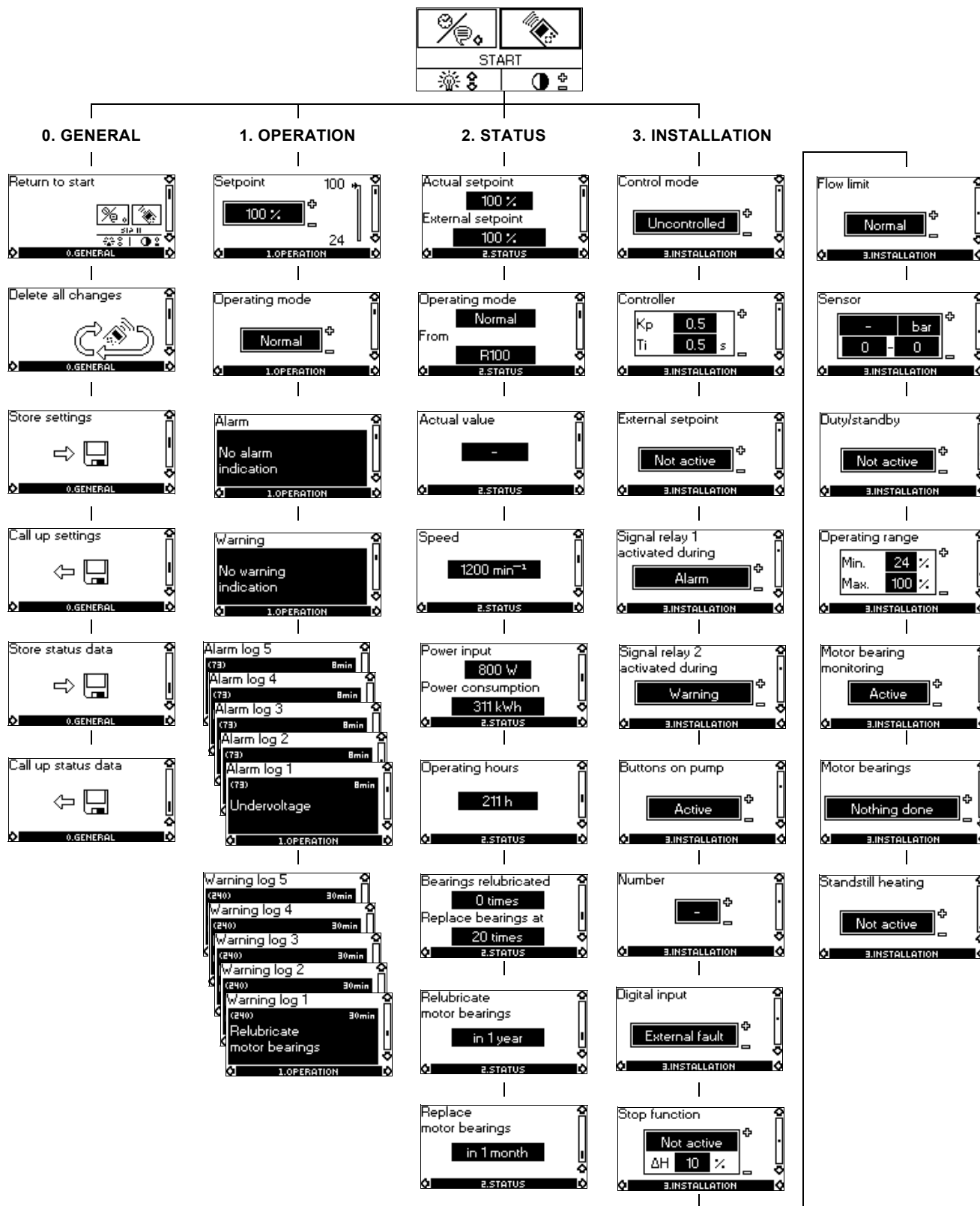
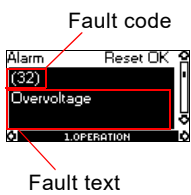

Fig. 15 R100 menu structure (for CRE pump)

3.6 Alarms and warnings

An alarm or a warning is indicated by a red indicator light on the control panel. The alarm and warning indication can be read with the R100.



Actual alarm and warning

Alarms and warnings are shown at the bottom of the **OPERATION** menu.

The first line shows the fault code. See section 4.6.1 *Alarm and warning list*.

The second line shows the fault text.

Reset the alarm or warning by pressing [OK].

If there are no alarms or warnings, the display will show "No alarm indication" or "No warning indication".

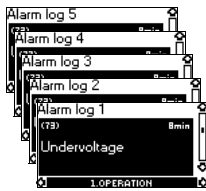

Alarm and warning logs

In case of alarm or warning, the latest five alarms and warnings appear from the alarm and warning logs.

"Alarm log 1" and "Warning log 1" show the latest alarm and warning, respectively.

"Alarm log 2" and "Warning log 2" show the latest alarm and warning but one, respectively, etc.

The display shows the logged alarm or warning with fault code and fault text.

The top right corner shows how long ago the alarm or warning occurred.

If the log in question is empty, the display will show "No alarm indication" or "No warning indication".

3.7 Alarm overview

In section 4.6.1 *Alarm and warning list*, you will find an overview of the MGE-F alarms and warnings.

4. Fault finding

4.1 Safety instructions

WARNING

Electric shock

Death or serious personal injury

- Due to the capacitors of MGE-F, touching live electrical parts may be fatal, even after the mains supply has been disconnected. Disconnect the mains supply to the motor has been disconnected and wait at least 30 minutes or the amount of time stated on the warning label under the terminal box cover before touching any live parts.
- Note that the relay may be connected to an external power supply and still be live after the mains supply to the motor has been disconnected.
- Installation, commissioning, service, and maintenance of equipment, systems, and circuits may only be performed by Grundfos service technicians or a Grundfos Authorised Service Partner (ASP) who have attended training equivalent to Grundfos Electronics Service Expert (GESE) or similar.
- Always observe local applicable safety regulation.



CAUTION

Hot surface

Minor or moderate personal injury

- MGE-F may be hot.



4.2 Fault finding procedure

Fault finding is based on these sections in this order:

- 4.2.1 *Operating conditions*
- 4.4 *Fault observations*
- 4.5 *Fault finding using the indicator lights on the control panel*
- 4.6 *Fault finding using alarm and warning codes*
- 7. *Tightening torques and lubrication.*

The necessary tools for the fault finding can be seen in section 8. *Service tools.*

4.2.1 Operating conditions

Correct functioning of the MGE-F depends on these points:

Mains supply

- Check nameplate data, and measure the actual supply voltage with a digital voltmeter (true RMS).
- Check the earth leakage circuit breaker and the backup fuses. The MGE-F has no internal fuses.

Pump and motor load

- Check nameplate data, and measure the actual current consumption with a digital amperemeter (true RMS). Do the pump and the MGE-F match?

External signals, for instance from another controller

- Check that the external signals are suitable for the MGE-F. See section 3.1 *Wiring diagrams and signal terminals* and installation and operating instructions for MGE 160 and MGE 180.
- Check that terminals 2 and 3 are connected and that the MGE-F has been started via the control panel.

Sensors connected

- Check that the sensor measuring range matches the pump application.
- Check that the settings of the MGE-F match the sensors (current, voltage, minimum and maximum values) (requires an R100).

Condensation

- Check whether condensation occurs in the terminal box. This may happen if the ambient temperature becomes very low. The problem may be overcome by enabling the standstill heating function and by removing the drain plug in the motor. See installation and operating instructions for MGE 160 and MGE 180.

Electromagnetic disturbances

- Check that the wiring complies with the EMC Directive. See installation and operating instructions for MGE 160 and MGE 180.

Start-up, installation and operating settings via the control panel or the R100

- Check that the green indicator light on the control panel (or inside the terminal box) is on.
- Check that the settings in the **INSTALLATION** menu match the pump application (requires an R100). The menu displays are described in detail in the installation and operating instructions for MGE 160 and MGE 180.

If the above points are according to the installation and operating instructions for MGE 160 and MGE 180 and the pump application, but a fault still exists and the red indicator light is on, continue the fault finding in sections 4.5 *Fault finding using the indicator lights on the control panel* and 4.6 *Fault finding using alarm and warning codes.*

4.3 PC Tool E-products as service tool

WARNING

Electric shock



Death or serious personal injury

- When making the wiring connections for PC-Tool Link, make sure that the power is switched off and wait 30 minutes. Connect the cable through the cable glands, and mount the cover before switching on the power.

PC Tool E-products is a software tool which enables communication with GENibus products from a PC using Microsoft Windows. PC Tool E-products can be used for fault correction of E-products, including the MGE-F.

4.3.1 Acquisition of PC Tool E-products

PC Tool E-products can be acquired via the Grundfos GTI database.

4.3.2 Connecting the PC Tool Link to the MGE-F

PC Tool Link is used for the physical connection between the PC and the MGE-F. PC Tool Link converts RS-485 used by the MGE-F to USB used by the PC. PC Tool Link also provides galvanic separation between the MGE-F and the PC.



Fig. 16 Example of connection of a PC to the MGE-F

4.4 Fault observations

4.4.1 Condensation in the terminal box

Description	Condensation in the terminal box.
Explanation	During standstill, the motor temperature will fall below the dew point of the surrounding air. Then the humidity in the air may condensate and settle on the surface of the terminal box.
Check/remedy	Activate <i>Standstill heating</i> with the R100 in the INSTALLATION menu.



4.5 Fault finding using the indicator lights on the control panel



The operational state of the motor incl. possible faults can be read via the indicator lights on the control panel. If an R100 remote control is available, we recommend you to start fault finding via the R100 fault code. See section 4.6 *Fault finding using alarm and warning codes*.



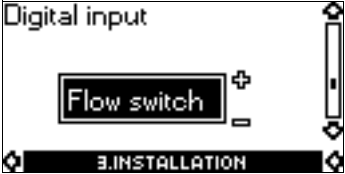

In case of certain faults in the electronics, the indicator lights on the control panel may indicate differently from the indicator lights on the control board. In these cases, the indicator lights on the control board indicate the current operating and alarm condition.

Indicator lights		Condition/cause	Remedy
Green	Red		
On	On	<p>Normal operation + indication of previous fault</p> <p>1. The pump is running at normal performance. – The pump's duty/standby function has been activated, but there is no communication with the standby pump.</p>	<p>a) Has the power supply to the standby pump been switched off? YES: Re-establish the power supply. NO: Proceed to point b).</p> <p>b) Has the communication cable been disconnected? YES: Check the communication cable. NO: Contact Grundfos Service.</p>
		<p>2. The pump is running at maximum speed. – The sensor signal is outside the set signal range.</p>	<p>a) Does the sensor setting correspond to the sensor type installed? (0-10 V, 0-20 mA, 4-20 mA)</p> <div style="text-align: center;"> </div> <p>NO: Correct the setting using the R100. YES: Proceed to point b).</p> <p>b) Is the sensor signal – below 10 V (type 0-10 V sensor)? – below 20 mA (type 0-20 mA sensor)? – between 4 and 20 mA (type 4-20 mA sensor)?</p> <div style="text-align: center;"> </div> <div style="text-align: center;"> </div> <p>NO: Replace the sensor. YES: Proceed to point d).</p> <p>c) Has the sensor been connected correctly, and does the sensor signal correspond to the system pressure? NO: Connect the sensor signal correctly. YES: Replace the I/O module or the terminal box. If the sensor is defective, replace it.</p>

[To be continued on the next page]

Indicator lights		Condition/cause	Remedy
Green	Red		
On	On	<p>3. The pump is running at minimum speed.</p> <ul style="list-style-type: none"> – The setpoint signal is outside the set signal range. 	<p>a) Set the pump to "open loop" operation, and connect 10 V supply to the setpoint input.</p> <p>Does the pump switch to maximum speed?</p> <p>NO: Proceed to point b). YES: The pump is OK.</p> <p>b) Does the setpoint setting correspond to the setpoint type installed? (0-10 V, 0-20 mA, 4-20 mA)</p>  <p>NO: Correct the setting using the R100. YES: Proceed to point c).</p> <p>c) Is the setpoint signal</p> <ul style="list-style-type: none"> – below 10 V (type 0-10 V sensor)? – below 20 mA (type 0-20 mA sensor)? – between 4 and 20 mA (type 4-20 mA sensor)? <p>Check for fault in the external setpoint signal.</p> <p>NO: Re-establish the correct setpoint signal, if necessary. YES: If the pump still does not run correctly, replace the terminal box.</p>
On	Off	<p>Normal operation</p> <p>1. The pump is running.</p> <ul style="list-style-type: none"> – Normal operational state. <p>2. The pump is not running.</p> <p>Operational stop which may be caused by</p> <ul style="list-style-type: none"> – the flow switch connected – the pump stop function. 	<p>a) The flow switch is closed.</p>  <p>The connection of a flow switch depends on the MGE functional modules. See the wiring diagrams in figs 8 to 11.</p> <p>Does the pump start when the connection between the flow switch terminals is cut?</p> <p>NO: Replace the I/O module. YES: The digital input is OK. The flow switch is defective. Replace it.</p> <p>b) The stop function has stopped the pump.</p>  <p>Does the pump start when you increase the flow and/or reduce the pressure in the system?</p> <p>NO: If the sensor is OK, replace the terminal box. YES: The input is OK.</p>

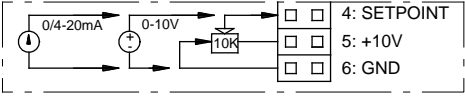
[To be continued on the next page]

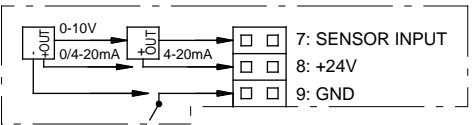
Indicator lights		Condition/cause	Remedy
Green	Red		
On	Off	<p>3. The pump is running at unexpectedly high or low speed.</p> <p>– Can be caused by fault in installation, setting or signal from setpoint/sensor or that the sensor input has been set to "active".</p>	<p>a) Has the correct setpoint type been set in the motor? (0-10 V, 0-20 mA, 4-20 mA)</p>  <p>NO: Correct the setting using the R100. YES: Proceed to point b).</p> <p>b) Has the external setpoint signal from potentiometer or external controller been connected correctly?</p>  <p>NO: Connect the setpoint signal correctly. YES: Proceed to point c).</p> <p>c) Has the correct sensor type been set in the motor? (0-10 V, 0-20 mA, 4-20 mA)</p>  <p>NO: Correct the setting using the R100. YES: Proceed to point d).</p> <p>d) Has the sensor been connected correctly, and does the sensor signal correspond to the system pressure?</p>  <p>NO: Connect the sensor signal correctly. YES: If the pump does not run correctly, replace the I/O module or the terminal box. If the sensor is defective, replace it.</p>
		Off	Off

TM02 1606 1601

TM04 2072 1908 TM02 1604 0601

[To be continued on the next page]

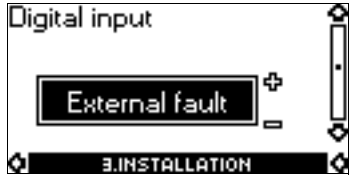
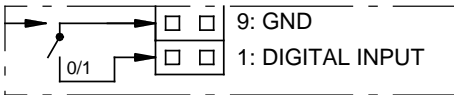
Indicator lights		Condition/cause	Remedy
Green	Red		
Off	On	<p>The pump has stopped due to a fault</p> <p>The pump has been stopped due to one of the following causes:</p>	See the fault indication on the R100 or PC Tool E-products.
		1. The pump is blocked or overloaded.	Remove the blockage, or reduce the load.
		2. The ambient temperature is too high, or the cooling is insufficient.	Re-establish sufficient cooling.
		3. Power supply fault: <ul style="list-style-type: none"> – undervoltage – overvoltage – phase failure – mains supply failure. 	Check that the supply voltage at the source is within the stated voltage range. If not, re-establish correct power supply.
		4. External fault.	<p>a) Has the R100 been set to external fault?</p> <div style="text-align: center;">  </div> <p>NO: Correct the setting using the R100. YES: Proceed to point b).</p> <p>b) Check the external contactor for continuity when closed across terminals 1-9.</p> <div style="text-align: center;">  </div> <p>NO: Contact between terminals 1 and 9 is closed. Seek the cause of fault in external signal transmitter. YES: Contact between terminals 1 and 9 is open. The E-pump is OK. Proceed to the next fault possibility.</p>
5. Other faults: <ul style="list-style-type: none"> – wrong terminal box – wrong configuration – fatal fault. 	<ul style="list-style-type: none"> • Replace the terminal box. • Reconfigure the terminal box. • Replace the terminal box. 		
Flashing, 1 Hz	Off	<p>Normal operational stop</p> <p>The pump has been stopped</p> <ul style="list-style-type: none"> • with the ☑ button • with the R100 • using the Grundfos GENIbus • by the motor start/stop function. (Input on terminal 2-3 is open). 	
Flashing, 1 Hz	On	<p>Normal operational stop + indication of previous fault</p> <p>The pump has been stopped</p> <ul style="list-style-type: none"> • with the ☑ button • with the R100 • using the Grundfos GENIbus • by the motor start/stop function, but was previously stopped due to a fault which has now disappeared. 	
Flashing, 5 Hz	On	<p>The pump has been stopped due to a fault in the product</p> <p>Pump is not running and</p> <ul style="list-style-type: none"> • communication with the R100 is not possible. • no reaction when you press ☑ or Ⓜ. • fatal internal communication fault in the pump. 	<p>Try resetting the fault by</p> <ul style="list-style-type: none"> • disconnecting the power supply. • waiting until all diodes are off. • re-establishing the power supply. <p>If this does not remedy the fault, the terminal box is defective. Replace the terminal box.</p>

TM02 1605 0601

4.6 Fault finding using alarm and warning codes

Apart from being indicated by the indicator lights on the control panel, alarms, warnings and their fault codes can be read using the R100.

4.6.1 Alarm and warning list

The list below gives you an overview of the possible alarms and warnings and a description of their causes and suggestions for remedy.

These abbreviations are used in the column "Fault type":

W: Warning.

A: Alarm.

1): The alarm can be configured to Warn/Max/Min/Stop/User using the PC Tool E-products.

Fault code	Fault reading in the R100	Fault reading in PC Tool E-products	Fault type
Explanation/cause		Remedy	
3	External fault	External fault signal	A
The digital input set for "External fault" was or is closed (terminal 1, 10 or 11).		When the digital input is no longer closed, the fault indication can be reset either with the R100 or by pressing ☺ or ☹.	
4	Too many restarts	Too many restarts (from standby mode per 24)	A
<ul style="list-style-type: none"> The number of attempted restarts at 10-second intervals after a fault has exceeded four within one minute. The number of attempted restarts at five-minute intervals after a fault has exceeded 16 within 24 hours. 		Seek the cause under the fault log code numbers in the R100. The pump will automatically attempt to restart after 24 hours. The fault indication can be reset either with the R100 or by pressing ☺ or ☹.	
30	Replace motor bearings	Motor bearings need change (service information)	W
The motor has reached the number of operating hours for the bearing service life that is stated in the configuration.		Replace the bearings. See section 5.2 <i>Replacement of motor bearings</i> .	
31	Replace varistor	Motor varistor(s) need change (service information)	W
The varistor has been exposed to the allowable number of transients and needs replacing.		Contact Grundfos Service.	
32	Overvoltage	Overvoltage	A
The supply voltage has been or is too high.		Reduce the voltage to the specified level (see the nameplate).	
40	Undervoltage	Undervoltage	A
The supply voltage has been or is too low.		Increase the voltage to the specified level (see the nameplate).	
41	Undervoltage	Undervoltage transient	A
There has been a voltage drop in the supply voltage caused by one of the following: <ul style="list-style-type: none"> Supply cable too small. Another big user is supplied from the same panel. 			
45	Mains voltage asymmetry	Voltage asymmetry	A
The supply voltage has been or is asymmetric.		Check the supply voltage at the source while the motor is loaded.	
49	Overload	Overcurrent (i_line, i_dc, i_mo)	A
The terminal box or the motor is heavily overloaded. Cause: <ul style="list-style-type: none"> Blocked pump. Blocked rotor. Continued overload. Incorrect configuration of the terminal box. Wrong terminal box. Fault in stator windings. Power supply failure (phase failure). 		<ul style="list-style-type: none"> Remove the blockage. Remove the blockage. Reduce the load. Contact Grundfos Service. Contact Grundfos Service. Contact Grundfos Service. Re-establish correct power supply. 	
51	Overload	Blocked motor/pump	A
The pump is blocked during start-up which causes a heavy overload. The input current is very high; the motor P > 120 % for 60 seconds.		Remove the blockage.	

Fault code	Fault reading in the R100	Fault reading in PC Tool E-products	Fault type
Explanation/cause		Remedy	
55	Overload	Motor current protection activated (MCP)	A
<p>The built-in motor-current protection function has registered a continued overload of more than 125 % of rated current for 60 seconds.</p> <p>Cause:</p> <ul style="list-style-type: none"> Continued overload. Incorrect configuration of the terminal box. Fault in stator windings. 		<ul style="list-style-type: none"> Reduce the load by limiting the pump flow. Contact Grundfos Service. Contact Grundfos Service. 	
56	Underload	Underload	A
<p>The motor is underloaded.</p> <p>Cause:</p> <ul style="list-style-type: none"> Incorrect configuration of the terminal box. The pump has run dry. 		<ul style="list-style-type: none"> Check the settings of the terminal box. Make sure that all valves in the piping system are open and that there is water in the piping system. 	
57	Dry running	Dry running	A
<p>The pump has run dry.</p>		<p>Make sure that all valves in the piping system are open and that there is water in the piping system.</p>	
65	Too high motor temperature	Motor temperature	A
<p>The temperature sensor in the motor has measured a too high winding temperature.</p> <p>Cause:</p> <ul style="list-style-type: none"> Dust and dirt in the cooling fins. Too high ambient temperature. Fault in stator windings. 		<ul style="list-style-type: none"> Clean the cooling fins. Improve the cooling. Contact Grundfos Service. 	
73	Undervoltage	Hardware shutdown (HSD)	A
<p>The current limit of the electronic module has been exceeded.</p> <p>Cause:</p> <ul style="list-style-type: none"> Incorrect configuration of the terminal box. Fault in stator windings. Terminal box defective. 		<ul style="list-style-type: none"> Contact Grundfos Service. Contact Grundfos Service. Contact Grundfos Service. 	
77	Duty/standby, Communication fault	Twin pump communication fault	W
<p>Communication between the two pumps which have been set to duty/standby function has been interrupted.</p> <p>Cause:</p> <ul style="list-style-type: none"> Power supply to standby pump has been cut. Communication cable has been cut. Communication module defective. 		<ul style="list-style-type: none"> Re-establish the power supply. Check the communication cable. Replace communication module. 	
85	Other fault	Freq. converter parameter verification error (EEPROM)	A
<p>The EEPROM has lost its contents.</p>		<p>Contact Grundfos Service.</p>	
88	Sensor 1 signal outside signal range	General sensor signal fault / feedback sensor signal fault	1)
<p>Sensor signal type 4-20 mA: signal below 2 mA or above 22 mA.</p> <p>Sensor signal type 0-20 mA: signal above 22 mA.</p> <p>Sensor signal type 0-10 V: signal above 11 V.</p> <ul style="list-style-type: none"> Signal range set incorrectly. Sensor incorrectly connected. Sensor defective. Sensor cable defective. Incorrect power supply to sensor. 		<ul style="list-style-type: none"> Correct the signal range setting. Connect the sensor correctly. Replace the sensor. Check the sensor cable. Replace the functional module. 	
91	Temperature sensor 1 signal outside signal range	Temperature sensor 1 signal fault	1)
<p>The sensor signal has been short-circuited or cut.</p>		<p>Replace the temperature sensor.</p> <p>Before doing any work, turn off the mains switch or power off.</p>	

Fault code	Fault reading in the R100	Fault reading in PC Tool E-products	Fault type
Explanation/cause		Remedy	
93	Sensor 2 signal outside signal range	Sensor 2 signal fault	1)
Same as fault 88.		Same as fault 88.	
96	Setpoint signal outside signal range	Reference input signal fault	1)
<p>Sensor signal type 4-20 mA: signal below 2 mA or above 22 mA. Sensor signal type 0-20 mA: signal above 22 mA. Sensor signal type 0-10 V: signal above 11 V.</p> <ul style="list-style-type: none"> • Signal range set incorrectly. • Setpoint signal incorrectly connected. • Incorrect supply voltage to the setpoint. 		<ul style="list-style-type: none"> • Correct the signal range setting. • Connect the setpoint signal correctly. • Replace the functional module. 	
105	Overload	Electronic rectifier protection activated (ERP)	A
<p>The electronic module/motor is heavily overloaded, and the temperature of the electronics is above 100 °C. The measured temperature can be read via PC Tool E-products. Cause:</p> <ul style="list-style-type: none"> • Temperature sensor defective. • Continued overload. • The ambient temperature is too high, or the cooling is insufficient. • Incorrect configuration of the terminal box. 		<ul style="list-style-type: none"> • Contact Grundfos Service. • Reduce the load. • Improve the cooling. • Contact Grundfos Service. 	
106	Overload	Electronic inverter protection activated (EIP)	A
<p>The electronic module/motor is heavily overloaded, and the temperature of the electronics is above 100 °C. The measured temperature can be read via PC Tool E-products. Cause:</p> <ul style="list-style-type: none"> • Temperature sensor defective. • Continued overload. • The ambient temperature is too high, or the cooling is insufficient. • Incorrect configuration of the terminal box. 		<ul style="list-style-type: none"> • Contact Grundfos Service. • Reduce the load. • Improve the cooling. • Contact Grundfos Service. 	
148	DE bearing temperature high	Motor drive-end (DE) bearing temp. warning limit Motor drive-end (DE) bearing temp. alarm limit	W A
<p>The drive-end motor bearing has become too hot. Cause:</p> <ul style="list-style-type: none"> • The bearing is worn. • The motor is dirty. 		<ul style="list-style-type: none"> • Replace the bearing. See section 5.2 <i>Replacement of motor bearings</i>. • Check and clean, if necessary, <ul style="list-style-type: none"> – the fan – the motor cooling fins. 	
149	NDE bearing temperature high	Motor non-drive-end (NDE) bearing temp. warning limit Motor non-drive-end (NDE) bearing temp. alarm limit	W A
<p>The non-drive-end motor bearing has become too hot. Cause:</p> <ul style="list-style-type: none"> • The bearing is worn. • The motor is dirty. 		<ul style="list-style-type: none"> • Replace the bearing. See section 5.2 <i>Replacement of motor bearings</i>. • Check and clean, if necessary, <ul style="list-style-type: none"> – the fan – the motor cooling fins. 	
155	Undervoltage	Inrush fault	A
<p>The terminal box voltage is outside the alarm limit. Cause:</p> <ul style="list-style-type: none"> • Fault in the voltage supply. • Transients in the voltage supply during operation. 		<ul style="list-style-type: none"> • Re-establish the voltage supply. • Contact Grundfos Service. 	

Fault code	Fault reading in the R100	Fault reading in PC Tool E-products	Fault type
Explanation/cause		Remedy	
156	Other fault	Internal communication failure in frequency converter	A
Internal communication fault in the pump due to defect in the terminal box.		Contact Grundfos Service.	
175	Temperature sensor 2 signal outside signal range	Temperature sensor 2 signal fault	1)
Same as fault 91.		Same as fault 91.	
190	Limit 1 exceeded	Limit 1 exceeded	1)
191	Limit 2 exceeded	Limit 2 exceeded	
<p>This is a monitoring function offering information, alarm or warning if a low or high limit is exceeded. The function can only be set with the PC Tool E-products.</p> <p>The limit set has been exceeded either upwards or downwards.</p>		<p>The function can be set to monitor</p> <ul style="list-style-type: none"> • sensor 1 or 2 • Pt100 sensor 1 or 2 • external setpoint • the feedback signal. <p>Procedure:</p> <ol style="list-style-type: none"> 1. Using PC Tool E-products, check which function is being monitored. 2. Check in the pump system whether the alarm or warning is real. If it is real, remedy the fault. 3. If the alarm or warning seems to be wrong for the pump system, troubleshoot according to the selected sensor using these service instructions. 	
240	Relubricate motor bearings	Motor bearings need lubrication (service information)	W
The motor has reached the number of operating hours stated in the configuration for the bearing lubrication.		Lubricate the bearings. See section 5.1 <i>Lubrication of motor bearings</i> .	

5. Maintenance

WARNING

Electric shock

Death or serious personal injury

- Installation, commissioning, service, and maintenance of equipment, systems, and circuits may only be performed by Grundfos service technicians or a Grundfos Authorised Service Partner (ASP) who have attended training equivalent to Grundfos Electronics Service Expert (GESE) or similar.
- Always observe local applicable safety regulation.



Follow these instructions when it is necessary to maintain the motor or the terminal box.

Position numbers of components (numbers in brackets) refer to section 6. *Drawings and diagrams*.

Position letters of tools (letters in brackets) refer to section 8. *Service tools*.

Prior to dismantling

Disconnect the mains supply in accordance with local regulations.

WARNING

Electric shock

Death or serious personal injury

- Due to the capacitors of MGE-F, touching live electrical parts may be fatal, even after the mains supply has been disconnected. Disconnect the mains supply, and wait at least 30 minutes or the amount of time stated on the warning label under the terminal box cover before touching any live parts.
- Note that the relay may be connected to an external power supply and still be live after the mains supply to the motor has been disconnected.



CAUTION

Hot surface

Minor or moderate personal injury

- MGE-F may be hot.



During assembly

Tighten screws and nuts to the correct torque. See section 7.1 *Tightening torques*.

5.1 Lubrication of motor bearings

5.1.1 Grease and lubrication intervals

The recommended grease type and quantity and the recommended lubrication intervals in hours appear from the lubricating plate fitted to the motor. When the MGE-F has reached the prescribed number of operating hours, it will give a lubrication warning (fig. 17) that will appear on the R100 or PC Tool E-products. See section 3.6 *Alarms and warnings*.

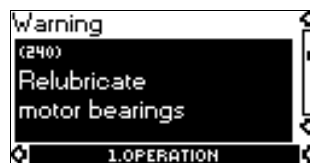

Fig. 17 Bearings need to be lubricated

5.1.2 Lubrication procedure



The motor must be running during the lubrication. This ensures that the new grease is distributed evenly and that the old grease is pressed out of the bearing.

Connect the grease gun to the lubricating nipples, and apply the prescribed quantity of grease.

Confirm the lubrication in the **INSTALLATION** menu of the R100. See fig. 18. Confirmation can also be made via PC Tool E-products.

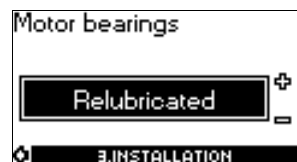

Fig. 18 Confirmation of bearing lubrication

5.2 Replacement of motor bearings

When the MGE-F has reached the prescribed number of operating hours, it will give a warning about replacement of bearings (fig. 19) that will appear on the R100 or PC Tool E-products. See section 3.6 *Alarms and warnings*.

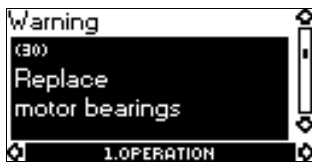

Fig. 19 Bearings need to be replaced

5.2.1 Removing the bearings

1. Remove the screws (pos. 152) holding the fan cover (pos. 151), and remove the fan cover.
2. Remove the retaining ring (pos. 156c) holding the fan (pos. 156).
3. Pull off the fan.
4. Remove the three screws (pos. 182a) holding the bearing cover (pos. 155d).
5. Remove the screws (pos. 185a) holding the bearing end shield in the non-drive end (pos. 156a).
6. Remove the bearing end shield in the non-drive end and the spring (pos. 158).
7. Remove the screws (pos. 185) holding the bearing end shield in the drive end (pos. 156b).
8. Carefully pull the bearing end shield in the drive end and the shaft/rotor (pos. 172) out of the stator housing. Take care not to damage the stator windings.
9. Remove the three screws (pos. 182) holding the bearing cover (pos. 155a).
10. Remove the bearing end shield in the drive end using a puller (pos. B).
11. Pull bearings (pos. 153 and 154) off the shaft using a puller. If the drive end bearing is stuck in the bearing end shield, heat up the bearing end shield, and press the bearing out by pushing it through the shaft hole.
12. Clean and check the bearing journals of the shaft and the bearing seats of the bearing end shields.

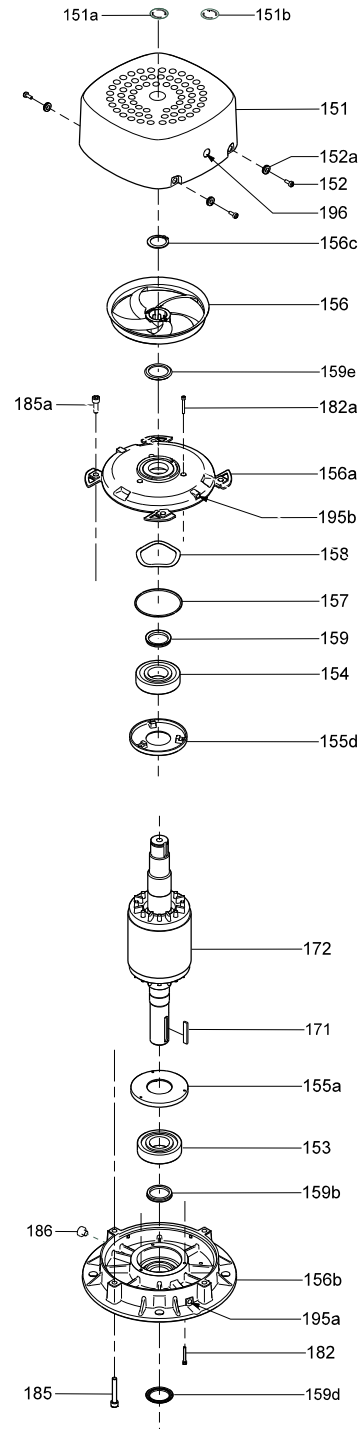

Fig. 20 Detail from fig. 29, exploded view of the MGE-F

5.2.2 Fitting the bearings

1. Fit bearing covers (pos. 155a and 155d) on the shaft (pos. 172).
2. Heat up the bearings (pos. 153 and 154) to 90 °C, and fit them on the shaft (pos. 172).
An induction heater is the most suitable heating method for greased-for-life bearings (2Z and 2RZ).
Note: Remember to demagnetise the components, if necessary.
Alternatively, heat up the components using a heating plate or an oil bath.
If it is not possible to heat up the bearings before fitting them, press or tap them into position by applying the force to the inner ring of the bearing.
3. Replace V-ring (pos. 159b) in the bearing seat of the bearing end shield in the drive end (pos. 156b).
4. Fit the bearing end shield in the drive end on the bearing. If necessary, heat up the bearing end shield to approx. 80 °C to ensure that the bearing seat is large enough for an easy and safe fitting of the bearing.
5. Fit the three screws (pos. 182) holding the bearing cover (pos. 155a), and **tighten them to 8 Nm**.
6. Carefully move the bearing end shield in the drive end and the shaft/rotor to their position inside the stator housing. Take care not to damage the stator windings.
7. Fasten the bearing end shield in the drive end with the screws (pos. 185), and **cross-tighten them to 27 Nm**.
8. Replace V-ring (pos. 159e) and O-ring (pos. 157) in the bearing seat of the bearing end shield in the non-drive end (pos. 156a).
9. Fit spring (pos. 158) in the bearing seat of the bearing end shield in the non-drive end.
10. Fit the three screws (pos. 182a) holding the bearing cover (pos. 155d), and **tighten them to 8 Nm**.
11. Fasten the bearing end shield in the non-drive end with the screws (pos. 185a), and **cross-tighten them to 27 Nm**.
12. Fit fan (pos. 156) and retaining ring (pos. 156c).
13. Fit fan cover (pos. 151), and fasten it with the screws (pos. 152) and the rubber bushes. **Tighten the screws to 10 Nm**.
14. If the bearings are not prelubricated, lubricate the bearings according to instructions. See section 7.2 *Lubricating intervals and grease*.
15. Confirm the replacement of the bearings in the **INSTALLATION** menu of the R100 (or via PC Tool E-products). See fig. 21.



Fig. 21 Confirmation of bearing lubrication

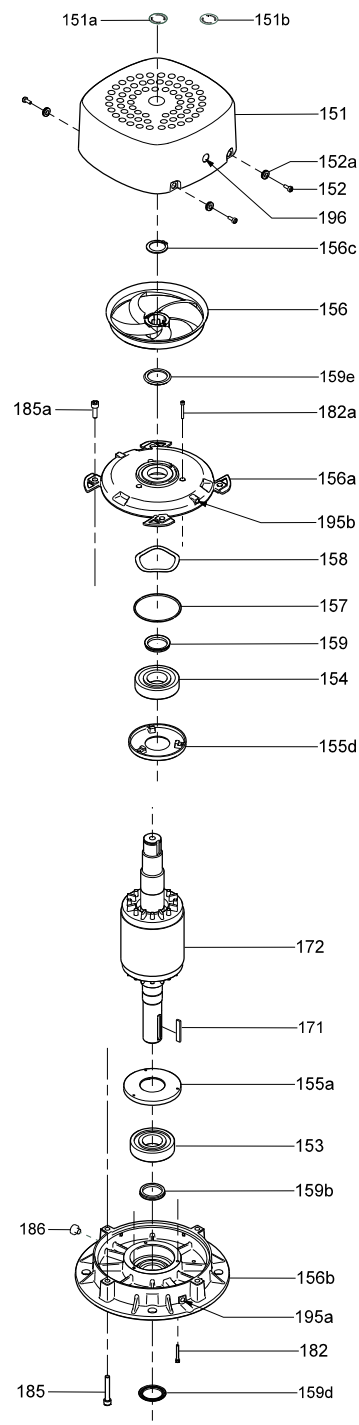

Fig. 22 Detail from fig. 29, exploded view of the MGE-F

6. Emergency operation (bypass)

If it is necessary to continue pump operation even if replacement or repair of the terminal box is not possible, establish emergency operation by connecting the motor direct to the mains supply.

WARNING

Electric shock

Death or serious personal injury

- Before starting any work on the product, make sure that the power supply is switched off and that it cannot be accidentally switched on.
- During emergency operation, the motor is only protected by its backup fuse. Normal operation must therefore be re-established as quickly as possible.
- Wait 30 minutes before doing any work inside the product.



Before establishing emergency operation of the pump, make sure that the motor is OK. You may for instance meg the motor.



The starting current will increase when the frequency converter is bypassed.

Emergency operation is illustrated on a label on the cover over the motor terminals. See fig. 25.

Prior to establishing emergency operation

Disconnect the mains supply in accordance with local regulations.

WARNING

Electric shock

Death or serious personal injury

- Due to the capacitors of MGE-F, touching live electrical parts may be fatal, even after the mains supply has been disconnected. Disconnect the mains supply, and wait at least 30 minutes or the amount of time stated on the warning label under the terminal box cover before touching any live parts.
- Note that the relay may be connected to an external power supply and still be live after the mains supply to the motor has been disconnected.



6.1 Establishing emergency operation

1. Loosen the four screws in the terminal box cover, and remove the cover from the terminal box.
2. Remove the three mains supply conductors from the supply terminals, but leave the protective earth conductor in the PE terminal. See fig. 23.
3. Remove the cover over the motor terminals. See fig. 24. Unscrew the nuts from the motor terminals.

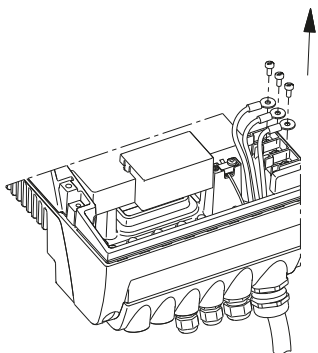

Fig. 23 Cover over the supply terminals

4. Connect the conductors as shown on the label on the cover over the motor terminals. See fig. 25. Use the screws from the supply terminals and the nuts from the motor terminals. See fig. 26.

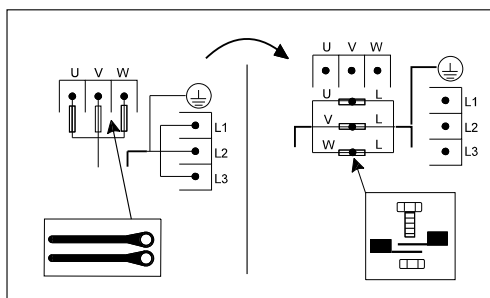

Fig. 25 Emergency label on the cover over the motor terminals

5. Pull the insulating hose around the motor conductors up over the joint. Wind insulating tape or similar around the ends of the insulating hose in order to fasten it over the joint. See figs. 27 and 28.

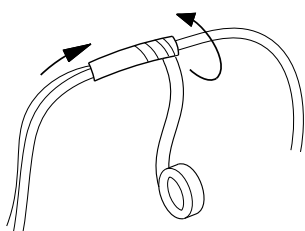

Fig. 27 Insulating the joint

6. Briefly start the motor, and observe the direction of rotation.



It is important to check (and change, if necessary) the motor's direction of rotation to ensure that the pump is not running backwards.

7. If the motor's direction of rotation is wrong, interchange two of the supply conductors (phases).
8. Put the terminal box cover (pos. 164) back on, and fasten it with the four screws (pos. 166).
Tighten the screws to 7 Nm.

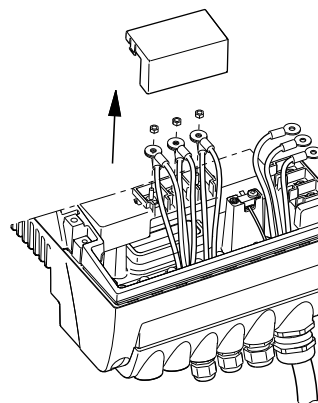

Fig. 24 Cover over the motor terminals

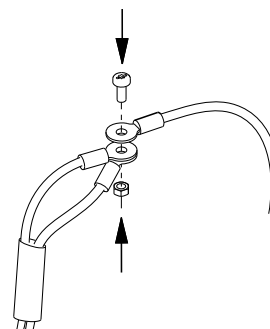

Fig. 26 Joining the motor conductors (two) and the supply conductor

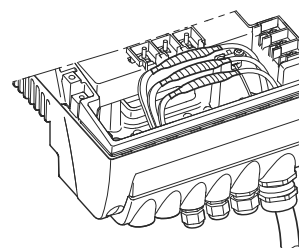

Fig. 28 The joints placed in the terminal box

6.2 Re-establishment of frequency converter operation

1. Loosen the four screws in the terminal box cover, and remove the cover from the terminal box.
2. Remove the insulating tape, and separate one of the joints of motor conductors and supply conductor. Push the insulating hose down over the motor conductors again.
3. Fit the motor conductors on the correct motor terminal: Blue/black to U1/W2, white/grey to V1/U2 and orange/yellow to W1/V2. **Tighten them to 2.2 Nm.**
4. Fit the supply conductor to one of the supply terminals, and **tighten it to 2.2 Nm.**
5. Repeat steps 2 to 4 for the remaining two joints.
6. Fit the cover over the motor terminals.
7. Fit the cover over the supply terminals (pos. 284), and **tighten the screw to 7 Nm.**
8. Put the terminal box cover (pos. 164) back on, and fasten it with the four screws (pos. 166). **Tighten the screws to 7 Nm.**

7. Drawings and diagrams

The position numbers in fig. 29 refer to the list on page 28.

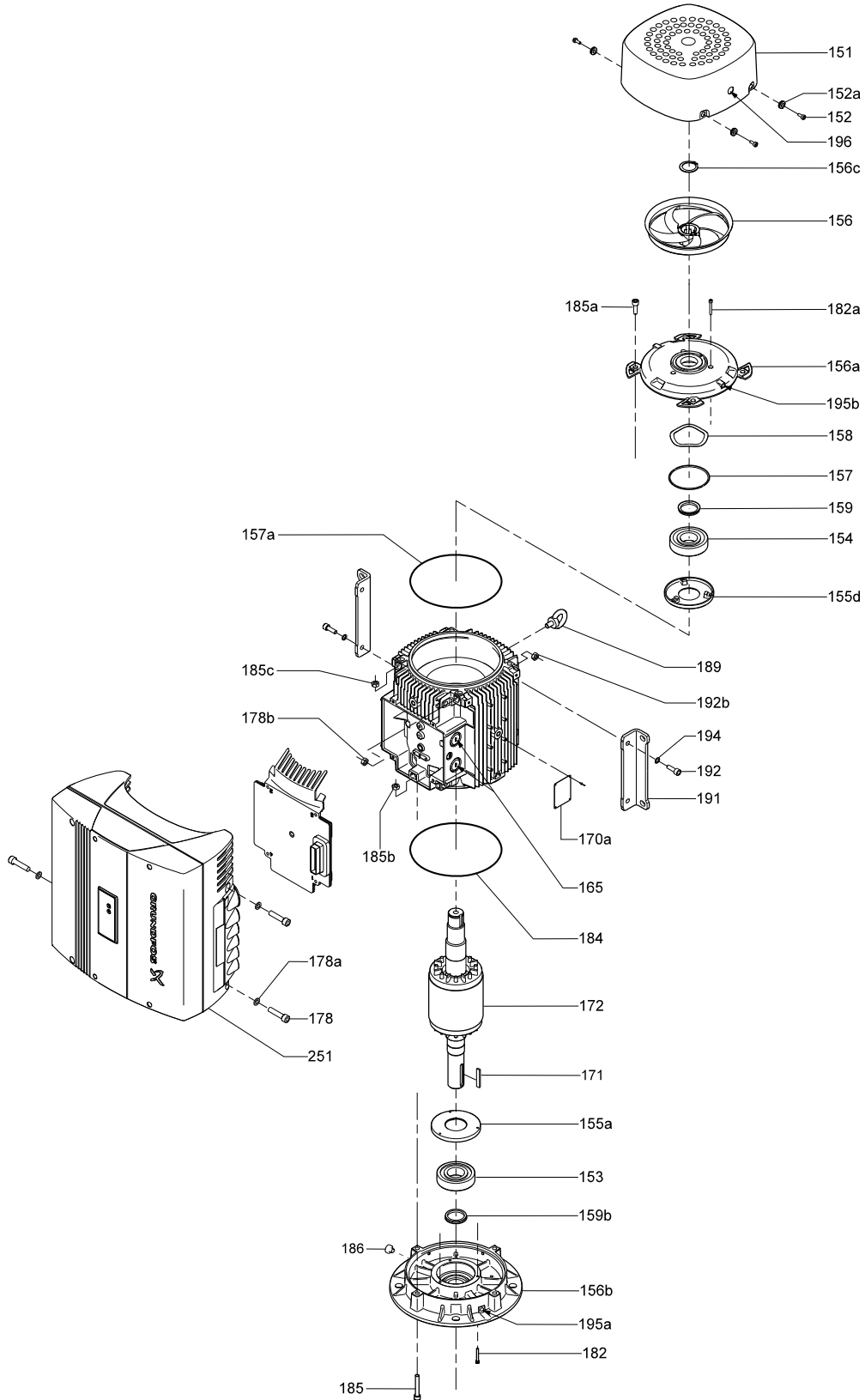
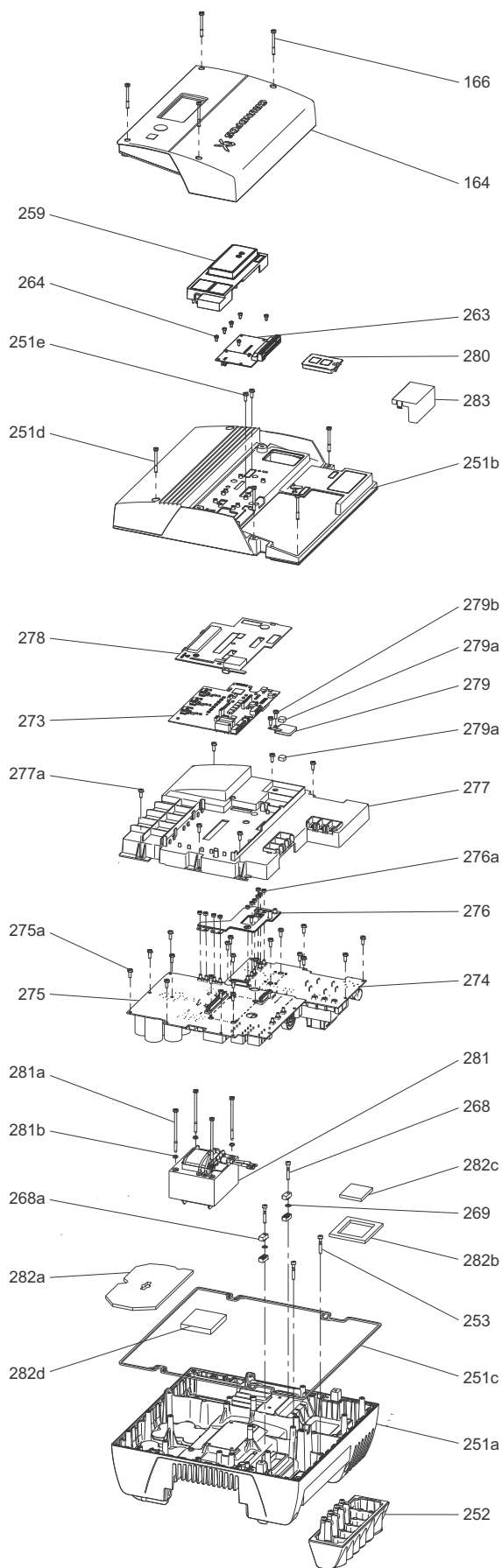

Fig. 29 Exploded view, MGE-F

Pos.	Description
151	Fan cover
152	Screw, fan cover
152a	Rubber bushing
153	Ball bearing, drive end
154	Ball bearing, non-drive end
155a	Inner bearing cover, drive end
155d	Inner bearing cover, non-drive end
156	Fan
156a	Bearing end shield, non-drive end
156b	Bearing end shield, drive end
156c	Circlip for fan
157	O-ring, bearing, non-drive end flange
157a	Gasket, non-drive end
158	Corrugated spring
159	V-ring, non-drive end
159b	V-ring, drive end
165	Knock-out cable entry
170a	Nameplate
171	Key
172	Shaft with rotor
178	Screw, terminal box
178a	Lock washer, D10.5/D16 x 1 A2
178b	Nut, M10 DIN 934 A2, waxed
182	Screw, bearing cover
182a	Screw, bearing cover, non-drive end
184	Gasket, drive end
185	Screw, drive end
185a	Screw, non-drive end
185b	Nut, drive end
185c	Nut, non-drive end
186	Plug for drain hole
189	Eyebolt
191	Foot
192	Screw for foot
192b	Nut for foot
194	Lock washer
195a	Lubricating nipple, drive end flange
195b	Lubricating nipple, non-drive end flange
196	Protective cover for lubricating nipple, non-drive end
251	Terminal box with integrated frequency converter



Pos.	Description
164	Terminal box cover
166	Screw for terminal box cover
251a	Terminal box, lower part
251b	Terminal box top
251c	Gasket for terminal box top
251d	Screw for terminal box top
251e	Screw for terminal box top
252	Cable entry block, complete
253	Screw for cable entry block,
259	Control panel
263	Functional module, complete with plugs
264	Screw, functional module
268	Earth screw
268a	Earth clamp
269	Washer, earth screw
273	Control board
274	Rectifier board
275	Inverter board
275a	Screw for inverter board and rectifier board
276	Busbar
276a	Nut for busbar
277	Insulation cover
277a	Screw for insulation cover
278	Cover over control board
279	Varistor
279a	Shock absorber for varistor
279b	Screw for varistor
280	Cover for varistor
281	DC choke
281a	Screw for DC choke
281b	Washer for DC choke
282a	Gap filler for inverter board
282b	Gap filler for RFI choke part 1
282c	Gap filler for RFI choke part 2
282d	Gap filler for DC choke
283	Cover over motor terminals

Fig. 30 Exploded view, terminal box

TM07 6726 2520

8. Tightening torques and lubrication

8.1 Tightening torques

Pos.	Description	Torque [Nm]
Terminal box		
166	Screws for terminal box cover	4
251d	Screws for terminal box top	4
251e	Screws for terminal box top	4
277a	Screws for cover	4
253	Screws for cable entry block	4
	Terminals for supply conductors	2.2
	Terminals for motor conductors	2.2
268	Terminal for PE conductor	4
279b	Terminal for varistor	1.5
276a	Nuts for busbar	2.2
281a	Screws for coil	4
275a	Screws for rectifier board and inverter board	4
	Screws for inverter and IGBT (step 1/step 2)	4 / 4
264	Screws for modules	2 - 2.5
Motor		
152	Screws for fan cover	8
178	Screws for terminal box	27
182	Screws for bearing cover in the drive end	
182a	Screws for bearing cover in the non-drive end	8
185	Screws for bearing end shield in the drive end	
185a	Screws for bearing end shield in the non-drive end	27

8.2 Lubricating intervals and grease

Lubricating intervals, grease quantity and type appear from the motor lubricating plate.

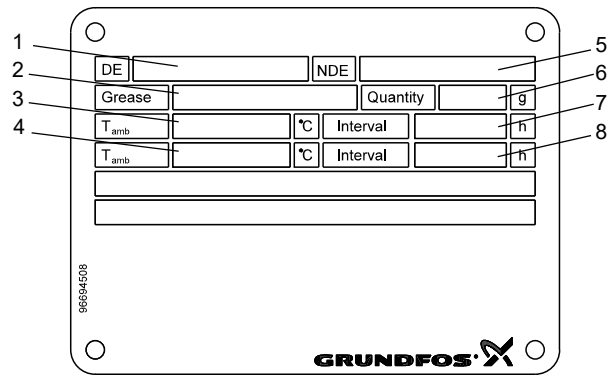
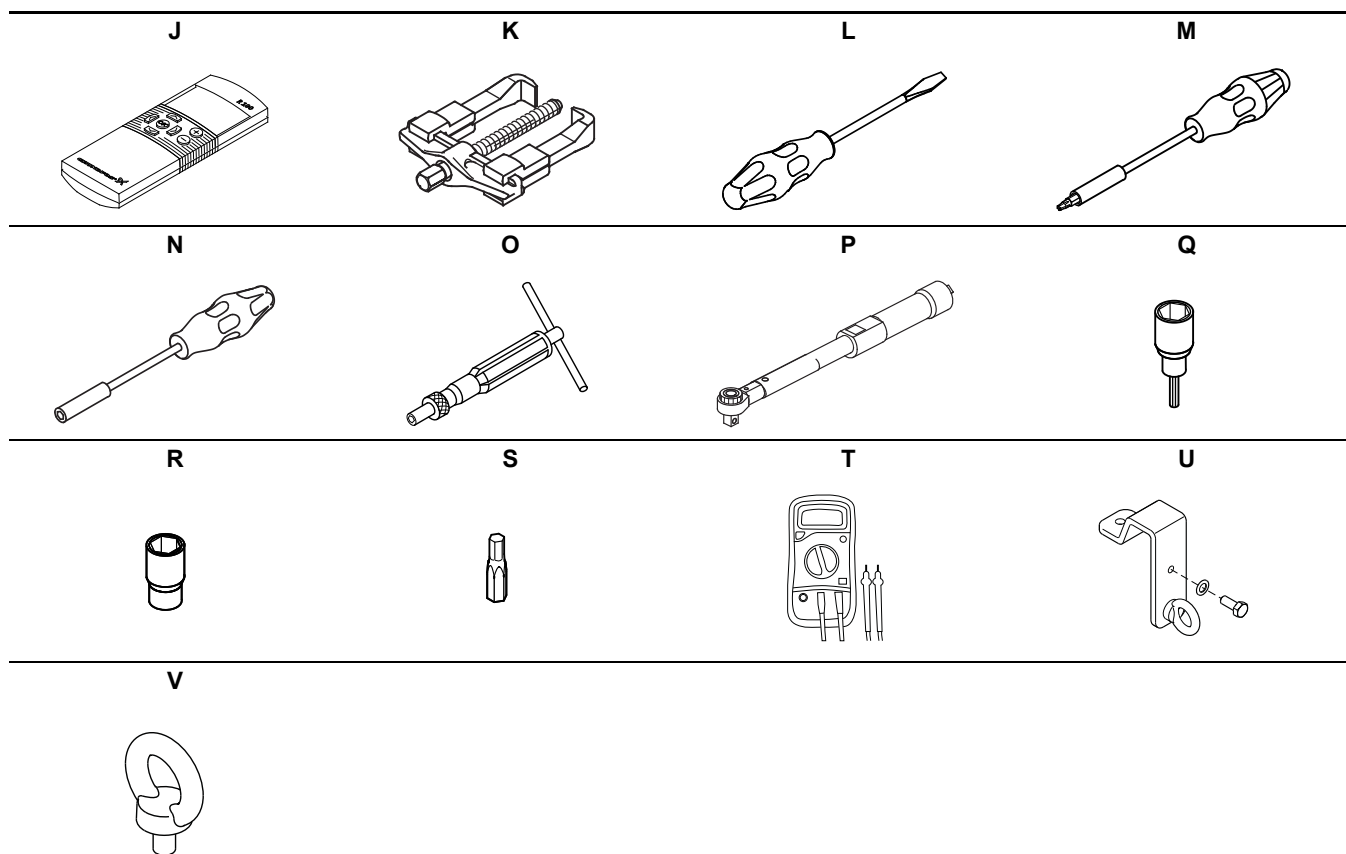

Fig. 31 Lubricating plate of MGE-F

Pos.	Description
1	Bearing, drive end
2	Grease type
3	Ambient temperature
4	Ambient temperature
5	Bearing, non-drive end
6	Quantity of grease
7	Lubricating interval
8	Lubricating interval

9. Service tools



Special tools

Pos.	Designation	Supplementary information	Product number
A	R100 PC Tool E-products		96615297 96562869

Standard tools

Pos.	Designation	Supplementary information	Product number
B	Puller		
C	Slotted screwdriver		
D	Torx® screwdrivers (set)	T20, T25	96884908
E	Hexagon socket screwdriver	8 mm	

Torque tools

Pos.	Designation	Supplementary information	Product number
F	Torque screwdriver	1-6 Nm	SV0438
G	Torque wrench		
H	Hexagon head driver		
I	Hexagon socket		
J	Torx® bits (set)	T20, T25	96884936

Measuring tools

Pos.	Designation	Supplementary information	Product number
K	Digital multimeter, type RMS with diode test function	CAT III / 1000 V	

Lifting equipment

Pos.	Designation	Supplementary information	Product number
L	Lifting bracket		
M	Eye bolt	M8	

96893745 06.2020

ECM: 1289263

Trademarks displayed in this material, including but not limited to Grundfos, the Grundfos logo and "be think innovate" are registered trademarks owned by The Grundfos Group. All rights reserved. © 2020 Grundfos Holding A/S. All rights reserved.